

UNCLASSIFIED
[REDACTED]

**AEROSPACE
LIBRARY**

Document No. A65-11232
Copy No. ARCHIVES



CLASSIFICATION CHANGED TO
[REDACTED]

By Authority of **UNCLASSIFIED**
ADG
By AOLIB/TR Date 6-26-70

CHANGE ALL MARKINGS
PRIOR TO CIRCULATION



AEROSPACE CORPORATION

PROPERTY OF
AEROSPACE CORPORATION
RETURN TO LIBRARY

UNCLASSIFIED
[REDACTED]

NRO APPROVED FOR
RELEASE 1 JULY 2015



Handwritten text on the right side of the page, including a date "JUL 1 1973" and a reference number "100-108888-10000".

UNCLASSIFIED

DOCUMENT CHANGE RECORD

Instructions:

- 1) This form will be inserted into a Secret document immediately behind the cover, or behind the title page if there is no cover, whenever any addition or change is made.
- 2) Record all additions or changes inserted into or attached to a document and the disposition of all pages made obsolete by such additions or changes.

Title of Basic Document: (U)An analysis of the requirements for very high accuracy image motion compensation. TOR-669(6107-40)-1. AGS-11232, c.1

Classified Document Control No. (CDCN): AS-65-0000-03578c c.32

INCORPORATED MATERIAL

CDCN & Copy No. of Incorporated Contents	Classification	Down-Grade Group	Orig. Date	Disposition of Remainder of Incorporated document (✓)			Disposition of Replaced Pages (✓)			Change made by (name)	Date of Change
				None	Retained	Destroy	None	Retained	Destroy		
AS-65-0000-04815, c.32 <i>(Errata pages)</i>	S	4	11-4-65		XX				X	AOLIB/elm.	12-10-65

NRO APPROVED FOR
RELEASE 1 JULY 2015

UNCLASSIFIED
CONFIDENTIAL

UNCLASSIFIED
[REDACTED]

Copy 32

AS-65-0000-03578
(for security control only)

A65-11232

*Includes docin
material - see
Secret doc. change record*

Report No. TOR-669(6107-40)-1

(U) AN ANALYSIS OF THE REQUIREMENTS FOR
VERY HIGH ACCURACY
IMAGE MOTION COMPENSATION

Prepared by

R. Grove, A. Mandl, and L. E. Watson
Optical and Electrical Department

El Segundo Technical Operations
AEROSPACE CORPORATION
El Segundo, California

Contract No. AF 04(695)-669

October 1965

Prepared for

COMMANDER SPACE SYSTEMS DIVISION
AIR FORCE SYSTEMS COMMAND
LOS ANGELES AIR FORCE STATION
Los Angeles, California

GROUP-4

Downgraded at 3-year intervals;
declassified after 12 years.

UNCLASSIFIED
[REDACTED]

UNCLASSIFIED

NRO APPROVED FOR
RELEASE 1 JULY 2015

Report No.
TOR-669(6107-40)-1

(U) AN ANALYSIS OF THE REQUIREMENTS FOR
VERY HIGH ACCURACY IMAGE MOTION COMPENSATION

Prepared



R. Grove



A. Mandl



L. E. Watson

Approved



A. G. Nash, Head
Optical and Electrical Department
Sensing and Information Subdivision
Electronics Division



H. W. Nordyke, Director
MOL Experiments Development
Manned Systems Division

UNCLASSIFIED

UNCLASSIFIED
[REDACTED]

CONTENTS

1.0	INTRODUCTION	1-1
2.0	IMAGE MOTION ANALYSIS	1-2
2.1	Vertical Photography	1-3
2.2	Side-Oblique Photography	1-4
2.3	Forward and Forward plus Side-Oblique Photography	1-7
APPENDIX A.	Image Motion Considerations for Vertical and Side-Oblique Photography	A-1
APPENDIX B.	Analysis of Image Motions in a Camera having Forward and Side Orientations	B-1
APPENDIX C.	Some Error Analyses and Design Details for the Forward and Side-Oblique Strip Camera	C-1
APPENDIX D.	Preliminary Design Consideration on a High Accuracy Film Drive Mechanism	D-1

UNCLASSIFIED
[REDACTED]

UNCLASSIFIED

FIGURES

1.	Image Motion: Vertical Photograph	1-4
2.	Image Motion: Side Oblique	1-5
3.	Resultant Image Velocity Vectors	1-5
4.	Image Motion due to Forward, Backward or Forward, or Backward Plus Side-Oblique	1-8

UNCLASSIFIED

UNCLASSIFIED
[REDACTED]

1.0 INTRODUCTION

At the request of the MOL Experiments Development Office, a design and error analysis was initiated to determine the requirements and feasibility of a camera system capable of image motion compensation over the entire image plane to an accuracy of at least 0.1% of the forward velocity component of the vehicle at the image plane. In order to complete such a study it was necessary to perform a detailed analysis of the image motion sources and the associated compensation error tolerances, to investigate in concept various feasible mechanical designs of the camera image motion compensating (IMC) mechanisms, and to perform a detailed analysis of the IMC servo control system design requirements and feasibility based upon the above analysis.

A basic premise of this study was that the image velocity sensing would be done by a man aided tracking system that has the capability to determine the image velocity direction and magnitude to a resultant accuracy far in excess of the required system accuracy of 0.1%. It was assumed that in general the tracking system would be basically as described by the IBM Image Velocity Sensor Subsystem (IVSS) Study Reports (SSD-TR-64-277).

Characteristically, this system employs a variable power, servo controlled, direct viewing, pointing and tracking telescope. The servo controlled tracking elements are used in conjunction with a general purpose computer. Initial tracking rates would be calculated for a given target to appear in the field of view at some azimuth within the limits of the operating system. Automatic tracking would begin at acquisition, and rate corrections would be provided as indicated from manual corrections made by an operator viewing the target and keeping it at a prescribed point in the optical field of view. Accurate data would be provided by the computer regarding the angles and angular velocity of the target line of sight with respect to the spacecraft. Angular rate data would be used to precisely control the synchronized motion of the recording film at the optimum or other prescribed time of photography.

UNCLASSIFIED
-1-
[REDACTED]

UNCLASSIFIED
[REDACTED]

Since this system in actuality employs an open loop operation, it is mandatory that a careful analysis of the design and tolerances of the tracking and camera systems be made so that the required tolerances involved in translating the computed image velocity resulting from the man aided IVSS tracking into precise film drive and other complex motions be understood.

This study is a result of the combined efforts of personnel of the Optical and Electrical Department of the S & I Systems Subdivision and of the Controls Department of the G & C Subdivision. Robert Grove and Lloyd Watson were responsible for the image motion analysis, Al Mandl for the mechanical design considerations, and Darrel Giesecking for the servo systems analysis. Lloyd Watson was also responsible for the coordination of these studies.

The details of the image motion analysis are contained in Appendixes A, B, and C. Appendix D sets forth the mechanical design considerations and the development of a recommended design approach. The details of the IMC servo control system requirements and design study have been issued as a separate report by the Controls Department.

2.0. IMAGE MOTION ANALYSIS

Image motions at the image plane of aerial cameras result from the apparent ground motion due to the forward motion of the vehicle, camera and vehicle angular motions, vibrations and atmospheric disturbances. In this study the atmospheric effects are not considered. The magnitude and direction of the image motion depend upon directions of camera pointing as well as upon the vehicle velocity and altitude and are a function of the lens focal length. Basically, for vertical photography, the image velocity, V_{i0} , is given as

$$V_{i0} = - \frac{V}{H} F \quad (1)$$

UNCLASSIFIED
[REDACTED]

UNCLASSIFIED

NRO APPROVED FOR
RELEASE 1 JULY 2015

where

V = vehicle velocity

H = altitude

F = lens focal length

V_{io} is opposite in direction to the line of flight. However, since the image motion direction is a function of camera pointing or the optical line-of-sight direction, there will be resultant image motion components which are not parallel to the line of flight and may not be in the same direction. These motions have been analyzed as functions of camera pointing angles and the resultant position in the camera focal plane.

Four modes of camera operation are considered. Each gives rise to a unique situation relative to image motion compensation. The modes are

1. Vertical photography
2. Side-oblique photography
3. Forward or backward-oblique photography
4. Forward or backward-oblique plus side-oblique photography.

2.1 VERTICAL PHOTOGRAPHY (Appendix A)

As detailed in Appendix A, the image velocity, resulting from strictly vertical photography, is a function of V/H and lens focal length (Equation 1). Each image motion point in the image plane moves in one direction only and all the resultant motions across the image format are parallel to each other. The direction of the motion is opposite to the forward direction of the camera vehicle. This is shown schematically in Figure 1.

Thus if the film is parallel to and in synchronism with this motion, perfect IMC can be accomplished. The precision of the film drive, the ability to sense and determine the image motion (V/H sensing), and to synchronize the film speed to the image velocity are the critical parameters. Cameras which operate in this fashion and employ a narrow slit across the center of the image

UNCLASSIFIED

UNCLASSIFIED

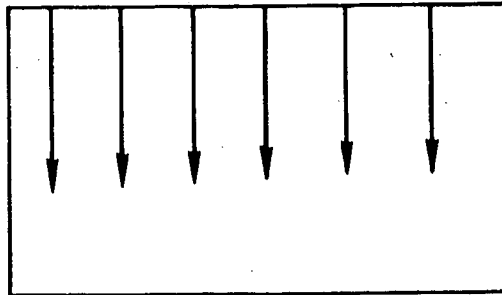

Figure 1. Image Motion: Vertical Photography

plane to control exposure are in common use. For this simple case, limited by the film drive mechanism alone, precisions approaching 0.1% are rarely achieved at present even in the laboratory.

2.2 SIDE-OBLIQUE PHOTOGRAPHY

Since it is not always possible to pass directly over an area of interest so that vertical photography can be accomplished, it generally is necessary to provide a means for accomplishing side-oblique photography. Also from Appendix A, it was shown that the resultant image motion, V_{is} , is given by

$$V_{is} = \frac{V_o}{H} F(\cos \theta + \sin \theta \tan \Delta\theta) \quad (2)$$

where

V_o is the apparent ground velocity

θ is the obliquity or roll angle (from the local vertical to the center of the optical axis)

$\Delta\theta$ is the angle of a point off axis.

Since $\Delta\theta$ can be positive or negative with respect to θ , it is readily apparent that, although the resultant image motion vectors are parallel to each other, they differ in magnitude, increasing from the corresponding greater distance edge of the image to the lesser.

UNCLASSIFIED

UNCLASSIFIED

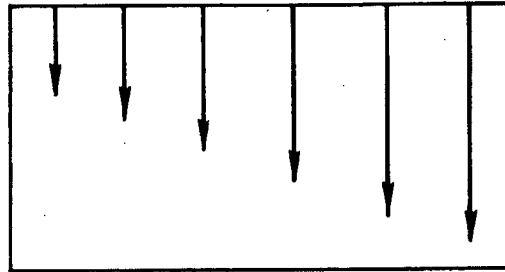

Figure 2. Image Motion: Side Oblique

Therefore, no single film velocity can compensate for the motion across the film width. If the film is driven at a speed corresponding to that at the center, on the optical axis, then resultant image motion vectors will be as indicated by Figure 3.

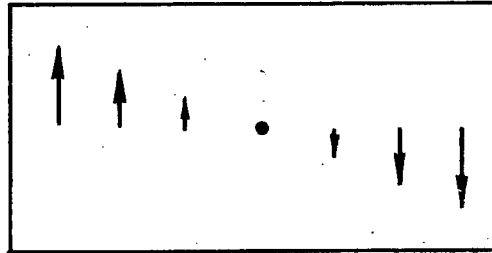

Figure 3. Resultant Image Velocity Vectors

However, by rotating the film platen (image plane) while the film is being driven at the IMC speed, the resultant velocities can be reduced to zero. The required rotational rate, ω_p of the platen, is also a function of the V/H as well as the obliquity angle and must correspond to

$$\omega_p = \frac{V_o}{H} \sin \theta \quad (3)$$

UNCLASSIFIED

UNCLASSIFIED

However, as noted in Appendix A, it is now necessary to translate the image plane laterally in a direction parallel to the initial slit orientation. This is required because, as the image plane (film platen) is rotated, the film is no longer being driven in a direction parallel to the motion at the optical center, thus a cross track error is introduced. The required compensating translational motion, V_t , will be

$$V_t = \frac{1}{2} TF \left(\frac{V}{H} \right)^2 \sin 2\theta \quad (4)$$

All three motions will be required if a system accuracy approaching 0.1% is achieved. Since other system errors will likely occur, such as in pointing, optical alignment, motion sensing, vibration, etc., the required precision of the IMC due to the servo controlled mechanical drive systems should be somewhat better than the required 0.1%. Where three simultaneous motions are required it was decided that each should not contribute more than half of the above tolerance or be in error more than $0.0005 V_o$. Combined in an RMS fashion this would allow a net average error attributable to the servo controlled drive systems of approximately $0.0008 V_o$.

The maximum allowable error for each of the separate drive motions, so that the $0.0005 V_o$ tolerance will not be exceeded, will be

$$\text{Film drive error: } e_f = 0.0005 V_o \quad (5)$$

or 0.05%

$$\text{Rotational drive error: } e_r = \frac{0.0005 F}{d \tan \theta} \quad (6)$$

where d is the distance along the slit from the optical center.

UNCLASSIFIED

UNCLASSIFIED

Assuming that the most stringent case would be at a side-obliquity angle, θ , of about 45 degrees and a total exposing time (frame time) of 5 seconds then $e_r = 0.035$ or a rotational drive error of $\pm 3.5\%$ could be tolerated.

$$\text{Translational drive error: } e_t = \frac{V_o}{V_t} = \frac{0.0005}{t \frac{V}{H} \sin \theta} \quad (7)$$

Assuming the same conditions as for (6), the translational drive accuracy could be $\pm 0.2\%$.

2.3 FORWARD AND FORWARD PLUS SIDE - OBLIQUE PHOTOGRAPHY (Appendix B)

It is possible to obtain stereo photography using only one camera and lens system providing that the pictures of the object space can be obtained from two different viewing angles or optical lines of sight commonly referred to as the stereo angle. The stereo angle is not critical and can vary from 2 or 3 degrees to many degrees but with some variation in the apparent stereo effect to be expected.

If stereo photography is desired from a satellite vehicle having only one camera system, then it becomes necessary to point the optical axis forward and backward, or forward plus side-oblique and backward plus side-oblique in order to obtain the stereo pairs. In doing so, the image motion components are not readily apparent and the image motion compensation might be complex. These modes of operation generally would be considered only if stereo photography were a requirement.

As noted in Appendix B, the image velocities resulting from forward or backward-oblique photography vary nonlinearly across the image plane. With reference to a vanishing point located on the horizon which is the intersection of the the horizon line and the flight line, the image velocities will be as shown in Figure 4.

UNCLASSIFIED

UNCLASSIFIED

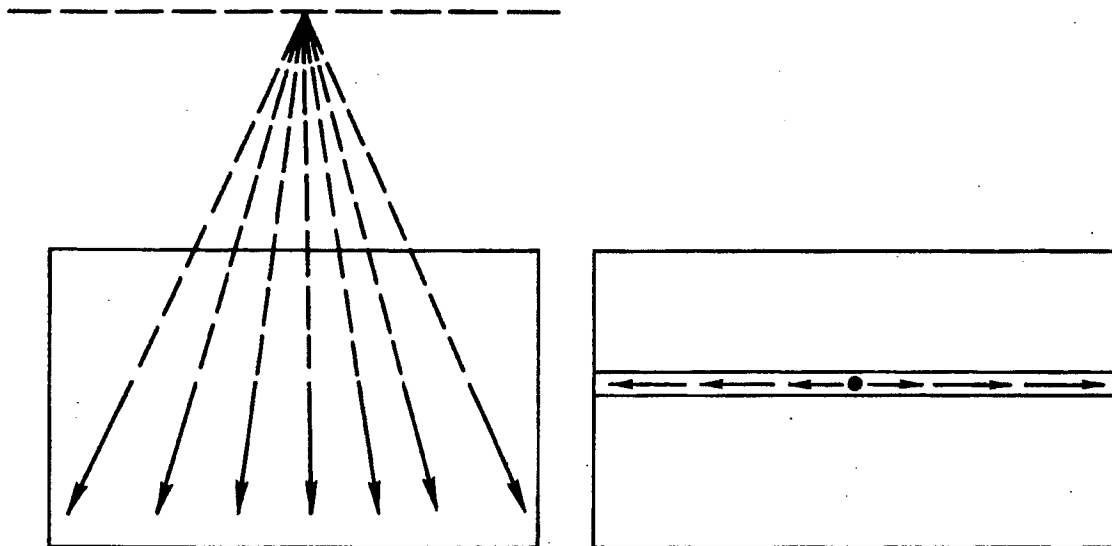

Figure 4. Image Motion Due to Forward, Backward or Forward, or Backward Plus Side-Oblique

Considering a slit across the film it is noted that the image velocities perpendicular to the slit are constant and can be removed by the proper film speed. The resultant image velocities along the slit are linear with position and therefore can be removed by a motion that changes the image size by a prescribed rate. The most likely way to accomplish this would be by a controlled zoom (Appendix D). Forward or backward-oblique plus side-oblique photography result in the same situation as the above, hence the corrections are made in the same way. It should be noted that in compensating for this cross track motion component by "zooming" changes the image velocity along the optical axis, because of the increase or decrease in the lens focal length. Hence the film drive must be continuously variable over this range.

The total image motion, V_{io} , at the image plane in this mode is given by

$$V_{io} = F \frac{V}{H} \cos^2 \rho \cos \theta \exp\left(-\frac{V}{H} \sin \rho \cos \theta t\right) \quad (8)$$

UNCLASSIFIED

UNCLASSIFIED

where

ρ is the pitch angle

θ is the roll angle

t is the time duration of photography

The image motion component (V'_{i0}) perpendicular to the slit corresponding to the film drive rate is

$$V'_{i0} = F \frac{V}{H} \cos^2 \rho \cos \theta \quad (9)$$

and must be accurate to about 0.05 to 0.06% if the desired IMC is achieved.

The image motion component, V''_{i0} , along the slit is

$$V''_{i0} = \exp\left(\frac{1}{2} \frac{Vd}{H} \sin \rho \cos \rho \cos \theta\right) \quad (10)$$

where d is the distance measured along the slit from the optical center.

If the maximum error allowable for this component is also 0.0005 V_{i0} , the fractional error of the zoom drive is given by

$$\frac{\Delta F}{F} = 0.001 \frac{1}{\tan \rho} \frac{F}{d} \quad (11)$$

For the most severe case of 30 deg forward oblique, and for a format dimension (d) of 1 foot and a focal length of 20 feet, the zoom drive accuracy is found to be 3-1/2%.

UNCLASSIFIED

UNCLASSIFIED

APPENDIX A

IMAGE MOTION CONSIDERATIONS FOR VERTICAL
AND SIDE-OBLIQUE PHOTOGRAPHY

1.0 VERTICAL PHOTOGRAPHY

The relationships of image motion with altitude and vehicle velocity are well known in aerial photography. As can be seen from Figure A-1, the image velocity, V_{io} , at the optical center is

$$V_{io} = -\frac{V}{H}F \quad (A-1)$$

where

V = apparent ground velocity

H = altitude

F = lens focal length

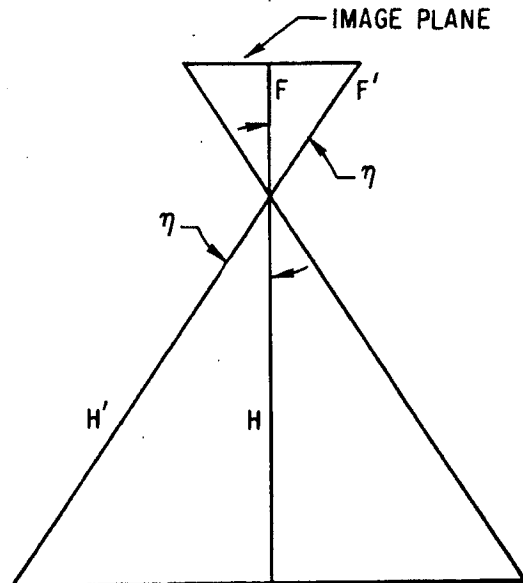

Figure A-1. Geometric Relationship Between Ground Motion and Image Motion for Vertical Photography

UNCLASSIFIED

UNCLASSIFIED

Also, considering an object point off the optical axis by an angle η , then the image motion corresponding to that point in the image plane will be

$$V'_{i\eta} = -F' \frac{V}{H'} \quad (A-2)$$

Since

$$F' = \frac{F}{\cos \eta} \text{ or } F \sec \eta \quad (A-3)$$

and

$$H' = \frac{H}{\cos \eta} \text{ or } H \sec \eta \quad (A-4)$$

substituting in Equation (A-2) results in

$$V_{i\eta} = -\frac{V}{H} F \quad (A-5)$$

Thus, the image motion across the field of view for vertical photography is the same as at the optical axis.

2.0 SIDE-OBLIQUE PHOTOGRAPHY

The image motion relationships for side-oblique photography can best be seen by referring to Figure A-2. In this figure, H is the altitude and M the slant range to the center of the field of view along the optical axis. θ is the obliquity angle or the roll angle. $\Delta\theta$ is an off-axis angle.

Since $M = H \sec \theta$, the image velocity at the optical center is

$$V_{io} = F \frac{V_o}{H \sec \theta} = \frac{FV_o}{H} \cos \theta \quad (A-6)$$

UNCLASSIFIED

UNCLASSIFIED

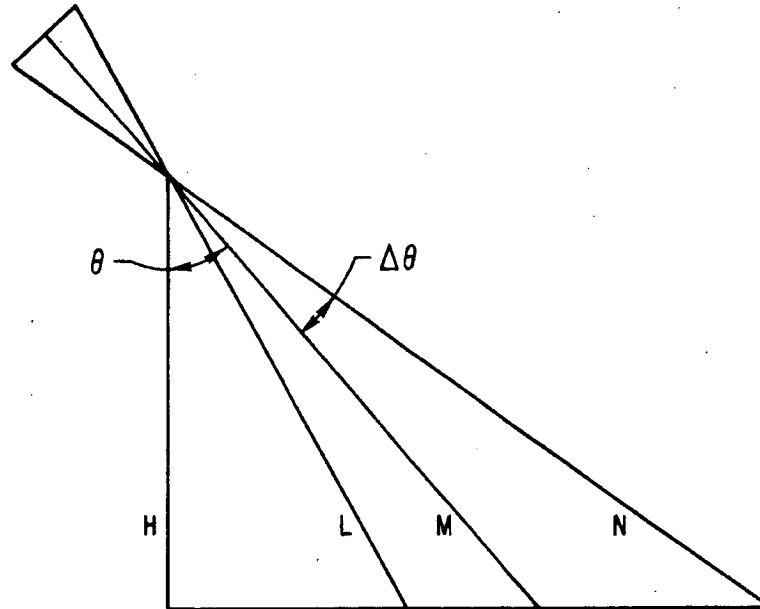

Figure A-2. Geometric Relationship Between Ground Motion and Image Motion for Side-Oblique Photography

Considering an object off axis by an amount $\Delta\theta$, then

$$V_{i\Delta\theta} = \frac{V_o F \sec \Delta\theta}{H \sec(\theta + \Delta\theta)} \quad (A-7)$$

$$= \frac{V_o F}{H} (\cos \theta - \sin \theta \tan \Delta\theta)$$

The velocity increment along a slit perpendicular to the direction of motion, measured from the optical axis, is the difference of equations (A-7) and (A-6) or

$$V_{i\Delta\theta} - V_{io} = \frac{V_o F}{H} (\cos \theta - \sin \theta \tan \Delta\theta) - \frac{V_o F}{H} \cos \theta \quad (A-8)$$

$$= - \frac{V_o F}{H} (\sin \theta \tan \Delta\theta)$$

UNCLASSIFIED

UNCLASSIFIED

It should be noted that in reference to the motion at the optical center, this may be greater or smaller than V_{i0} depending upon whether $\Delta\theta$ is positive or negative. Thus the image motion, although parallel, is varied continuously in magnitude from the nearest to the farthest point across the field.

If the film plane (or platen) is rotated about the optical axis during the exposing interval with an angular velocity, ω , when the slit is perpendicular to the flight line, there will be a velocity increment given to the film which is $d\omega$, where d is the distance from the optical axis measured along the slit. Then

$$\Delta V = d\omega \quad (A-9)$$

But

$$d = F \tan \Delta\theta \quad (A-10)$$

Substituting (A-9) and (A-10) into (A-8) for $V_i\Delta\theta - V_{i0}$ gives

$$F\omega \tan \Delta\theta = \frac{V_o F}{H} (\sin \theta \tan \Delta\theta) \quad (A-11)$$

Thus it is seen that the compensation is exact and independent of the angular field of the optical system when the platen is in this orientation. The required angular velocity is

$$\omega = \frac{V_o}{H} \sin \theta \quad (A-12)$$

Although this rotational motion can completely compensate for the non-uniform motion resulting from side-oblique photography, in so doing another secondary motion is introduced. Assuming that the film drive is a cylindrical

UNCLASSIFIED

UNCLASSIFIED

platen, as it is rotated about the optical axis, after time, t , the drum has rotated an angle, α , and the direction of film drive has also changed by an amount α from the desired direction, (Figure A-3) where α is given by

$$\alpha = \omega t \tag{A-13}$$

and t is the total frame time.

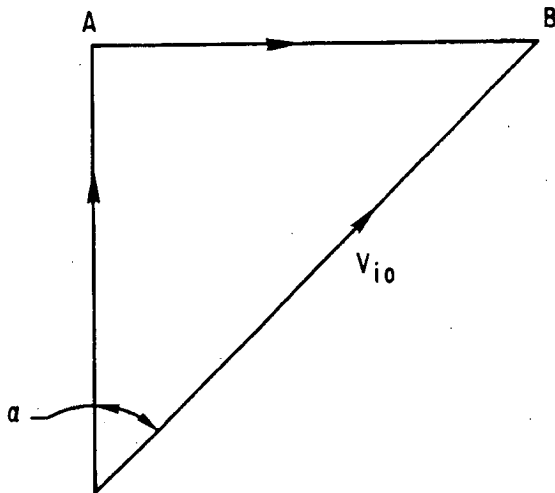

Figure A-3. Vector Diagram of Film Image Motion After Drum Rotation

The image motion, imparted by drum rotation, along the slit in the direction of A to B is then

$$V_t = V_{i0} \sin \alpha = V_{i0} \sin \omega t$$

or

$$V_t = \frac{1}{2} F \left(\frac{V_o}{H} \right)^2 t \sin 2\theta \tag{A-14}$$

This image motion must therefore be compensated by translating the drum a like amount along its primary spin axis.

We are now prepared to consider the allowed errors in each of these three motions of the drum; these are $\Delta V_{i0}/V_{i0}$, $\Delta\omega/\omega$, and $\Delta V_t/V_t$.

UNCLASSIFIED

UNCLASSIFIED

Since the RSS of these errors should yield no more than 0.001 fractional error in film speed, then it should be reasonable to allot 0.0005 fractional error to each of these error sources.

It is immediately apparent that the primary drum rotation error ($\Delta V_{i0}/V_{i0}$) must not exceed 0.0005. The other errors are more subtle. An error in the secondary angular rotation rate of the drum ($\Delta\omega$) will cause an error in film speed at the edge of the format (Δd) of

$$\Delta d = d\Delta\omega \quad (A-15)$$

Allowing

$$\Delta d = 0.0005 V_{i0} \quad (A-16)$$

and dividing (A-15) by (A-16) yields

$$\frac{\Delta\omega}{\omega} = 0.0005 \frac{V_{i0}}{d\omega} \quad (A-17)$$

Substituting (A-6) and (A-12) into (A-17) yields

$$\frac{\Delta\omega}{\omega} = 0.0005 \frac{F}{d \tan \theta} \quad (A-18)$$

Assuming, F to be 20 feet, d = 0.5 foot, and $\theta = 30^\circ$, then

$$\frac{\Delta\omega}{\omega} = 0.035 = 3 \frac{1}{2} \% \quad (A-19)$$

In other words, a 3-1/2% error in the secondary rotation rate of the drum will yield 1/20% error in film speed at the edges of the format.

UNCLASSIFIED

UNCLASSIFIED

The allowed error in drum translation (ΔV_t) is assumed to be

$$\Delta V_t = 0.0005 V_{i0} \quad (A-20)$$

Dividing by V_t

$$\frac{\Delta V_t}{V_t} = 0.0005 \frac{V_{i0}}{V_t} \quad (A-21)$$

Substituting (A-6) and (A-14) into the right hand side of (A-21) yields

$$\frac{\Delta V_t}{V_t} = \frac{0.0005}{V_{o/H}^t \sin \theta} \quad (A-22)$$

Allowing $V_{o/H} = 0.04$ radian/sec, $\theta = 30^\circ$, and $t = 5$ seconds, then

$$\frac{\Delta V_t}{V_t} = 0.5 \times 10^{-2} = 0.5\% \quad (A-23)$$

In other words, a 0.5% error in drum translation speed will yield a 0.05% error in film speed.

UNCLASSIFIED

UNCLASSIFIED

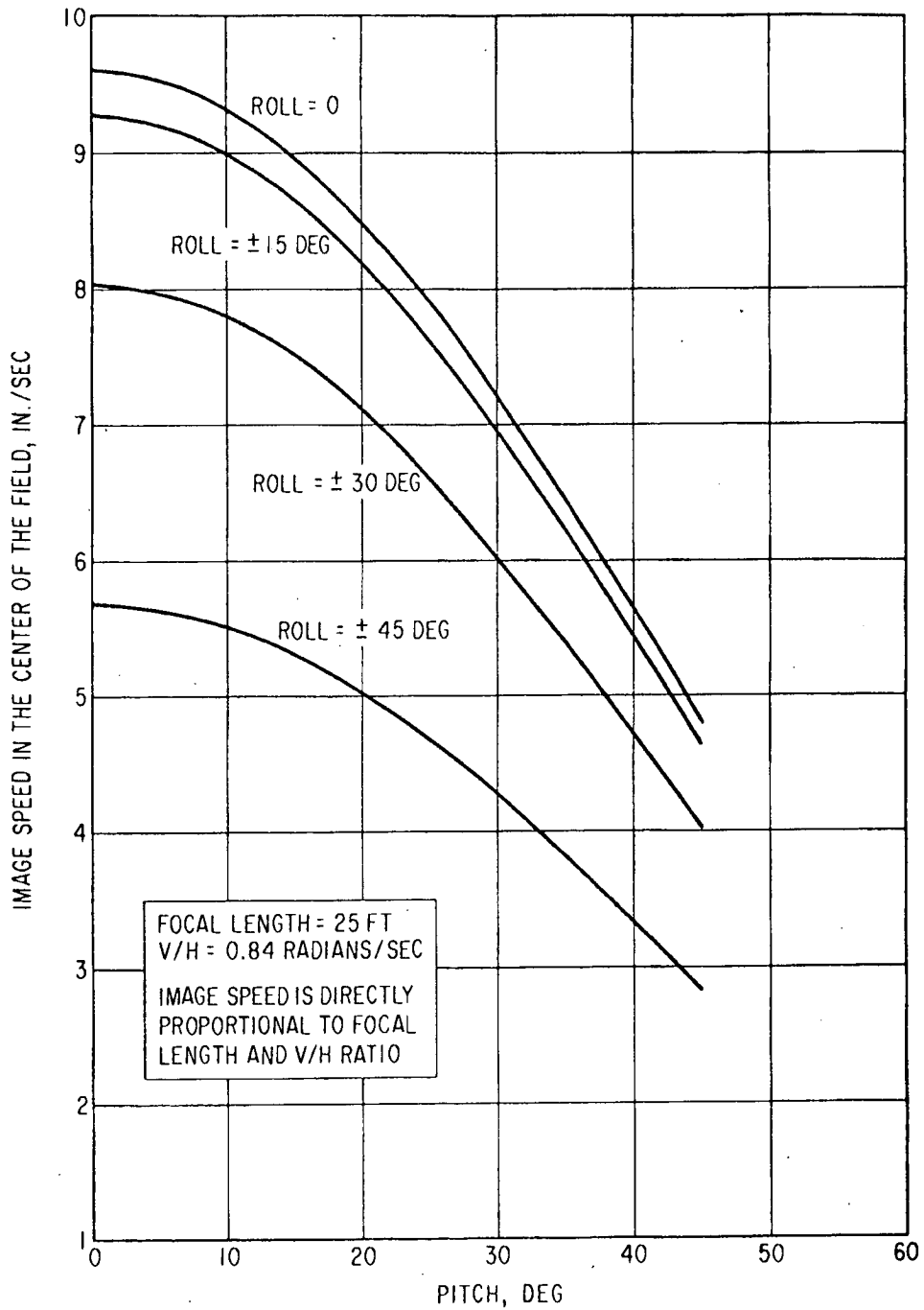

Figure A-4. Image Speed as a Function of Pitch and Roll for Cameras Pointing Forward and to the Side

UNCLASSIFIED

UNCLASSIFIED

APPENDIX B

ANALYSIS OF IMAGE MOTIONS IN A CAMERA HAVING
FORWARD AND SIDE ORIENTATIONS

Envision a camera system oriented as shown in Figure B-1 with a cartesian coordinate system (x, y, z) whose xy plane defines the ground plane of a flat earth. Let the origin be fixed in the nadir point of the camera whose focal length is F . If the travel of the camera is "horizontal" and in the y direction the ground points will appear to be moving in the $-y$ direction. Let the camera be at an altitude H and l_x, l_y, l_z be unit vectors along the directions of the x, y and z coordinates respectively. Let any particular ground point be defined by the vector \bar{G} .

Envision a second coordinate system (x'', y'', z'') where l_x'', l_y'', l_z'' are unit vectors along the directions of the $x'', y'',$ and z'' axes respectively. Let the origin be located at the camera nodal point. Let the image plane be a plane parallel to the $x''y''$ plane. Let the principal ray from the ground point \bar{G} intersect the image plane at the head of the vector \bar{I} . The tail of the vector \bar{I} is bound in the camera nodal point. The vector $K\bar{I}$ measured from the ground point \bar{G} to the camera nodal point also lies along the principal ray and, of course, has the same orientation as \bar{I} but is K times longer.

From Figure B-1 we obtain the following three equations

$$\bar{G} + K\bar{I} = Hl_z \quad (B-1)$$

$$\bar{I} = l_x'' x_i + l_y'' y_i + l_z'' F \quad (B-2)$$

$$\bar{G} = l_x x_g + l_y y_g \quad (B-3)$$

UNCLASSIFIED

UNCLASSIFIED

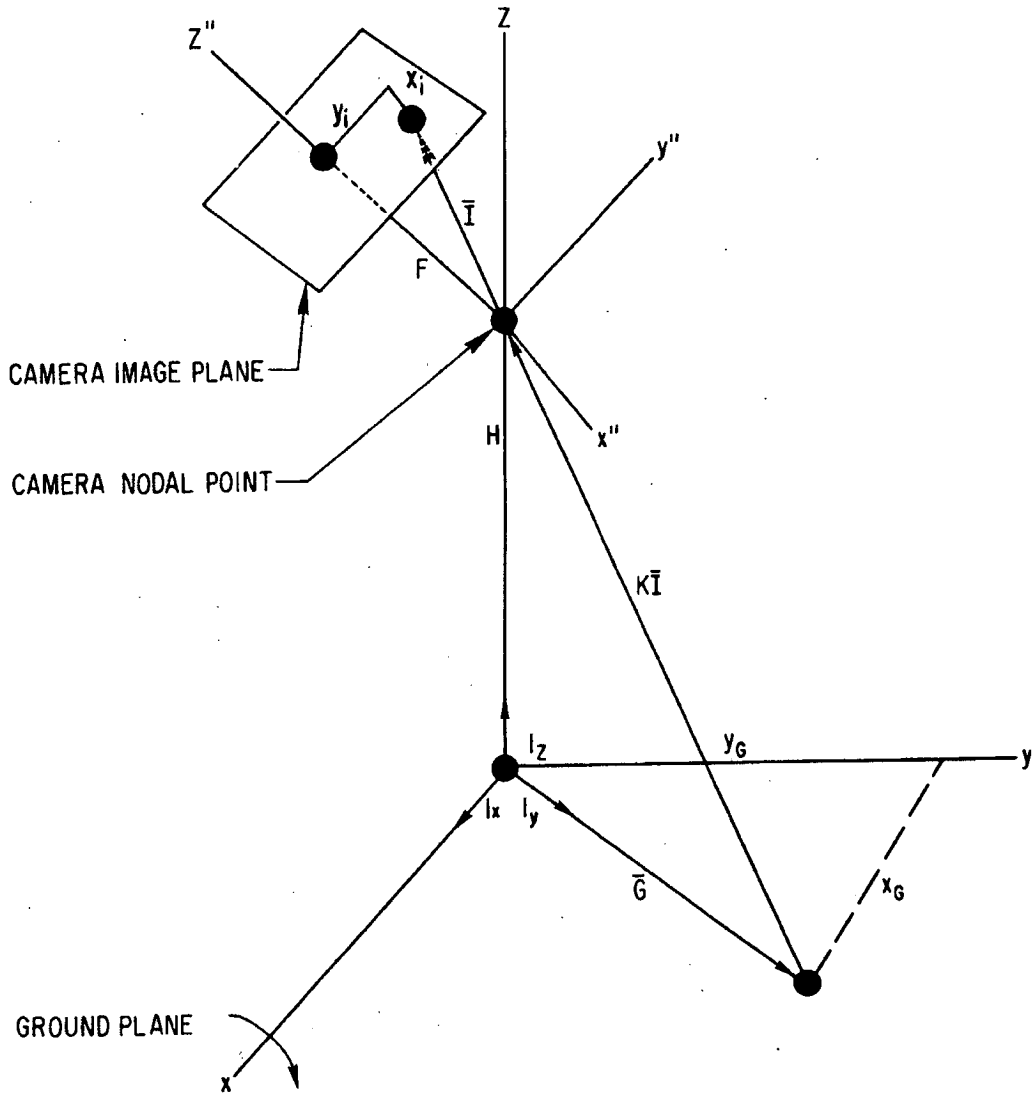

Figure B-1. Relations of Principal Vectors in the Ground and Camera Coordinate Systems

UNCLASSIFIED

UNCLASSIFIED

where

- \bar{G} is the vector from the camera nadir point to any ground point on a flat earth
- y_g is the coordinate of the ground point in the forward direction
- x_g is the coordinate of the ground point in the side direction
- \bar{T} is the vector from the camera nodal point to the image of the ground point in the camera image plane
- x_i, y_i are coordinates of the image point in the image plane measured from the optical axis
- F is the camera focal length
- H is the camera latitude
- K is a proportionality constant
- l_x, l_y, l_z are unit vectors in the ground coordinate system in which the z direction is up, the y direction is forward, and the x direction is to the side (as defined for a right handed coordinate system)
- l_x'', l_y'', l_z'' are unit vectors in the camera coordinate system in which the z'' direction is along the optical axis, and the x'' and y'' directions are defined in the image plane.

Eliminating \bar{G} and \bar{T} from equations (B-1), (B-2), and (B-3) yields

$$l_x'' K x_i + l_y'' + l_z'' K F = - l_x x_g - l_y y_g + l_z H \quad (B-4)$$

Useful relationships between the two coordinate systems can be obtained by assuming that the camera is oriented vertically. In this special case

$$\left. \begin{aligned} l_x'' &= l_x \\ l_y'' &= l_y \\ l_z'' &= l_z \end{aligned} \right\} \text{Vertically Oriented Camera}$$

UNCLASSIFIED

Let us now pitch the camera forward by an angle ρ . In this special case let

$$\left. \begin{aligned} l'_x &= l_x \\ l'_y &= l_y \\ l'_z &= l_z \end{aligned} \right\} \text{Camera pitched forward only.}$$

Then from Figure B-2 we have

$$\left. \begin{aligned} l''_x &= l'_x \\ l''_y &= l'_y \cos \rho + l'_z \sin \rho \\ l''_z &= l'_y \sin \rho + l'_z \cos \rho \end{aligned} \right\} \text{(B-5)}$$

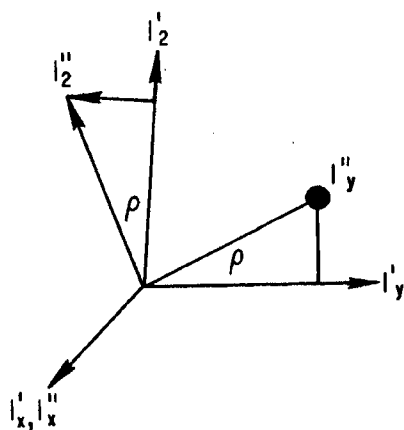

Figure B-2. Relation Between Unit Vectors of the Camera to Intermediate Coordinate Systems

Since the equations that follow tend to become lengthy, the trigonometric forms are presented more compactly than is common practice. As an example let the trigonometric functions of some angle ϕ be written as

$$\sin \phi = S_{\phi}$$

$$\cos \phi = C_{\phi}$$

$$\tan \phi = T_{\phi}$$

UNCLASSIFIED

Using this compact form (B-5) becomes

$$\left. \begin{aligned} l''_x &= l'_x \\ l''_y &= l'_y C_\rho + l'_z S_\rho \\ l''_z &= -l'_y S_\rho + l'_z C_\rho \end{aligned} \right\} \quad (B-6)$$

Now roll the camera an angle θ . Then from Figure B-3 we have

$$\left. \begin{aligned} l'_x &= l_x C_\theta + l_z S_\theta \\ l'_y &= l_y \\ l'_z &= -l_x S_\theta + l_z C_\theta \end{aligned} \right\} \quad (B-7)$$

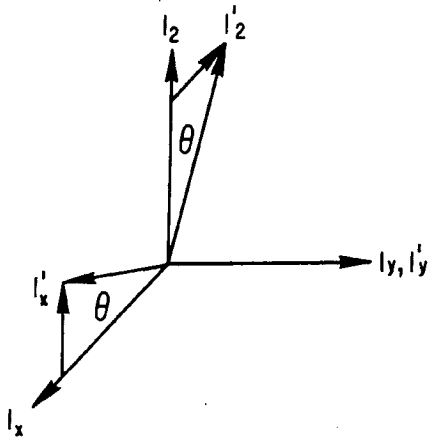

Figure B-3. Relation Between Unit Vectors of the Intermediate to the Ground Coordinate Systems

Substituting (B-7) into (B-6) yields

$$\left. \begin{aligned} l''_x &= l_x C_\theta + l_z S_\theta \\ l''_y &= -l_x S_\rho S_\theta + l_y C_\rho + l_z S_\rho C_\theta \\ l''_z &= -l_x C_\rho S_\theta - l_y S_\rho + l_z C_\rho C_\theta \end{aligned} \right\} \quad (B-8)$$

UNCLASSIFIED

UNCLASSIFIED

A useful relationship now exists between the two coordinate systems. Equations (B-8) give the camera unit vectors in terms of the ground unit vectors.

Substituting (B-8) into (B-4) and equating vectorial coefficients yields

$$K(C_{\theta}x_i - S_{\rho}S_{\theta}y_i - C_{\rho}S_{\theta}F) = -x_g \quad (B-9)$$

$$K(C_{\rho}y_i - S_{\rho}F) = -y_g \quad (B-10)$$

$$K(S_{\theta}x_i + S_{\rho}C_{\theta}y_i + C_{\rho}C_{\theta}F) = H \quad (B-11)$$

Since K is a constant of little significance, it can be eliminated by first dividing (B-9) by (B-11) and then (B-10) by (B-11). This procedure yields

$$\frac{x_g}{H} = -\frac{C_{\theta}x_i - S_{\rho}S_{\theta}y_i - C_{\rho}S_{\theta}F}{S_{\theta}x_i + S_{\rho}C_{\theta}y_i + C_{\rho}C_{\theta}F} \quad (B-12)$$

and

$$\frac{y_g}{H} = -\frac{C_{\rho}y_i - S_{\rho}F}{S_{\theta}x_i + S_{\rho}C_{\theta}y_i + C_{\rho}C_{\theta}F} \quad (B-13)$$

Equations (B-12) and (B-13) are important because they give the relationship between any ground point coordinates (x_g, y_g) and their image coordinates (x_i, y_i) as a function of camera altitude, focal length, and orientation (H, F, ρ, θ) .

The fundamental purpose in performing this analysis is to determine the image motions as a function of satellite travel, with the ultimate hope of finding a suitable method of image motion compensation. The next step is therefore to find relationships for image motion.

UNCLASSIFIED

UNCLASSIFIED

This can best be done by differentiating (B-12) and (B-13) with respect to time and rearranging the resultant equations. The algebraic manipulations required are lengthy and are therefore not presented here. The procedure required, however, is discussed below.

The ground coordinate system was originally defined with the y axis as the direction of satellite travel. Since the ground coordinate system travels with the satellite, all the ground points appear to be travelling in the negative y direction or

$$\left. \begin{aligned} \frac{dy_g}{dt} &= -V \\ \frac{dx_g}{dt} &= -0 \end{aligned} \right\} \quad (B-14)$$

where V is satellite velocity.

In order to keep the equations compact, the notation of a single dot is used above a variable to represent that variable's derivative with respect to time, i. e.,

$$\dot{q} = \frac{dq}{dt}$$

Employing this notation modifies (B-14) as follows

$$\dot{y}_g = -V, \quad \dot{x}_g = 0 \quad (B-15)$$

The procedure employed took the following steps:

1. Differentiate (B-12) and (B-13) with respect to time. x_i and y_i are variables and F, H, ρ , and θ are constants. This step yields two equations both containing \dot{x}_i and \dot{y}_i in addition to x_i , y_i , F, ρ , and θ .

UNCLASSIFIED

2. Substitute (B-15) into the two equations.
3. Solve the two equations for \dot{x}_i and \dot{y}_i in terms of x_i , y_i , F , ρ , and θ . This last step yields the important relationships of

$$\dot{x}_i = \frac{1}{F} \frac{V}{H} S_\rho x_i (S_\theta x_i + S_\rho C_\theta y_i + C_\rho C_\theta F) \quad (\text{B-16})$$

and

$$\dot{y}_i = \frac{1}{F} \frac{V}{H} (S_\rho y_i + C_\rho F) (S_\theta x_i + S_\rho C_\theta y_i + C_\rho C_\theta F) \quad (\text{B-17})$$

Study of Equations (B-16) and (B-17) is difficult because they are complicated. Let us try various coordinate transformations in order to simplify them.

First establish the coordinates for the image of the horizon line. The horizon line is the line for which $y_g \rightarrow \infty$. Inspection of (B-13) shows that $y_g \rightarrow \infty$ when the denominator $\rightarrow 0$ or

$$S_\theta x_{iH} + S_\rho C_\theta y_{iH} + C_\rho C_\theta F = 0 \quad (\text{B-18})$$

where x_{iH} and y_{iH} are image plane coordinates of all points on the horizon.

Now establish the coordinates for the image of the flight line. The flight line is the line for which $x_g = 0$. Inspection of (B-12) shows that $x_g = 0$ when the numerator is zero or

$$C_\theta x_{iF} - S_\rho S_\theta y_{iF} - C_\rho S_\theta F = 0 \quad (\text{B-19})$$

where x_{iF} and y_{iF} are image plane coordinates of all points on the flight line.

UNCLASSIFIED

Now determine the point where the horizon line and flight line intersect. Call this point the vanishing point with coordinates x_{iv} , y_{iv} . This point is the simultaneous solution of (B-18) and (B-19), yielding

$$x_{iv} = 0, y_{iv} = -F \frac{C}{S_{\rho}} \quad (B-20)$$

Now translate the coordinate system in the image plane such that its origin is at the vanishing point, or let

$$\begin{aligned} x_i &= x_v \\ y_i &= y_v - F \frac{C}{S_{\rho}} \end{aligned} \quad (B-21)$$

Substituting (B-21) into (B-16), (B-17), (B-18), and (B-19) yields

$$\dot{x}_v = \frac{1}{F} \frac{V}{H} S_{\rho} x_v (S_{\theta} x_v + S_{\rho} C_{\theta} y_v) \quad (B-21a)$$

and

$$\dot{y}_v = \frac{1}{F} \frac{V}{H} S_{\rho} y_v (S_{\theta} x_v + S_{\rho} C_{\theta} y_v) \quad (B-22)$$

and for the horizon line

$$S_{\theta} x_{vH} + S_{\rho} C_{\theta} y_{vH} = 0 \quad (B-23)$$

and for the flight line

$$S_{\theta} x_{vF} - S_{\rho} S_{\theta} y_{vF} = 0 \quad (B-24)$$

UNCLASSIFIED

UNCLASSIFIED

Now rotate the coordinate system such that the horizon line is in the x direction. In order to accomplish that let

$$x_v = \frac{1}{\sqrt{1 + \left(\frac{S_\rho}{T_\theta}\right)^2}} \left(\frac{S_\rho}{T_\theta} x + y \right) \quad (\text{B-25})$$

and

$$y_v = \frac{1}{\sqrt{1 + \left(\frac{S_\rho}{T_\theta}\right)^2}} \left(-x + \frac{S_\rho}{T_\theta} y \right) \quad (\text{B-26})$$

Substituting (B-25) and (B-26) into (B-21), (B-22), (B-23), and (B-24) yields

$$\frac{S_\rho}{T_\theta} \dot{x} + \dot{y} = + \frac{1}{F} \frac{V}{H} S_\rho S_\theta \sqrt{1 + \left(\frac{S_\rho}{T_\theta}\right)^2} y \left(\frac{S_\rho}{T_\theta} x + y \right) \quad (\text{B-27})$$

$$\dot{x} - \frac{S_\rho}{T_\theta} \dot{y} = + \frac{1}{F} \frac{V}{H} S_\rho S_\theta \sqrt{1 + \left(\frac{S_\rho}{T_\theta}\right)^2} y \left(x - \frac{S_\rho}{T_\theta} y \right) \quad (\text{B-28})$$

$$y_H = 0 \quad (\text{B-29})$$

$$x_F + \frac{S_\theta C_\theta C_\rho}{T_\rho} y_F = 0 \quad (\text{B-30})$$

Multiplying (B-28) by S_ρ/T_θ and subtracting from (B-27) yields

$$\dot{y} = \frac{1}{F} \frac{V}{H} S_\rho S_\theta \sqrt{1 + \left(\frac{S_\rho}{T_\theta}\right)^2} y^2 \quad (\text{B-31})$$

UNCLASSIFIED

Multiplying (B-27) by S_ρ/T_θ and adding to (B-28) yields

$$\dot{x} = \frac{1}{F} \frac{V}{H} S_\rho S_\theta \sqrt{1 + \left(\frac{S_\rho}{T_\theta}\right)^2} xy \quad (\text{B-32})$$

The optical axis is given by

$$x_{is} = y_{is} = 0 \quad (\text{B-33})$$

Substituting (B-33) into (B-21) yields

$$x_{vo} = 0, \quad y_{vo} = F/T_\rho \quad (\text{B-34})$$

Substituting (B-34) into (B-25) and (B-26) yields

$$x_o = -F \frac{1}{T_\rho \sqrt{1 + \left(\frac{S_\rho}{T_\theta}\right)^2}}, \quad y_o = F \frac{C_\rho}{T_\theta \sqrt{1 + \left(\frac{S_\rho}{T_\theta}\right)^2}} \quad (\text{B-35})$$

where x_o and y_o are the coordinates of the optical axis in the final camera coordinate system.

We are now prepared to analyze our image motions. Consider Equations (B-31) and (B-32). It can be seen that, for a given satellite altitude, camera focal length, and orientation the only variables are \dot{x} , \dot{y} , x , and y . That is

$$\begin{aligned} \dot{y} &= K_1 y^2 \\ \dot{x} &= K_1 xy \end{aligned} \quad (\text{B-36})$$

UNCLASSIFIED

where

$$K_1 = \frac{1}{F} \frac{V}{H} S_\rho S_\theta \sqrt{1 + \left(\frac{S_\rho}{T_\theta}\right)^2}$$

and is constant for a given picture taking mission.

Let us examine (B-36) closely. It can be seen that the image velocities vary non-linearly across the image plane. Therefore rotations about the optical axis or other point or zooming cannot possibly correct for image plane errors because these motions provide linear corrections. We may therefore conclude that

No framing camera can possibly be built for forward and side-oblique photography with proper IMC across the image plane with exclusively linear compensations such as lens motions, film motions, camera rotations, and zooming.

Let us now consider a strip camera. In such a camera, IMC is not required across the entire image plane but is required merely on one line in the image plane. When a slit is chosen such that

$$y = y_0, \quad (B-37)$$

and (B-37) is substituted into (B-36), it is found that

$$\left. \begin{aligned} \dot{y} &= K_1 y_0^2 \quad \text{which is constant,} \\ \text{and } \dot{x} &= (K_1 y_0) x \quad \text{which is linear in } x. \end{aligned} \right\} \quad (B-38)$$

It is therefore found that image velocities perpendicular to the slit (\dot{y}) are constant and can be removed entirely by film travel. It is also found that image velocities along the slit (\dot{x}) are linear with position on the slit and therefore can be removed entirely by a combination of film travel and continuous image size change

UNCLASSIFIED

UNCLASSIFIED

which might be accomplished by continuously varying the focal length as accomplished by a zoom lens system. We may therefore conclude that

A strip camera can be built for forward and/or side oblique photography, with theoretically perfect IMC provided we allow for film travel and zooming, and also provided that the slit is horizontal (equivalent to saying that $y = \text{constant}$). It should be pointed out that the straight side oblique situation is a special case and can be compensated only by film travel, rotation and translation of the film platen.

The discussion will now be restricted to a strip camera for forward and forward-side-oblique photography. Let us now consider the image motion that must be corrected in the strip camera.

Place the slit so that it is horizontal and contains the optical axis. Let the coordinates of the slit be (x_s, y_s) . Since the slit is horizontal: $y_s = y_o$. From (B-35) we have

$$y_s = F \frac{C_p}{T_\theta \sqrt{1 + \left(\frac{S_p}{T_\theta}\right)^2}} \quad (\text{B-39})$$

Further let

$$x_s = x_o + \Delta x \quad (\text{B-40})$$

where

Δx is position along the slit measured with respect to the optical axis.

Substituting (B-35) into (B-40) yields

$$x_s = \Delta x - F \frac{1}{T_\rho \sqrt{1 + \left(\frac{S_p}{T_\theta}\right)^2}} \quad (\text{B-41})$$

UNCLASSIFIED

UNCLASSIFIED

Substituting (B-39) and (B-41) into (B-31) and (B-32) yields

$$\dot{y}_s = F \frac{V}{H} \frac{C_\rho^2 C_\theta}{\sqrt{1 + \left(\frac{S_\rho}{T_\theta}\right)^2}} \cdot \frac{S_\rho}{T_\theta} \quad (\text{B-42})$$

and

$$\dot{x}_s = -F \frac{V}{H} \frac{C_\rho^2 C_\theta}{\sqrt{1 + \left(\frac{S_\rho}{T_\theta}\right)^2}} + \frac{V}{H} S_\rho C_\rho C_\theta \Delta x \quad (\text{B-43})$$

From (B-42) and (B-43) the image motion on the optical axis is

$$\dot{y}_o = F \frac{V}{H} \frac{C_\rho^2 C_\theta}{\sqrt{1 + \left(\frac{S_\rho}{T_\theta}\right)^2}} \cdot \frac{S_\rho}{T_\theta} \quad (\text{B-44})$$

$$\dot{x}_o = -F \frac{V}{H} \frac{C_\rho^2 C_\theta}{\sqrt{1 + \left(\frac{S_\rho}{T_\theta}\right)^2}}$$

If we translate the film such that the image motion on the optical axis is 0, then this is tantamount to subtracting (B-44) from (B-42) and (B-43), yielding

$$\dot{y}_s = 0 \quad , \quad \Delta \dot{x} = \frac{V}{H} S_\rho C_\rho C_\theta \Delta x \quad (\text{B-45})$$

Let us now consider the zooming phenomenon.

UNCLASSIFIED

UNCLASSIFIED

Let

$$\Delta x_z = F \tan \alpha \quad (B-46)$$

where

Δx_z is the position on the image plane measured with respect to the optical axis

F is the camera focal length

α is the angular direction of the principal ray measured with respect to the optical axis.

If we change the focal length as a function of time (zooming) then the resultant image velocity is found by differentiating (B-46) or

$$\Delta \dot{x}_z = \dot{F} \tan \alpha \quad (B-47)$$

where

$\Delta \dot{x}_z$ is the image velocity caused by zooming

\dot{F} is the time rate of change of focal length.

Substituting (B-46) into (B-47) yields

$$\Delta \dot{x}_z = \frac{\dot{F}}{F} \Delta x \quad (B-48)$$

If the zooming is proper, then the image motion, caused by zooming, just cancels the residual image motion due to satellite travel, or

$$\Delta \dot{x} + \Delta \dot{x}_z = 0 \quad (B-49)$$

Substituting (B-45) and (B-48) into (B-49) yields

$$\frac{V}{H} S_\rho C_\rho C_\theta + \frac{\dot{F}}{F} = 0 \quad (B-50)$$

UNCLASSIFIED

UNCLASSIFIED

Solving the differential Equation (B-50) yields

$$F = F_o \exp\left(-\frac{V}{H} S_\rho C_\rho C_\theta t\right) \quad (\text{B-51})$$

where F_o is the focal length at time = 0.

Finally, the image motion at the optical axis that must be cancelled by film travel is found by substituting (B-51) into (B-44), yielding

$$\dot{y}_o = F_o \frac{V}{H} \frac{C_\rho^2 C_\theta}{\sqrt{1 + \left(\frac{S_\rho}{T_\theta}\right)^2}} \frac{S_\rho}{T_\theta} \exp\left(-\frac{V}{H} S_\rho C_\rho C_\theta t\right) \quad (\text{B-52})$$

$$\dot{x}_o = -F_o \frac{V}{H} \frac{C_\rho^2 C_\theta}{\sqrt{1 + \left(\frac{S_\rho}{T_\theta}\right)^2}} \exp\left(-\frac{V}{H} S_\rho C_\rho C_\theta t\right)$$

The total image motion at the image plane, thus will be the square root of the sum of the squares of Equations (B-52), i. e.,

$$V_{io} = \sqrt{\dot{y}_o^2 + \dot{x}_o^2} = F_o \frac{V}{H} C_\rho^2 C_\theta \exp\left(\frac{V}{H} S_\rho C_\rho C_\theta t\right) \quad (\text{B-53})$$

UNCLASSIFIED

UNCLASSIFIED

APPENDIX C

SOME ERROR ANALYSES AND DESIGN DETAILS FOR THE FORWARD
AND SIDE-OBLIQUE STRIP CAMERA

I. QUESTION

What must be the initial setup for the camera to have proper IMC?

Analysis

If the satellite, having a vertically oriented camera, is first rolled and then pitched to place the camera into position, then the image velocities in the focal plane are given by equations (B-16) and (B-17). From these equations we may determine the image motion on the optical axis, as

$$x_i = y_i = 0 \quad (C-1)$$

Substituting (C-1) into (B-16) and (B-17) yields

$$\begin{aligned} \dot{x}_i &= 0 \\ \dot{y}_i &= F \frac{V}{H} C_\rho^2 C_\theta \end{aligned} \quad (C-2)$$

From (C-2) we see that the image motions are restricted to the y_i axis. This, in turn, means that the mechanisms causing film travel for IMC purposes are already properly oriented.

Let us now consider slit orientation. From (B-39) we have the relation that the slit equation is given by

$$y = F \frac{C_\rho}{T_\theta \sqrt{1 + \left(\frac{S_\rho}{T_\theta}\right)^2}} \quad (C-3)$$

UNCLASSIFIED

UNCLASSIFIED

Solving (B-25) and (B-26) simultaneously for y yields

$$y = \frac{1}{\sqrt{1 + \left(\frac{S_p}{T_\theta}\right)^2}} \left(x_v + \frac{S_p}{T_\theta} y_v \right) \quad (C-4)$$

Eliminating y between (C-3) and (C-4) yields

$$F \frac{C_p}{T_\theta} = x_v + \frac{S_p}{T_\theta} y_v \quad (C-5)$$

Substituting (B-21) into (C-5) yields

$$y_i = -x_i \frac{T_\theta}{S_p} + F \frac{C_\theta - C_p}{S_p} \quad (C-6)$$

From (C-6) we find that the slope of the slit line is given by

$$-\frac{T_\theta}{S_p}$$

or

$$\tan \alpha = -\frac{\tan \theta}{\sin \rho} \quad (C-7)$$

where

- α is the rotation of the slit with respect to its position in vertical photography
- θ is satellite roll angle
- ρ is satellite pitch angle

UNCLASSIFIED

UNCLASSIFIED

If we make the following restrictions:

- a) Satellite roll is less than satellite pitch
- b) Roll and pitch can be as great as 45°

then the amount that the slit must be able to rotate is

$$\alpha = \pm \tan^{-1} \frac{\tan 45^\circ}{\sin 45^\circ} = \pm 55^\circ \quad (\text{C-8})$$

Conclusions

- 1) If the satellite is first rolled and then pitched into position, then no rotation of the film travel mechanism about the optical axis is required.
- 2) The slit must be able to rotate $\pm 55^\circ$ from nominal position.

II. QUESTION

How wide can the slit be for exposure purposes?

Analysis

The component of image motion perpendicular to the slit in the neighborhood of the optical axis is given by (B-31)

$$\dot{y}_o = \frac{1}{F} \frac{V}{H} S_\rho S_\theta \sqrt{1 + \left(\frac{S_\rho}{T_\theta}\right)^2} y_o^2 \quad (\text{C-9})$$

The variation in image motion in this neighborhood is given by

$$\Delta \dot{y}_o = \frac{d\dot{y}}{dy_o} \Delta y_o$$

or

$$\Delta \dot{y}_o = \frac{2}{F} \frac{V}{H} S_\rho S_\theta \sqrt{1 + \left(\frac{S_\rho}{T_\theta}\right)^2} y_o \Delta y_o \quad (\text{C-10})$$

UNCLASSIFIED

UNCLASSIFIED

The fractional error of image motion ϵ at the edge of the slit is given by

$$\epsilon = \frac{\Delta \dot{y}_o}{\dot{y}_o} \quad (C-11)$$

Substituting (C-9) and (C-10) into (C-11) yields

$$\Delta y = \frac{\epsilon y_o}{Z} \quad (C-12)$$

Substituting (B-35) into (C-12) yields

$$\Delta y = \frac{\epsilon F C \rho}{2 T \theta} \frac{1}{S^2 \left(1 + \frac{\rho}{T \theta} \right)} \quad (C-13)$$

The slit width is most restricted when the denominator is a maximum and the numerator is a minimum. This is equivalent to stating that the slit width is most restricted when both θ and ρ are maximum. Therefore let $\rho = \theta = 45^\circ$. Substituting these values into (C-13) yields

$$\Delta y = 0.29 \epsilon F \quad (C-14)$$

If we assume that $\epsilon = 10^{-3}$ and $F = 240$ inches then Δy is restricted to widths narrower than 0.07 inch.

$$\Delta y = 0.07 \text{ inch.} \quad (C-15)$$

UNCLASSIFIED

UNCLASSIFIED

Conclusions

If we allow pitch and roll to be as great as 45° , and we restrict image motions to vary less than 0.1% anywhere in the slit, then the maximum slit width for a 20 foot focal length camera is 0.07 inch.

III. QUESTION

What is the maximum allowed exposure time?

Analysis

The maximum allowed exposure time is given by

$$t_{\max} = \frac{\Delta y}{\dot{y}_0} \quad (C-16)$$

Substituting (B-35), (C-9), and (C-13) into (C-16) yields

$$t_{\max} = \frac{\epsilon}{2 \frac{V}{H} S_\rho C_\rho C_\theta} \quad (C-17)$$

Substituting the following values

$$\epsilon = 10^{-3}$$

$$\frac{V}{H} = 4 \times 10^{-2} \text{ at an altitude of 100 n mi}$$

$$\rho = \theta = 45^\circ$$

into (C-17) yields

$$t_{\max} = \frac{1}{14} \text{ sec.}$$

Conclusions

The camera must be designed so that the slit widths restrict exposure times to less than 1/14 second at 100 n mi. Further, maximum allowed exposure time is inversely proportional to V/H .

UNCLASSIFIED

UNCLASSIFIED

IV. QUESTION

What is the zoom rate and maximum ratio?

Analysis

Equation (B-51) gives the form of the zoom to be

$$F = F_o \exp\left(-\frac{V}{H} S_\rho C_\rho C_\theta t\right) \quad (C-18)$$

where F_o is the initial focal length

F is focal length at some time t

The total image motion in the image plane at the optical axis \dot{R}_o is given by the square root of the sums of the squares of equations (B-52) or

$$\dot{R}_o = \sqrt{\dot{y}_o^2 + \dot{x}_o^2}$$

or

$$\dot{R}_o = F_o \frac{V}{H} C_\rho^2 C_\theta \exp\left(-\frac{V}{H} S_\rho C_\rho C_\theta t\right) \quad (C-19)$$

The total length of the exposure R_o is given by the integral of (B-19)

$$R_o = \int_0^{t_{\max}} \dot{R}_o dt$$

or

$$R_o = \frac{F_o}{T_\rho} \left[1 - \exp\left(-\frac{V}{H} S_\rho C_\rho C_\theta t_{\max}\right) \right] \quad (C-20)$$

UNCLASSIFIED

UNCLASSIFIED

Since the exponent tends to be quite small, we may approximate

$$\exp\left(-\frac{V}{H} S_{\rho} C_{\rho} C_{\theta} t_{\max}\right) \approx 1 - \frac{V}{H} S_{\rho} C_{\rho} C_{\theta} t_{\max} \quad (C-21)$$

Substituting (C-21) into (C-20) yields

$$R_o = F_o \frac{V}{H} C_{\rho}^2 C_{\theta} t_{\max}$$

or

$$t_{\max} = \frac{R_o}{F_o \frac{V}{H} C_{\rho}^2 C_{\theta}} \quad (C-22)$$

Substituting (C-22) into (C-18) yields

$$F_{\min} = F_o \exp\left(-T_{\rho} \frac{R_o}{F_o}\right) \quad (C-23)$$

Expansion of the exponential into an infinite series yields

$$F_{\min} = F_o \left[1 - \frac{T_{\rho} R_o}{F_o} + \frac{1}{2} \left(\frac{T_{\rho} R_o}{F_o} \right)^2 - \frac{1}{6} \left(\frac{T_{\rho} R_o}{F_o} \right)^3 + \dots \right] \quad (C-24)$$

The servos will be reasonably simple if the fourth term in the series can be neglected. This is possible only if (for a 0.1% IMC system)

$$\frac{1}{6} \frac{T_{\rho}^3 R_o^3}{F_o^3} = 10^{-3} \quad (C-25)$$

UNCLASSIFIED

UNCLASSIFIED

or

$$R_o = 0.182 \frac{F_o}{T_\rho}$$

If we assume a focal length of 20 feet and a forward pitch angle of 45° then the frame length R_o can be 3.6 feet long when the camera is pitched 45° forward. It can be longer if the camera is pitched less.

Substituting (C-25) into (C-23) yields

$$\frac{F_{\min}}{F_o} = \exp - 0.182 = 0.834$$

This implies that the focal length will never have to decrease more than 17%.

Let us now determine the maximum rate of zoom that is required. Differentiating (C-18) yields

$$\frac{\dot{F}}{F_o} = - \frac{V}{H} S_\rho C_\rho C_\theta \left(\exp - \frac{V}{H} S_\rho C_\rho C_\theta t \right) \quad (C-26)$$

Inspection of (C-26) shows that the rate is maximum when

$\frac{V}{H}$ is maximum (0.04)

$$\rho = 45^\circ$$

$$\theta = 0$$

$$t = 0$$

Substituting these values into (C-26) shows that

$$\left(\frac{\dot{F}}{F_o} \right)_{\max} = 0.02$$

UNCLASSIFIED

UNCLASSIFIED

This result shows that the maximum possible zoom rate (as well as film speed change rate) under the worst conditions never exceeds 2% per second.

Conclusions

The analysis above shows that for a frame format at least 3.6 feet long the zoom rate never exceeds 2% per second. The maximum zoom never exceeds 17%. Longer frame formats are possible at the expense of an increase in maximum zoom and the introduction of some non-linearities in the zoom rate.

UNCLASSIFIED

UNCLASSIFIED

NRO APPROVED FOR
RELEASE 1 JULY 2015

APPENDIX D

PRELIMINARY DESIGN CONSIDERATION ON A HIGH ACCURACY
FILM DRIVE MECHANISM

1.0 INTRODUCTION

A parametric study and analysis was made to develop and evaluate a high accuracy mechanical film drive capable of permitting very high resolution photography when coupled to a nearly defraction limited lens system. The system was considered for performance in a space vehicle. Design consideration was given to four modes of operation:

- a. vertical
- b. side-oblique
- c. forward and backward-oblique
- d. forward and backward side-oblique

Two film drive systems were developed to accommodate for operational modes a, and a + c. Two optical configurations are suggested to solve mode b. The chosen optical solution for b can be used with either film drive in a final photo-optical system design.

2.0 VARIOUS FILM DRIVE DESIGN APPROACHES

A film drive capable of better than 0.1% accuracy is required in order to deliver maximum resolution with very long focal length lenses of nearly defraction limited design and to meet the system requirement of 0.1% IMC.

Lacking specific design parameters, the following criteria were assumed:

Assumptions:

Film

width: 12.5 in.
length: 100 to 1000 ft
thickness: 0.003 in.
weight: approx. 24 lb/1000 ft

UNCLASSIFIED

UNCLASSIFIED
[REDACTED]

Lens focal length: 25 ft
IMC speed (V): 4 to 8 inches per sec
Max. angular rate: 1-3/4 deg/sec total angular motion
($t = 6^\circ$)
Side motion (V_{ip}): 0.3 inch/sec max
Total translation or side motion: 0.50 in. (design for ± 0.5 in.)
Running time per frame: 6 seconds
Forward or backward obliquity angle: not to exceed 30 degrees

Design commenced with a rather orthodox but proven drive as shown in Figure D-1. The system consists of nine units positioned successively from film supply to film take-up. Power is applied to the film drive system at four different points; i. e., the supply metering roller, the platen drive motor, the take-up metering motor, and the film take-up reel motor. The film is kept under tension from supply to the metering rollers by a braking action at the supply reel. The platen drive motor provides speed control for the movement of the film across the slit at the appropriate speed.

Film tension between the two metering rollers should be held constant at about 3 to 5 pounds by constant tension springs (negator springs) in the two platen loopers. Tension between the metering rollers and the supply or take-up reel will vary from 1 to 10 pounds. The tension is controlled by a set of springs in the two tension loopers.

The four loopers in the system serve to provide smooth operation by controlling the film tension and help to keep the system in dynamic balance by activating and de-activating certain components in the system.

A more sophisticated design of a film and platen drive is suggested in Figure D-2. Here, power to the film drive is applied only in three points, one of the motors (in the film supply drum) being used also as a brake. The platen for the system of Figure D-2 is identical to the platen for the system of Figure D-1. The two loopers are coupled mechanically. A system of this type is more sensitive to 'banding' due to unevenness in film transport, but if

UNCLASSIFIED
[REDACTED]

UNCLASSIFIED

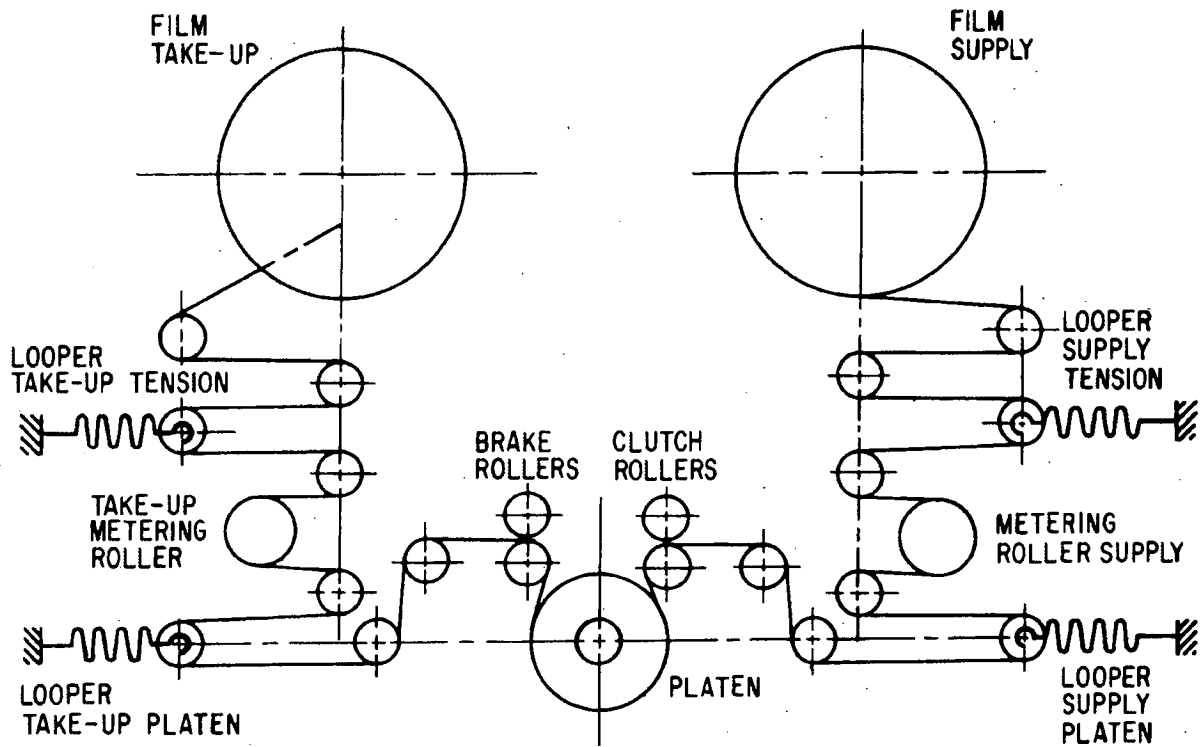

Figure D-1. Schematic of Film & Platen Drive for Conventional Aerial Camera

UNCLASSIFIED

UNCLASSIFIED

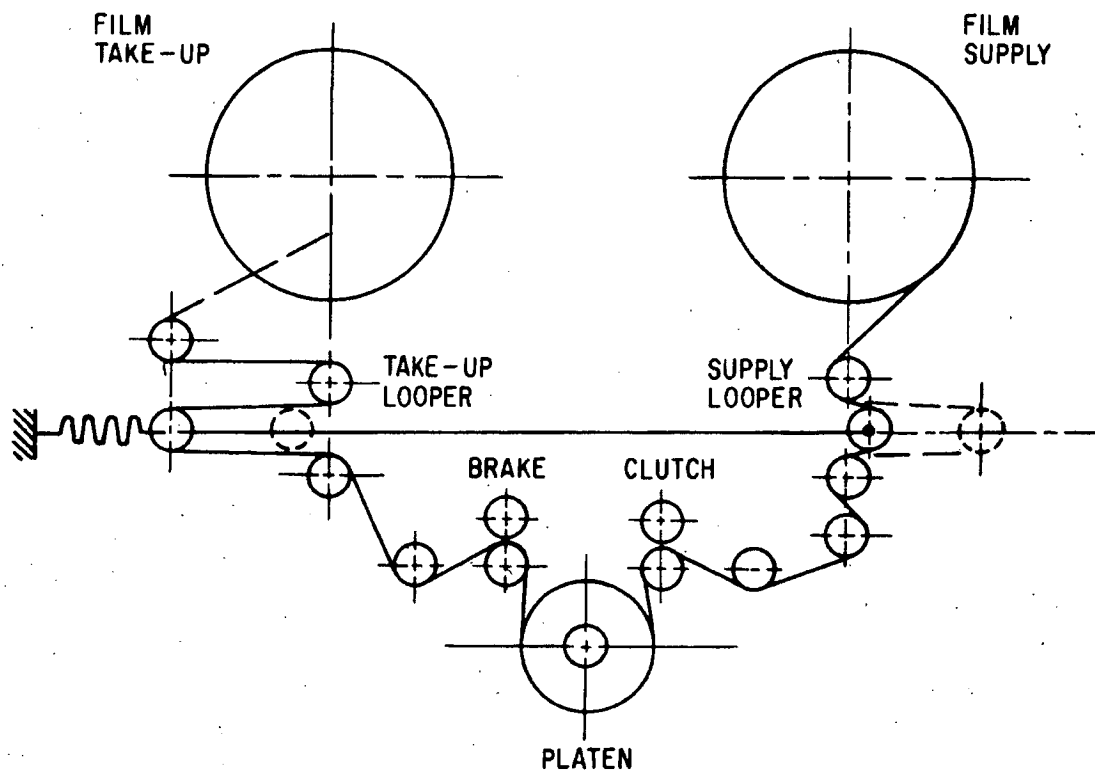

Figure D-2. Schematic of Film & Platen Drive for Advanced Aerial Camera

UNCLASSIFIED

UNCLASSIFIED

NRO APPROVED FOR
RELEASE 1 JULY 2015

carefully designed and built, should prove superior to the one in Figure D-1. Film tension throughout the system would be approximately the same as in the Figure D-1 system. Operation would be as follows:

On a given command a d-c voltage is supplied to the take-up reel motor. An a-c voltage is supplied to the film supply reel and the platen. Both are synchronous motors with variable frequency speed control. The motor on the film supply reel is also used as a brake to control the momentum of the film supply reel. A hysteresis clutch in the film take-up drive permits variable slippage in the drive to compensate for the varying diameter of the take-up reel. Both reels also have locking brakes which are engaged when power is off to prevent the reels from turning and to retain film tension in the system during "off" periods. The film tension maintained in Figure D-2 will vary from approximately 1 pound when the supply looper is full, to 6 to 8 pounds with the supply looper empty. Hysteresis brake torque will vary accordingly from about 8 foot pounds to zero with about 3 foot pounds at midposition.

Figure D-3 shows a possible first design approach to the rotary platen problem. Besides a variable IMC speed, Y motion controlled by an adjustable cam and Z adjust are provided. Rotation of the total system is shown in two places, one for gross adjust and one for programmed motion.

Figure D-4 is a further development of the design approach shown in Figure D-3. Only a single system rotation plane is provided and the Z adjust has been eliminated. The drum is rim driven rather than through gears to eliminate vibration.

The Film Flow Schematic of Figure D-5 is similar to the one shown in Figure D-2. Wobble rollers as well as clutch and brake rollers were added to permit side and rotary motion of the film drive independent of the film supply and take-up which could then be located outside the camera proper.

The design shown by Figure D-6 was developed after an engineering review of Figures D-1 through D-5, with emphasis given to the possibility of short duration missions where perhaps only a hundred feet or so of film would be required per mission experiment. In this design a new approach to the take-up

UNCLASSIFIED

UNCLASSIFIED

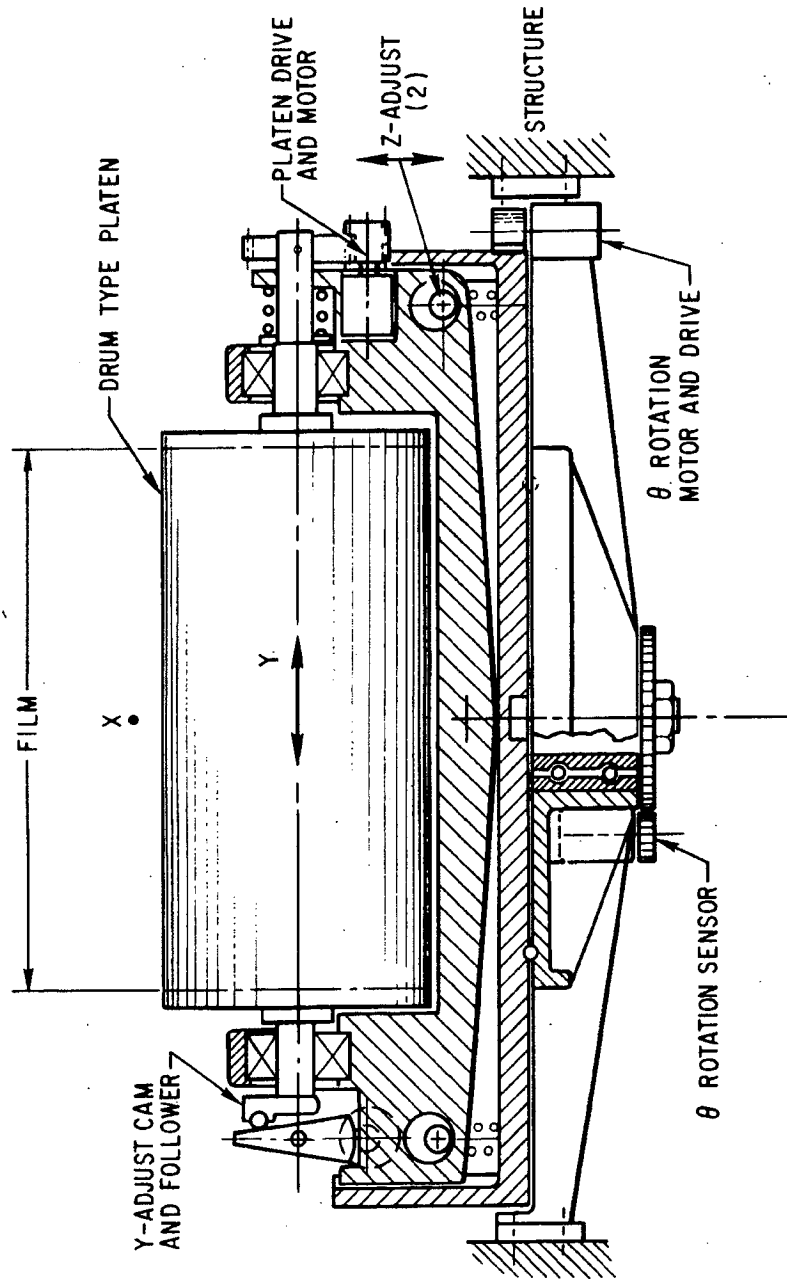

Figure D-3. Schematic of Film Drive Platen

UNCLASSIFIED

UNCLASSIFIED

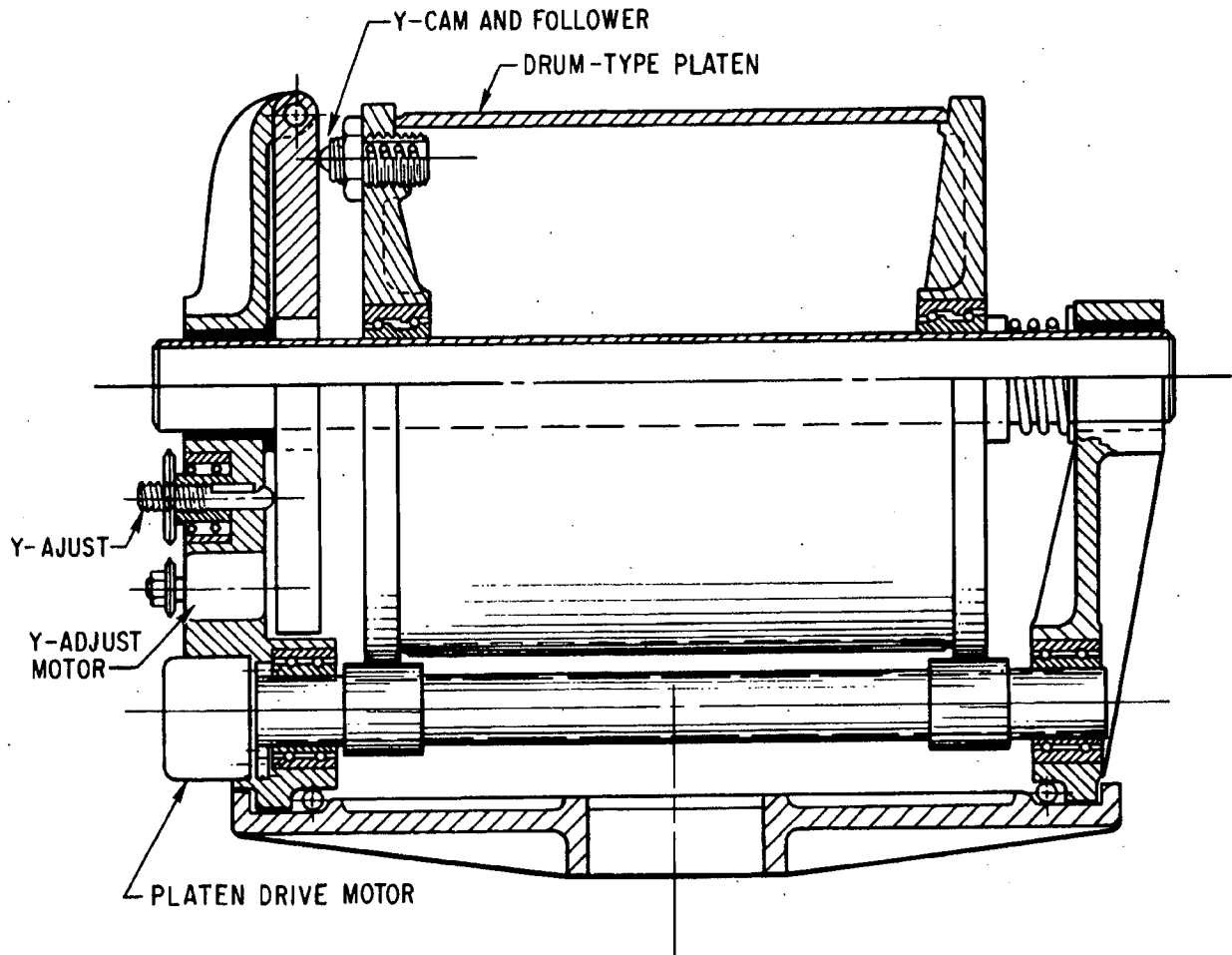

Figure D-4. Schematic of Design Variation of Film Drive Platen

D-7
UNCLASSIFIED

UNCLASSIFIED

Revised 4 Nov 1965

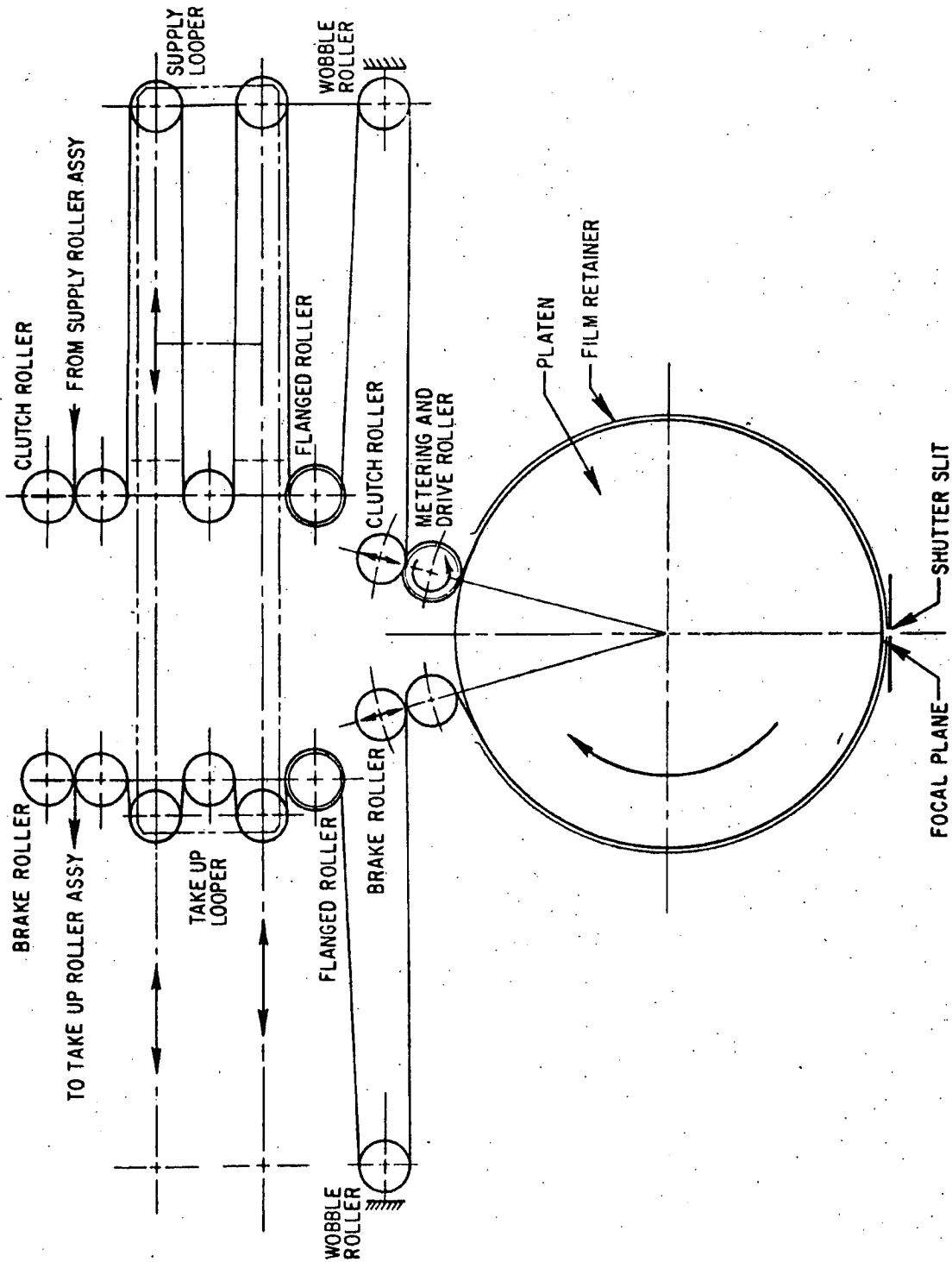

Figure D-5. Schematic of Slit Camera Film Flow

UNCLASSIFIED

UNCLASSIFIED

NRO APPROVED FOR
RELEASE 1 JULY 2015

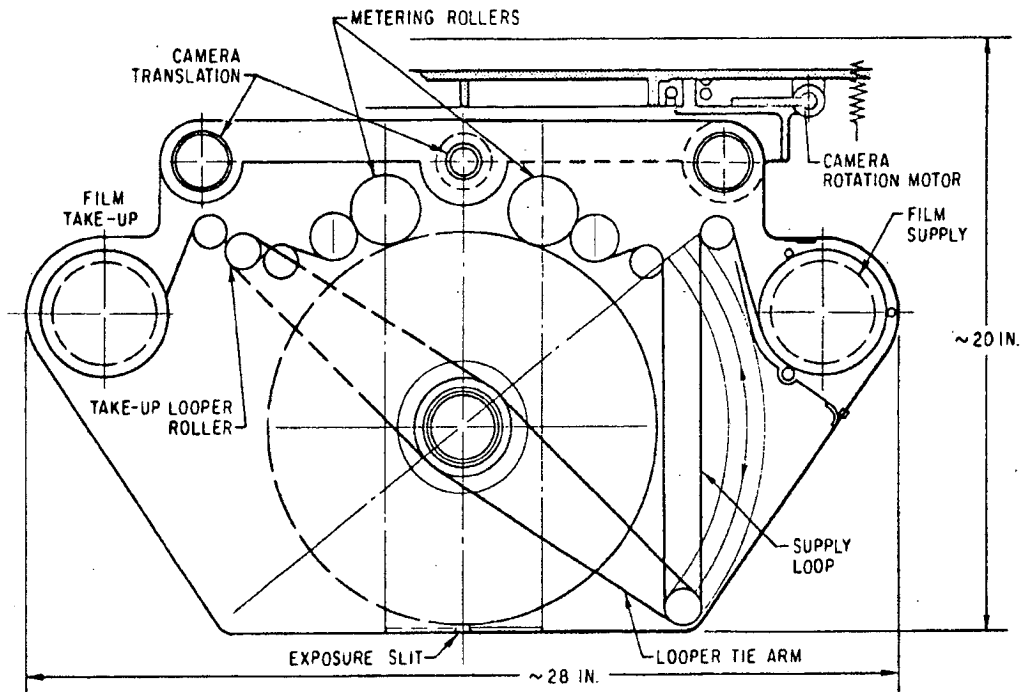
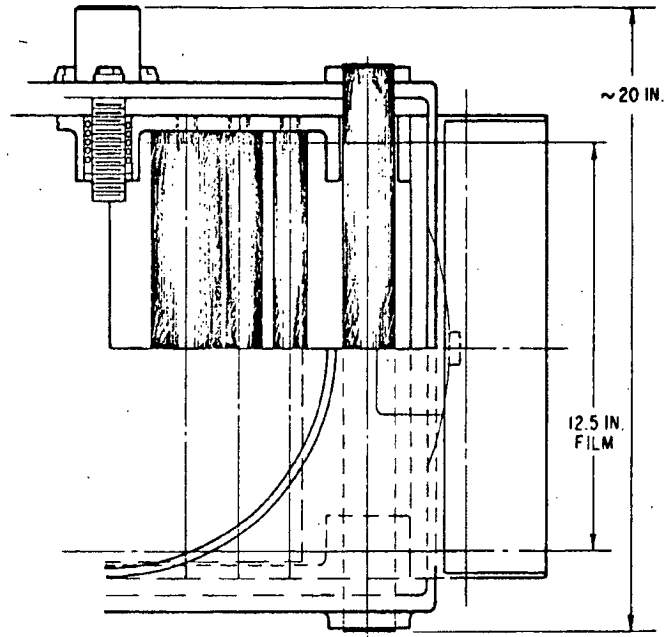

Figure D-6. Schematic of a Compact Design Film Drive Rotary Platen

UNCLASSIFIED

UNCLASSIFIED

looper has been made. This new design and the reduced film roll size make for a rather compact and clean design. This study also brought out the possible need for a rotating slit in the camera should side-oblique photography be attempted.

Figure D-7 represents a design concept for such a film drive camera body. Note that the rotating platen has been abandoned and its place is taken by a slit-platen combination that has minimum contact with the film and can be rotated through ± 45 degrees. A design of this type would present a real engineering challenge. The relatively long stretch of unsupported film in the focal plane area, running at considerable IMC speed, would be difficult to keep from oscillating and precise flatness in the focal plane would be most difficult to maintain. These considerations prompted the development of a new drive concept in which a belt-loop is employed as a constant film speed drive medium (Figures D-8 and D-9) and/or as a film support and transport medium (Figure D-10).

Figures D-8 and D-9 show variation of the drive belt integration into a film transport system. Only a single motor is needed for such a transport design but difficulties such as film spill from a full supply roll could be encountered when the drive is stopped too fast. A separate brake on the film supply spool might be needed.

Figure D-10 elaborates on the belt-drive idea extending the drive to carrying the film in a conveyor-like fashion over a platen and by the exposure slit. A system of this kind would do very well in an earth environment and could also be used in a framing camera system. The drive-film transport belt might be made of a porous material that would permit a vacuum application to the film to hold it flat in the focal plane.

Figures D-11 and D-12 show the application of the constant film velocity drive to a rotating platen slit camera. Such a design approach would possibly prove equal to or better than the more sophisticated drive designs if the camera

UNCLASSIFIED

UNCLASSIFIED

NRO APPROVED FOR
RELEASE 1 JULY 2015

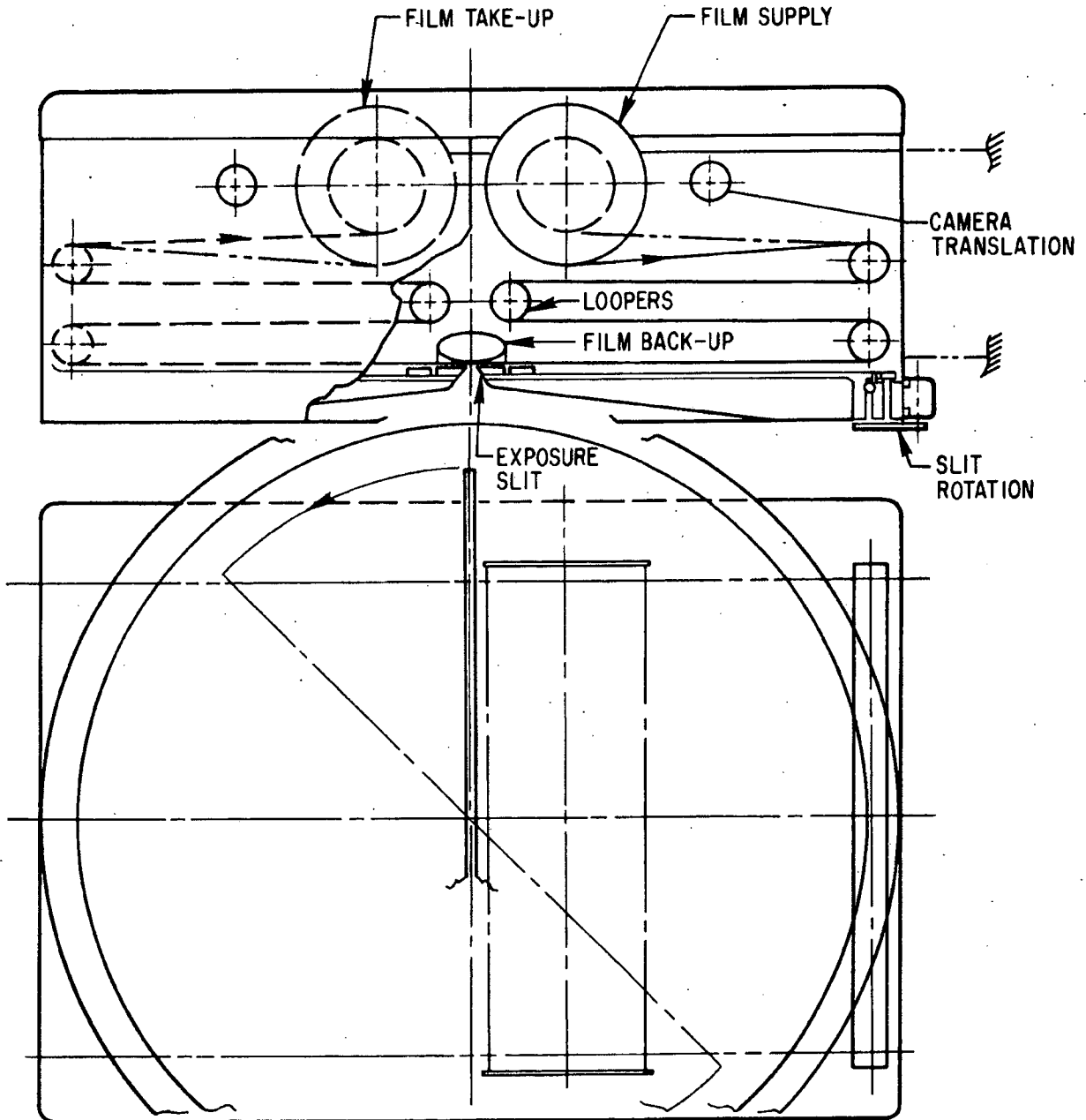

Figure D-7. Schematic of a Compact Design Slit Camera Film Drive Employing a Rotating Slit Plate & Film Back-up at Focal Plane

UNCLASSIFIED

UNCLASSIFIED

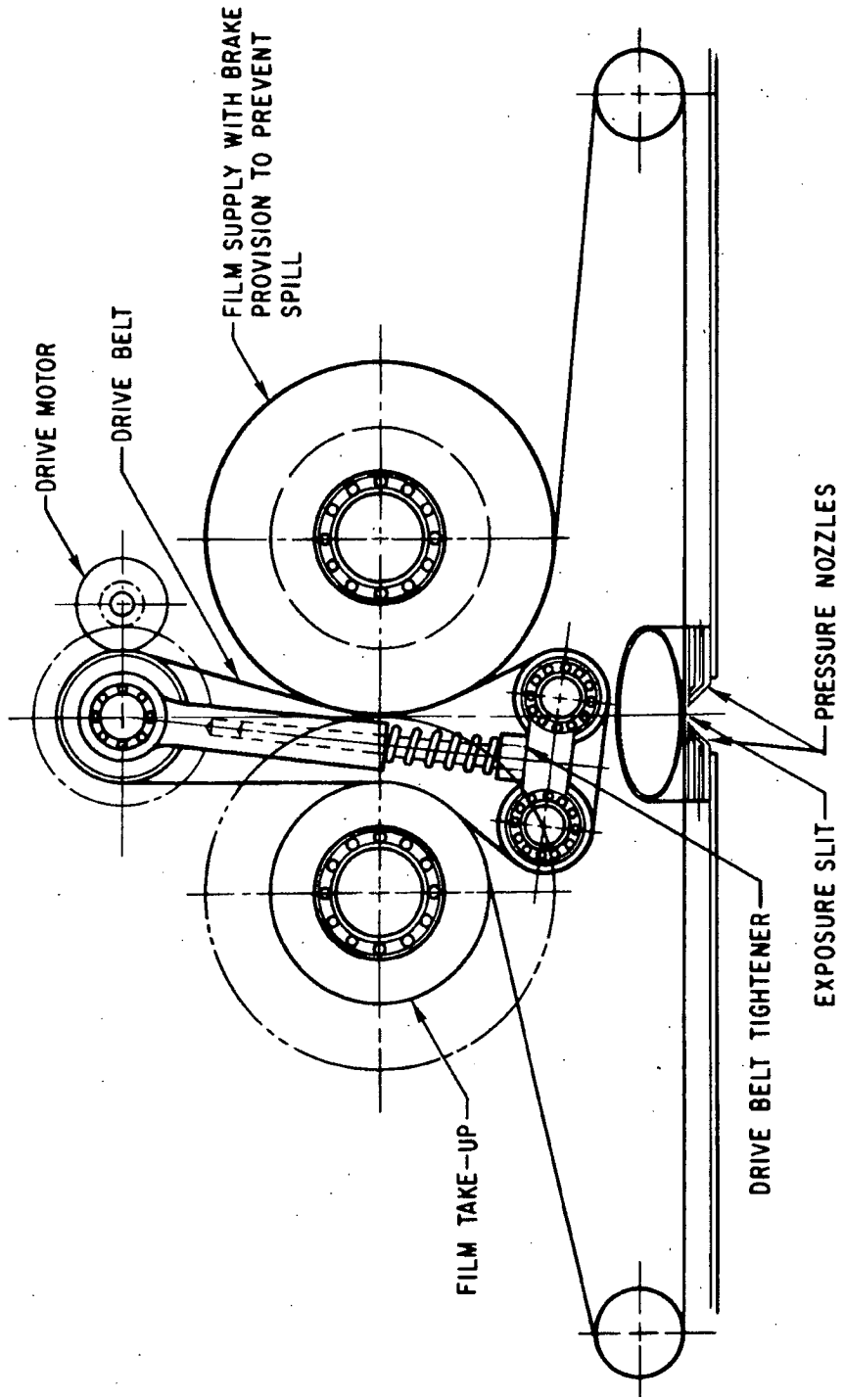

Figure D-8. Schematic of a Constant Speed Film Drive

UNCLASSIFIED

UNCLASSIFIED

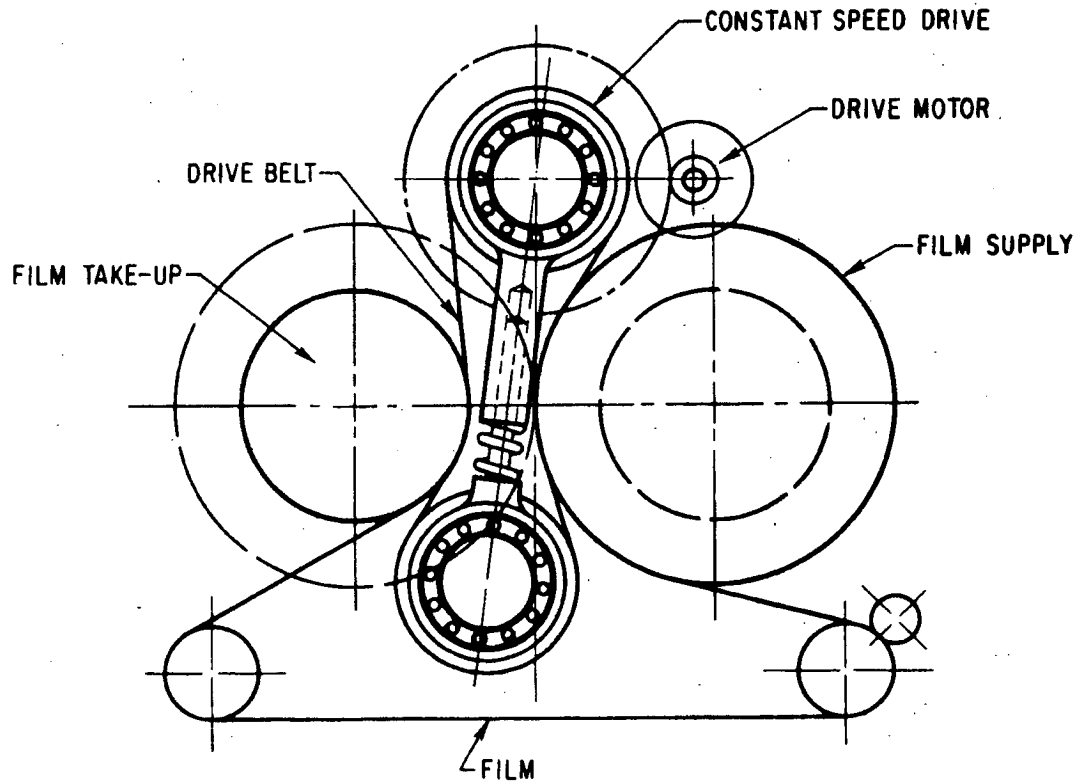

Figure D-9. Schematic of a Variation of a Constant Speed Film Drive

UNCLASSIFIED

UNCLASSIFIED

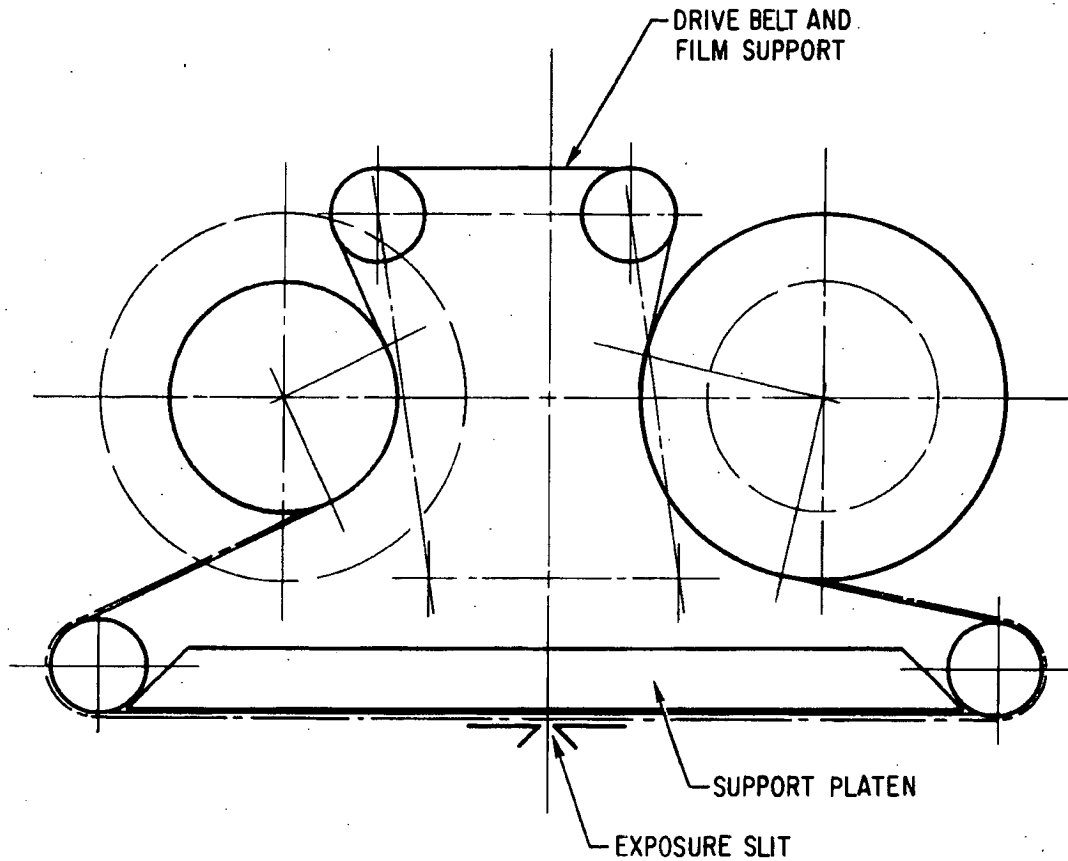

Figure D-10. Schematic of Constant Speed Film Drive Employing a Drive-Film Support Belt in a Slit Camera

D-14
UNCLASSIFIED

UNCLASSIFIED

NRO APPROVED FOR
RELEASE 1 JULY 2015

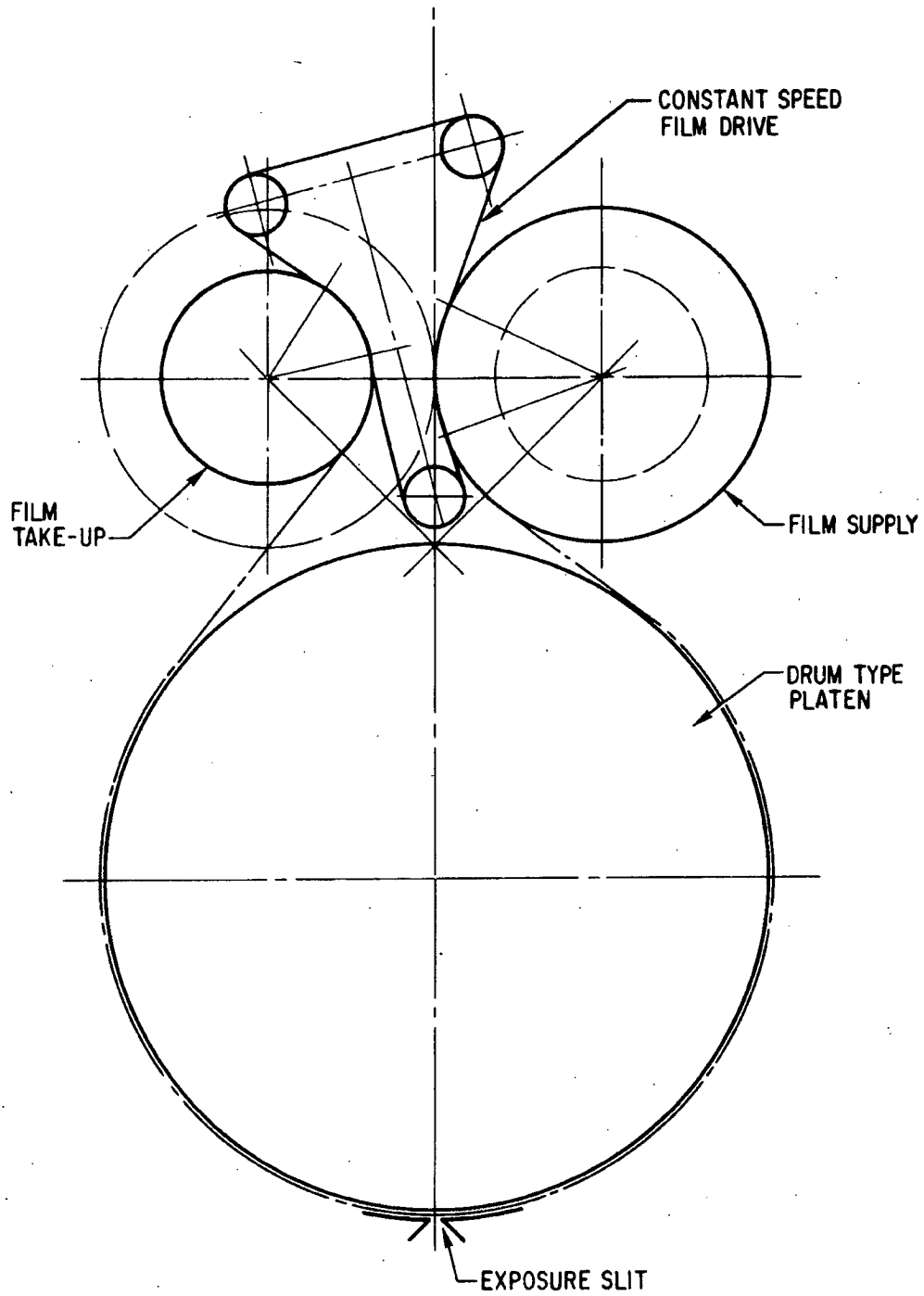

Figure D-11. Schematic of Constant Speed Drive in Rotating Platen Camera

UNCLASSIFIED

UNCLASSIFIED

NRO APPROVED FOR
RELEASE 1 JULY 2015

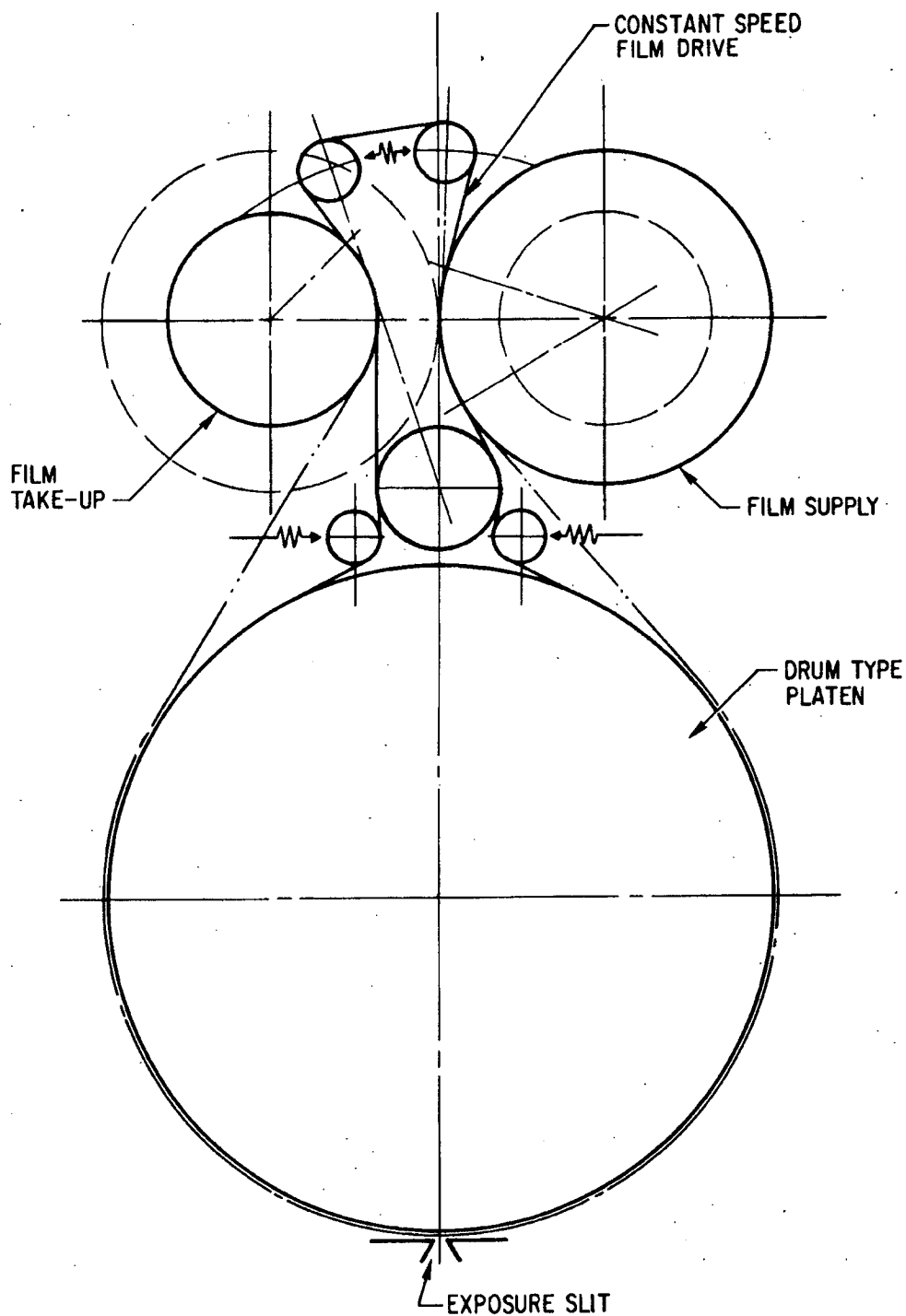

Figure D-12. Schematic of Design Variation of Constant Speed Drive in Rotating Platen Camera

UNCLASSIFIED

UNCLASSIFIED

drive could run continuously.- The design might become marginal in a stop and go application because of the large mass acceleration and deceleration with possible spilling of film, etc.

Figures D-13 and D-14 sum up schematically the two film drive approaches considered feasible. Figure D-13 would be the more orthodox and proven design, but is incapable of coping with the forward side-oblique situation.

Figure D-14 will require considerable engineering R&D, but once solved could be used in many applications. The need for holding the film flat in the gate is obvious, as is the control of vibrations, drag, etc. Considerations of these problems led to the design Figure D-15. In this camera configuration a separate dampened film support belt is used in conjunction with a closed loop vacuum/pressure system at the focal plane. The exposure slit and camera can rotate about the optical axis while the whole system is capable of translating sideways. Figure D-16 shows a possible solution for a drum-slit system design along the lines previously discussed. As mentioned before, the design is considerably more orthodox than the one shown in Figure D-15. Considerable design complexity could be avoided if the forward side-oblique case is not a requirement.

The IMC problem resulting from forward and back-oblique photography can be solved by the introduction of a re-imaging system and by purely mechanically moving a number of mirrors to lengthen or shorten the light paths. A preferable approach would employ a re-imaging system designed to zoom the appropriate amount during exposure. Figure D-17 shows the two approaches schematically and Figure D-18 shows a schematic of the lens system employed.

3.0 CAMERA DESIGN

3.1 FILM DRIVE CONSIDERATIONS - SUMMARY

A progression of film drive designs was investigated in an attempt to determine an optimum design which would meet the high accuracy requirement of this system. As a result of these analyses two design approaches are

UNCLASSIFIED

UNCLASSIFIED

Revised 4 Nov 1965

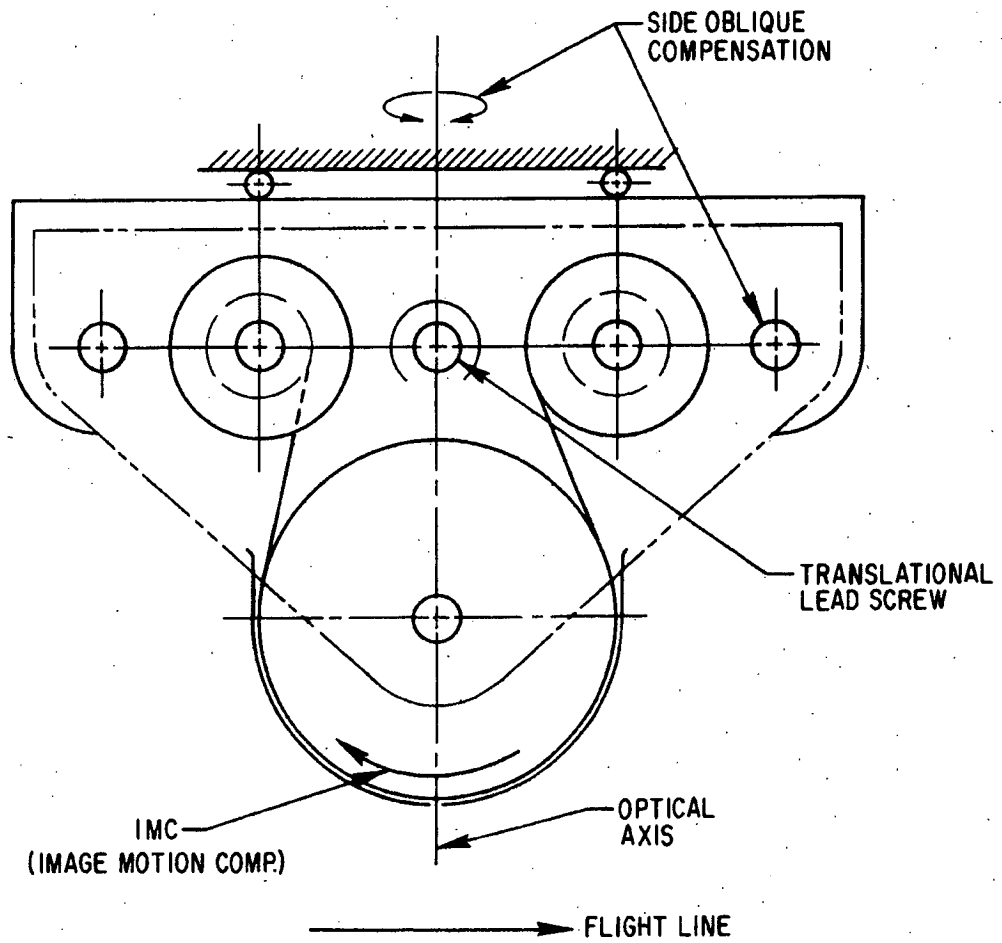

Figure D-13. Film Transport System for Vertical or Side-Oblique Photography Employing a Drum-type Platen

UNCLASSIFIED

UNCLASSIFIED

Revised 4 Nov 1965

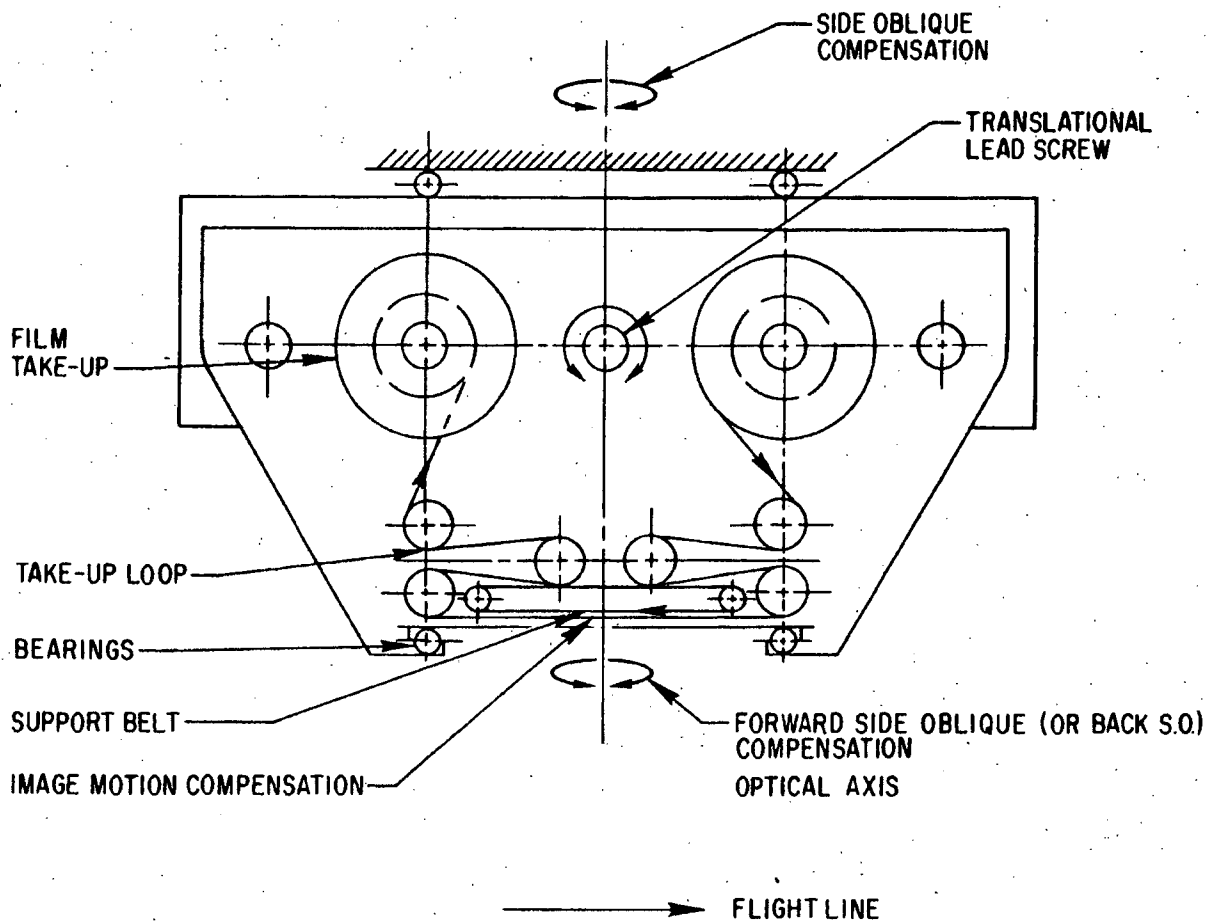

Figure D-14. Schematic of Film Drive Employing Rotating Exposure Slit Plate & Film Support Belt at Focal Plane

UNCLASSIFIED

UNCLASSIFIED

Revised 4 Nov 1965

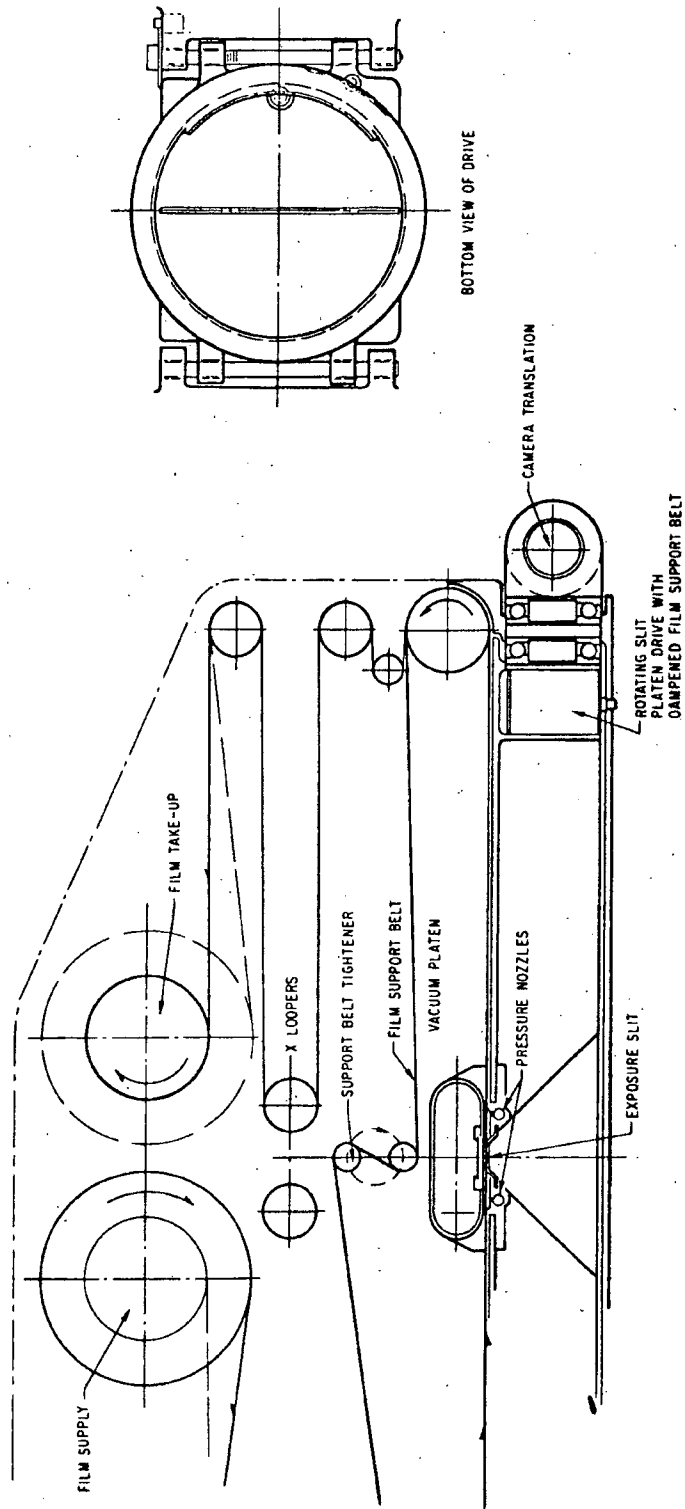

Figure D-15. Preliminary Design for a Film Drive Employing a Closed Loop Vacuum System & Rotating Slit Platen at Focal Plane

UNCLASSIFIED

UNCLASSIFIED

ATTACHMENT TO FIGURE D-15

Film Width: 12.5 in.
Film Thickness: 0.0053 in. (SO-243) or 0.0025 in. (4404)
Film Core Dim.
& Weights: a) Universal Aerial Film Core/Flanges
Core dia.: 4.25 in. (0.125 in. thick Mg)
Flange Dia.: 8.0 in. (0.295 in. Al)
Spool will hold 500 ft of SO-243 (19.5 lb)
1000 ft of 4404 (23 lb)
Empty spool will weight approx. 3.5 lb each
b) Spool-Aerial Roll Film (USAF 51C17848)
Core dia. 2.12 in. (Al 1/16 in. thick)
Flange dia. 4.12 in. for 100 ft (0.005 film)
5.94 in. for 250 ft (0.005 film)
Note: The 4.12 reel will take ~ 300 ft and the 5.94
reel take ~ 700 ft of 0.0025 film.
Weight of spool empty: 0.75 lb and 1.00 lb
Weight with 0.0053 film, 100 ft - 4.6 lb, 250 ft - 10.6 lb
Weight with 0.0025 film, 300 ft - 7.65 lb, 700 ft - 16.5 lb

Film Belt: Width: 13 inches
Thickness: ~ 0.06 in.
Weight: ~ 0.30 lb/ft = 1.25 lb
Running speed: 4 to 8 in./sec

Film Drive: Drive rollers (2): 1.5 in. dia., ~ 66 - 132 RPM, 1 lb each
Film slit mech. weight: ~ 10 lb
Film drive, total, exclusive of film: ~ 65 lb
Note: This is the assumed total weight of the mechanism to
be translated and rotated.

UNCLASSIFIED

UNCLASSIFIED

Revised 4 Nov 1965

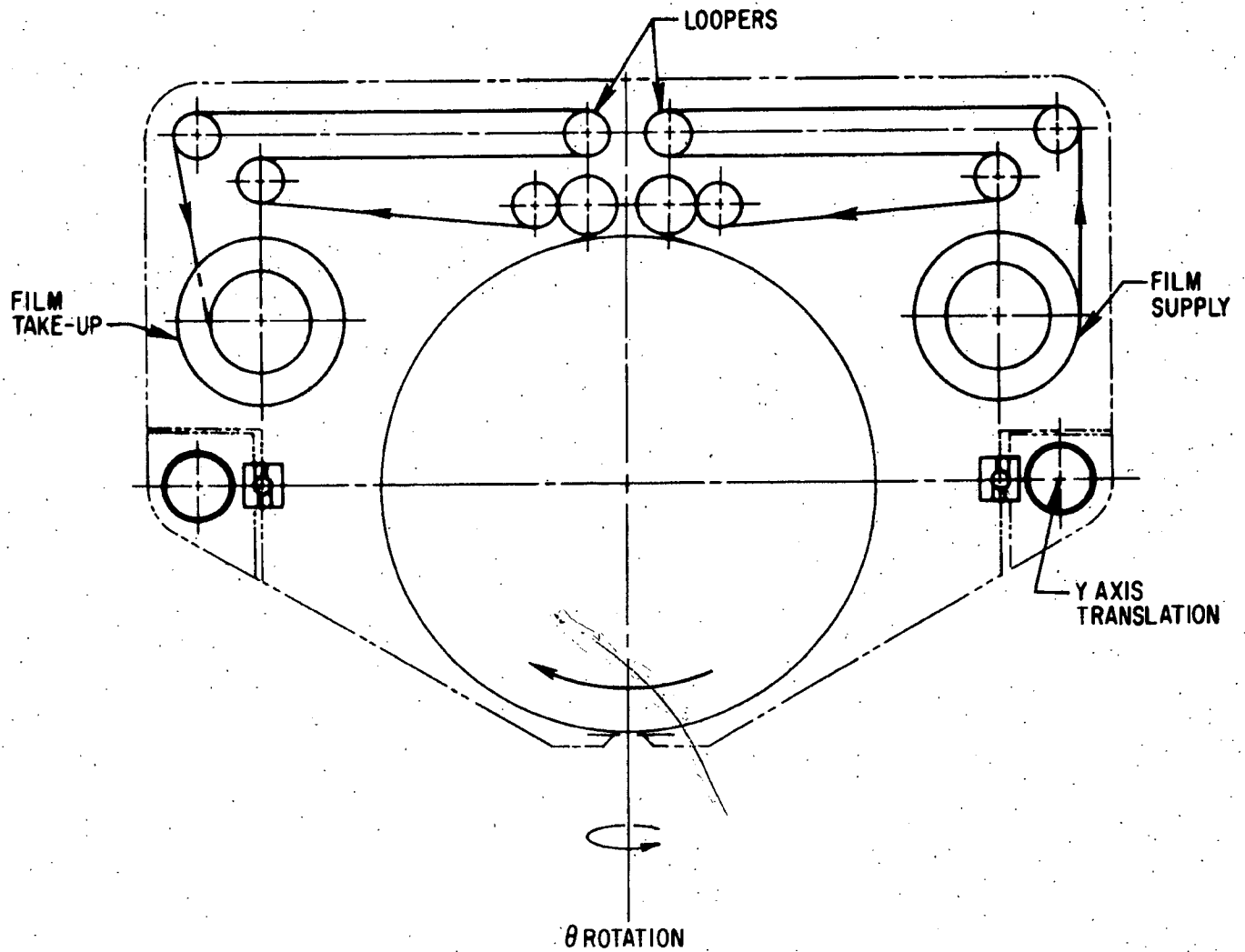

Figure D-16. Schematic of Rotary Drum Film Drive Providing Freedom in Y Axis and Rotation above ϕ (θ)

UNCLASSIFIED

UNCLASSIFIED

ATTACHMENT TO FIGURE D-16

Film Width: 12.5 inches

Film Thickness: 0.0053 in. (SO-243 or 0.0025 in.) (4404)

Film Core Dim.

& Weights:

- a) Universal Aerial Film Core/Flanges
Core dia.: 4.25 in. (0.125 in. thick Mg)
Flange dia.: 8.0 in. (0.295 in. Al)
Spool will hold 500 feet of SO-243 (19.5 lb)
1000 feet of 4404 (23 lb)
Empty spool will weigh approx. 3.5 lb each

- b) Spool-Aerial Roll Film (USAF 51C17848)
Core dia.: 2.12 in. (Al 1/16 in. thick)
Flange dia.: 4.12 in. for 100 ft (0.005 film)
5.94 in. for 250 ft (0.005 film)

Note: The 4.12 reel will take ~ 300 ft and the 5.94
reel take ~ 700 ft of 0.0025 film.

Weight of spool empty: 0.75 lb and 1.00 lb

Weight with 0.0053 film, 100 ft - 4.6 lb, 250 ft - 10.6 lb

Weight with 0.0025 film, 300 ft - 7.65 lb, 700 ft - 16.5 lb

Drum Dimensions

& Weight:

12 in. dia x 13 in. long

rotation approx. 6 RPM to 13 RPM

weight approx. 10 lb (skin ~ 7 lb)

Camera weight without film: about 55 lb

Drive rollers: approx. 1 lb each

rotation about 60 - 120 RPM

UNCLASSIFIED

UNCLASSIFIED

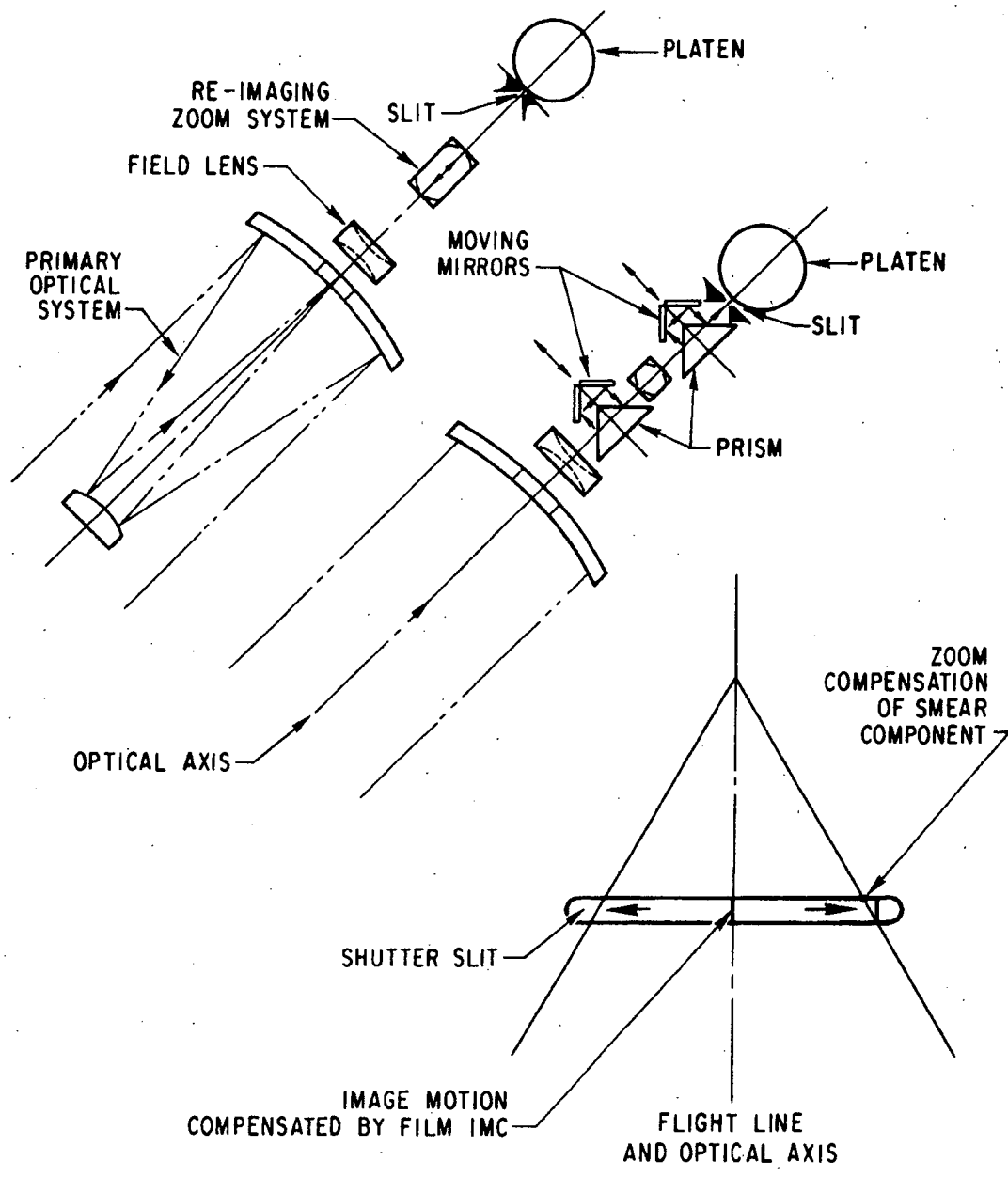
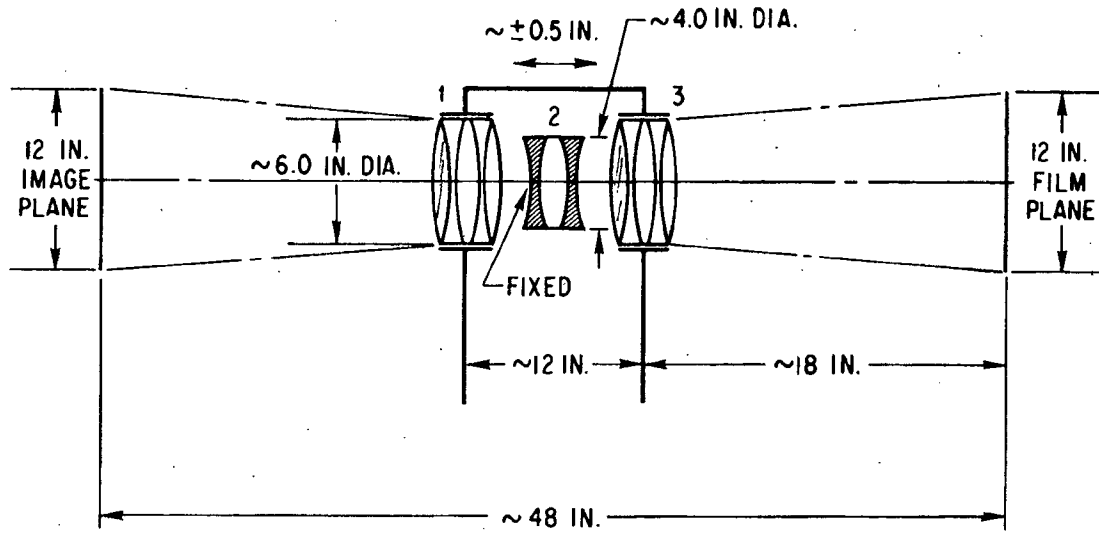

Figure D-17. Re-Imaging System Schematic for Forward and Backward Oblique Photography

D-24
UNCLASSIFIED

UNCLASSIFIED



TOTAL WEIGHT: ~15 LB
WEIGHT OF MOV. COMP: ~12 LB

Figure D-18. Schematic of Zoom Re-Imaging Lens System to Compensate for Forward and Backward Oblique Photography

D-25
UNCLASSIFIED

UNCLASSIFIED

ATTACHMENT TO FIGURE D-18

Weight & Design: Total weight: approx. 15 to 18 lb
Weight of moving comp: ~ 12 lb
Maximum total motion: ~ 0.60 in. assuming: 0.20 in./sec
(total duration 3 sec).

Note: It was assumed that only one forward and/or backward-oblique angle will be considered for stereo photography as it will be most difficult to sense the continuous change in focal length of the re-imaging lens and to drive the film accordingly at a continuously changing IMC rate to an accuracy better than 1/10 of one percent.

D-26
UNCLASSIFIED

UNCLASSIFIED

suggested which are believed to be within the realm of feasibility. A slit type camera appears to be the only choice for a non-camera tracking system. If only vertical or side-oblique photography is required, a more-or-less conventional drive system using a rotating drum platen may be employed. The accuracies which are sought are believed feasible, but extremely difficult to achieve. Figure D-19 shows such a system schematically.

Forward and backward plus side-oblique photography is of interest only if stereo photography is a requirement. Because of the necessity to rotate the slit at the focal plane, depending upon the obliquity angle, it is not feasible to employ a rotating drum platen. It might be possible to devise a belt backup drive system which could be held within the depth of focus tolerances. Such a system is shown schematically in Figure D-20. To fully compensate for the image motion, a zoom operation is required. This can most easily be accomplished as a re-imaging zoom system. The maximum zoom range for a four foot frame length was found to be less than 20%.

4. CONCLUSION

In conclusion it can be said that preliminary engineering considerations indicate the feasibility to design and build a camera film drive capable of moving film at the proper IMC speed and compensating for the error components due to any line-of-sight obliquity. It is questionable that the goal of a total error of 0.1% or better can be achieved without considerable R&D, as well as prototype design and performance evaluation of a number of systems.

UNCLASSIFIED

UNCLASSIFIED



Revised 4 Nov 1965

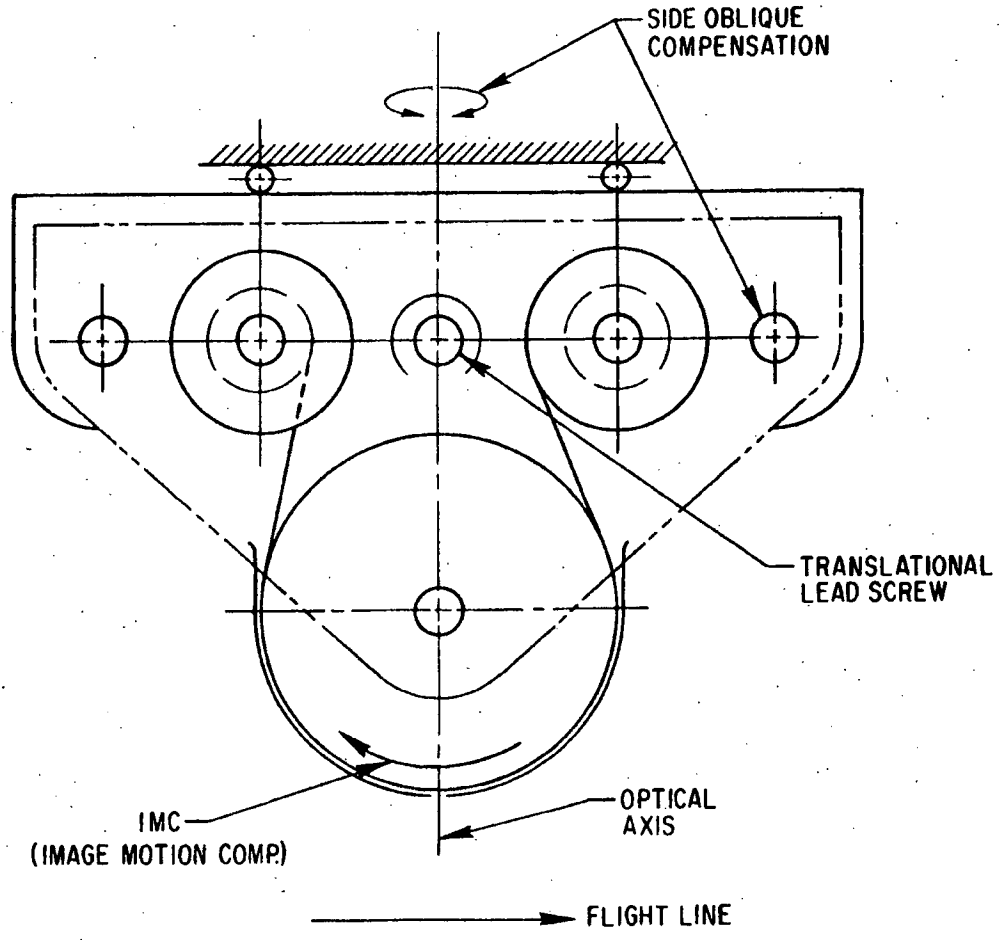

Figure D-19. Film Transport System for Vertical or Side-Oblique Photography Employing a Drum-type Platen

UNCLASSIFIED

D-28



UNCLASSIFIED

Revised 4 Nov 1965

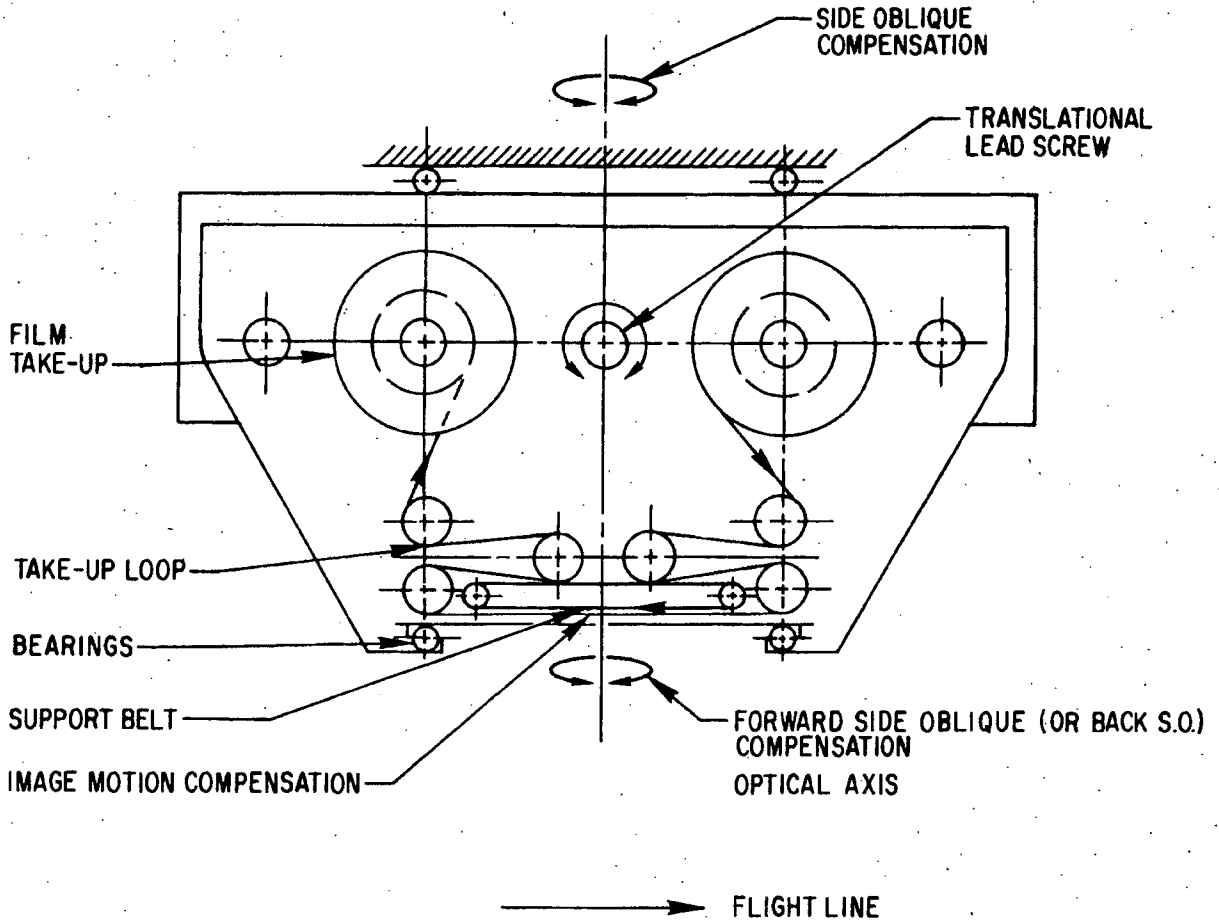

Figure D-20. Schematic of Film Drive Employing Rotating Exposure Slit Plate & Film Support Belt at Focal Plane

UNCLASSIFIED

D-29

AEROSPACE CORPORATION

TECHNICAL REPORTS - DISTRIBUTION LIST

REPORT TITLE

An Analysis of the Requirements for Very high
Accuracy Image Motion Compensation

REPORT NO.

TOR 669(6107-40)-1

DATE

October 1965

SECURITY CATEGORY

[REDACTED]

INTERNAL DISTRIBUTION

UNCLASSIFIED

- E. Alexander
- H. Bernstein
- J. Delangre
- F. Froom
- D. Giesecking
- R. Grove
- L. Hirschl
- F. Keller
- A. Mandl
- D. Martin
- D. Meronek
- D. McColl
- A. Nash
- J. Nilles (2)
- H. Nordyke
- W. Sampson
- C. Sarture
- E. Silvertooth
- S. Tennant
- J. Thompson
- J. Travis
- R. Kardas
- L. Watson

PREPARED BY

[Handwritten Signature]

AEROSPACE CORPORATION

TECHNICAL REPORTS - DISTRIBUTION LIST

REPORT TITLE

An Analysis of the Requirements for Very High
Accuracy Image Motion Compensation

REPORT NO.

TOR 669(6107-40)-1

DATE

October 1965

SECURITY CATEGORY

[REDACTED]

EXTERNAL DISTRIBUTION

UNCLASSIFIED

MILITARY AND GOVERNMENT OFFICES

ASSOCIATE CONTRACTORS AND OTHER

Air Force

Mr. L. C. Block

Wright Patterson Air Force Base
ASD, Air Force Avionics Laboratory

H. R. Mestwerdt, AVRP 20133

L. W. Crouch, AVRP 29136

F. A. Farinet, AVRP 20133

INSTRUCTIONS

WHEN APPROVED BY GOVERN-
MENT PROGRAM OFFICE, LINE
OUT UNUSED SPACE TO PRE-
CLUDE ADDITIONAL ENTRIES.

PREPARED BY

[Signature]

(FOR AEROSPACE CORPORATION)

APPROVED BY

[Signature]

(FOR GOVERNMENT PROGRAM OFFICE)

UNCLASSIFIED

*NRO APPROVED FOR
RELEASE 1 JULY 2015

AEROSPACE CORPORATION
DOCUMENT CHANGE NOTICE

A65 11232

TO: Copyholder
Aerospace TOR-669(6107-40)-1

DATE: 4 Nov 1965

SUBJECT: Errata Pages

FROM: Aerospace Publications

Attached are revised pages to Aerospace TOR-669(6107-40)-1, "An Analysis of the Requirements for Very High Accuracy Image Motion Compensation," dated October 1965. These pages should be inserted and supersede the pages revised, which should be removed and destroyed per applicable security regulations.

Aerospace copyholders should DOCIN the revised pages (AS-65-0000-04815) into the above report (AS-65-0000-03578) per Company Practice 6-40-3.

A65 11232

Classification of this document
will be downgraded to
UNCLASSIFIED upon removal
of Enclosures.

GROUP-4.

Downgraded at 3-year intervals;
declassified after 12 years.

UNCLASSIFIED

CLASSIFICATION CHANGED TO

AUTHORITY OF Ad
DATE Chann 2-13-69

UNCLASSIFIED

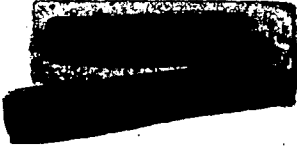

Revised 4 Nov 1965

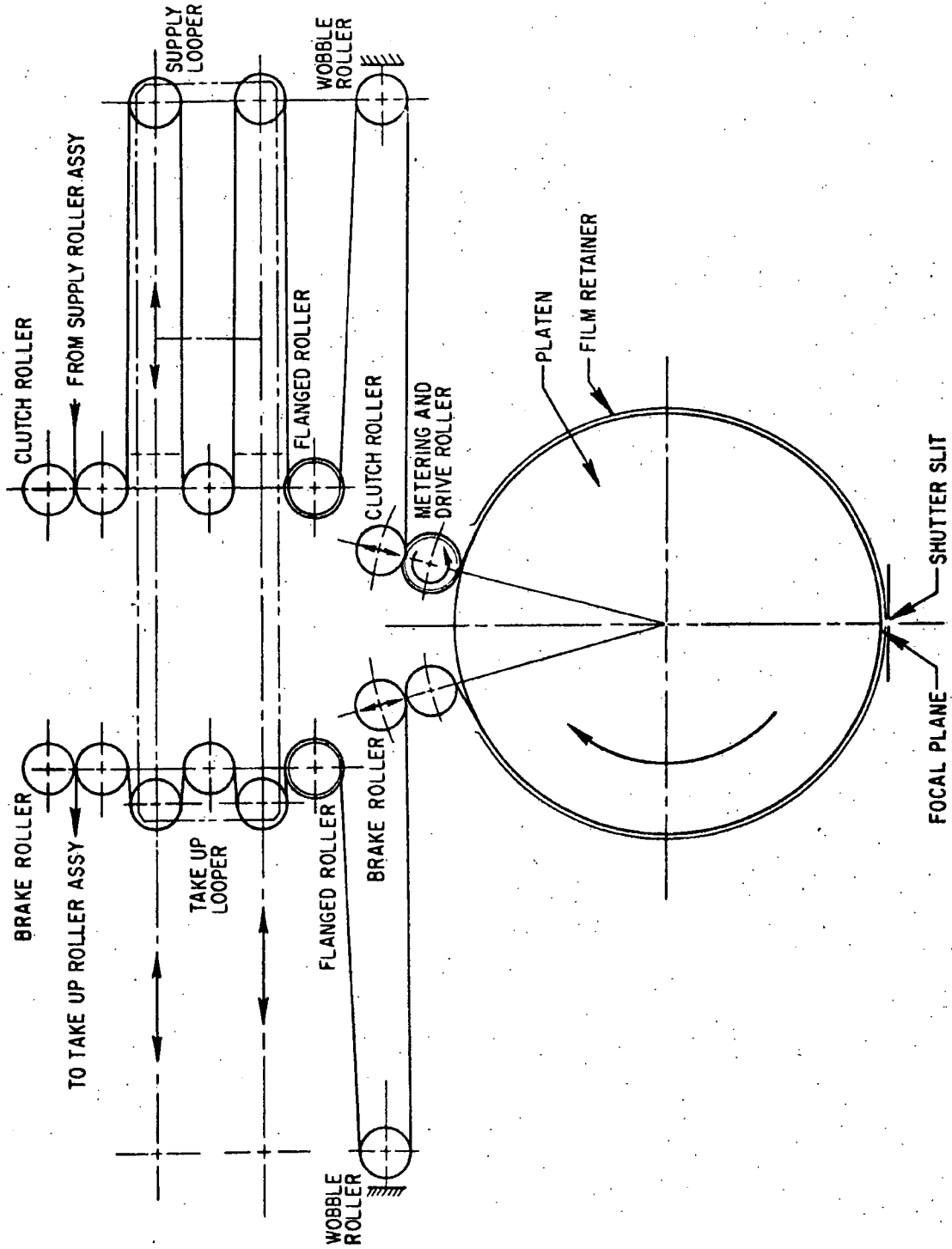

Figure D-5. Schematic of Slit Camera Film Flow

UNCLASSIFIED

D-8



UNCLASSIFIED

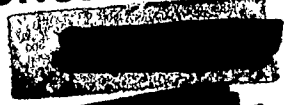

NRO APPROVED FOR
RELEASE 1 JULY 2015

Revised 4 Nov 1965

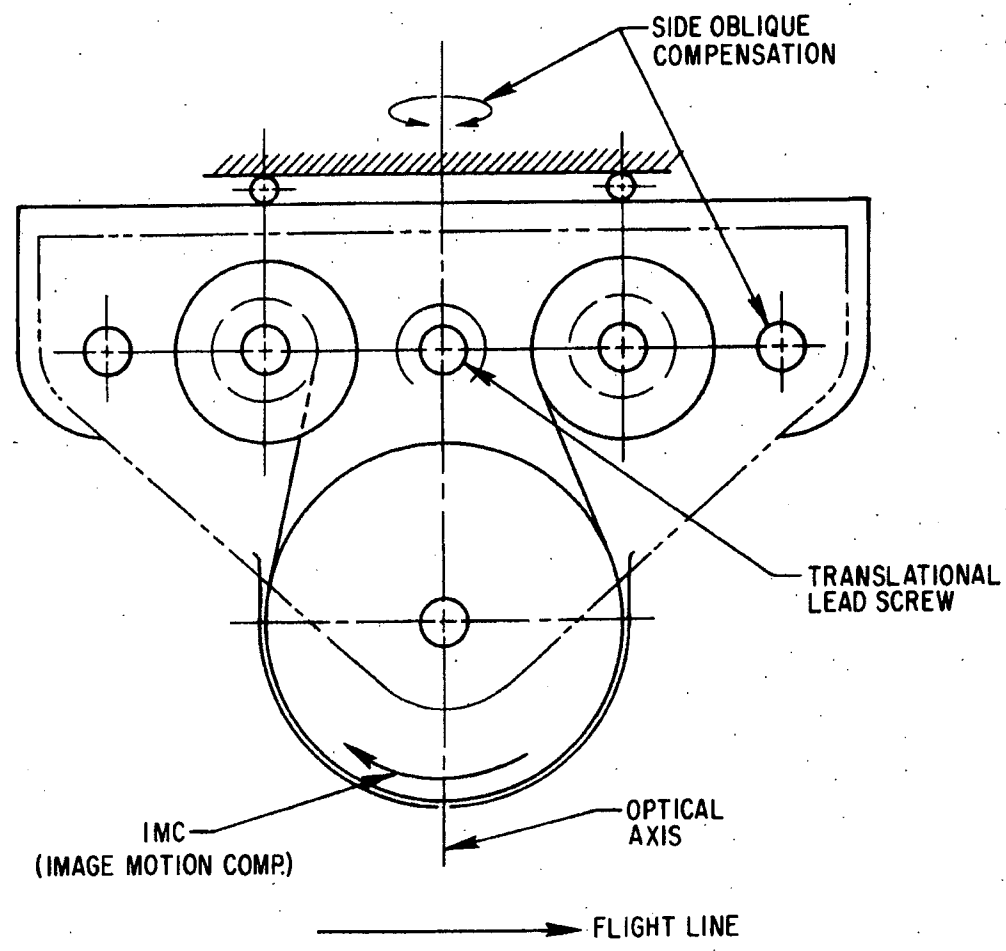
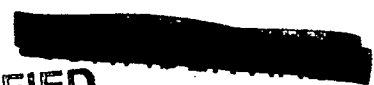
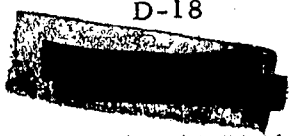

Figure D-13. Film Transport System for Vertical or Side-Oblique Photography Employing a Drum-type Platen

UNCLASSIFIED



D-18



UNCLASSIFIED

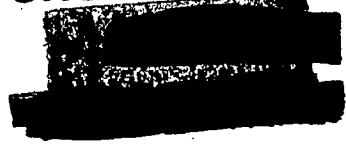

NRO APPROVED FOR
RELEASE 1 JULY 2015

Revised 4 Nov 1965

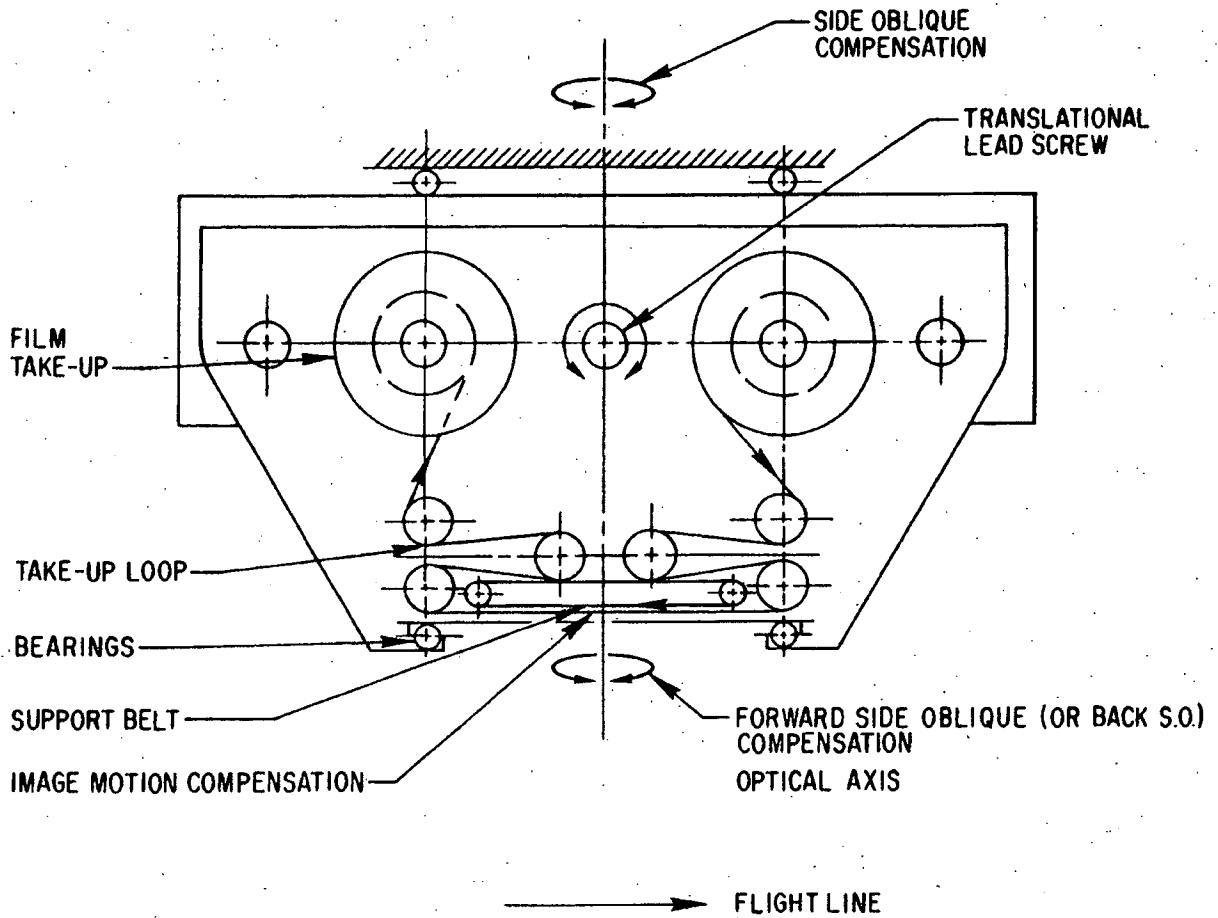
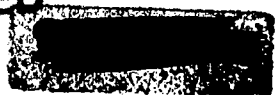

Figure D-14. Schematic of Film Drive Employing Rotating Exposure Slit Plate & Film Support Belt at Focal Plane



UNCLASSIFIED

D-19



UNCLASSIFIED

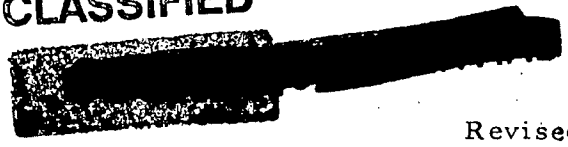

Revised 4 Nov 1965

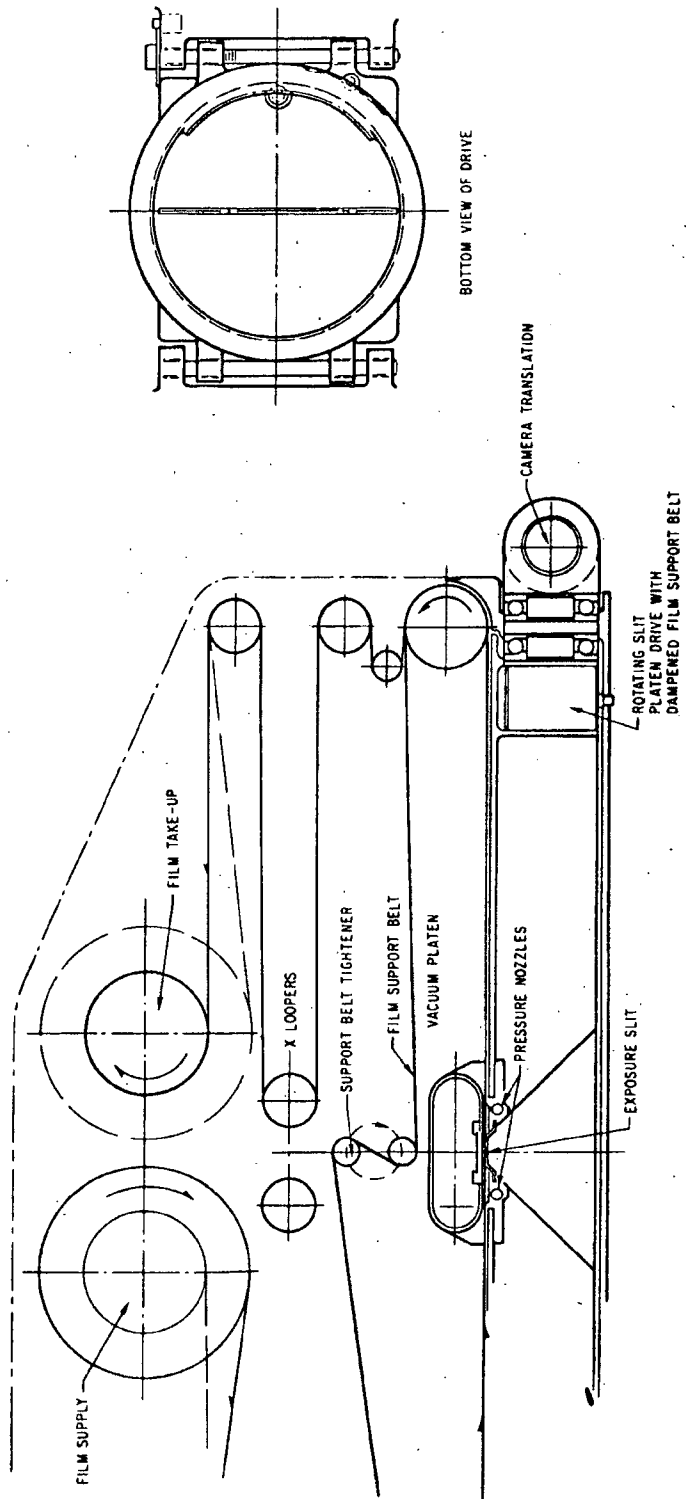
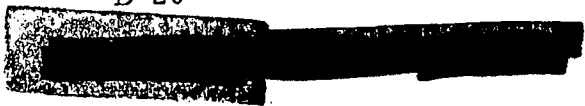

Figure D-15. Preliminary Design for a Film Drive Employing a Closed Loop Vacuum System & Rotating Slit Platen at Focal Plane

UNCLASSIFIED

D-20



[REDACTED]
[REDACTED]
UNCLASSIFIED

Revised 4 Nov 1965

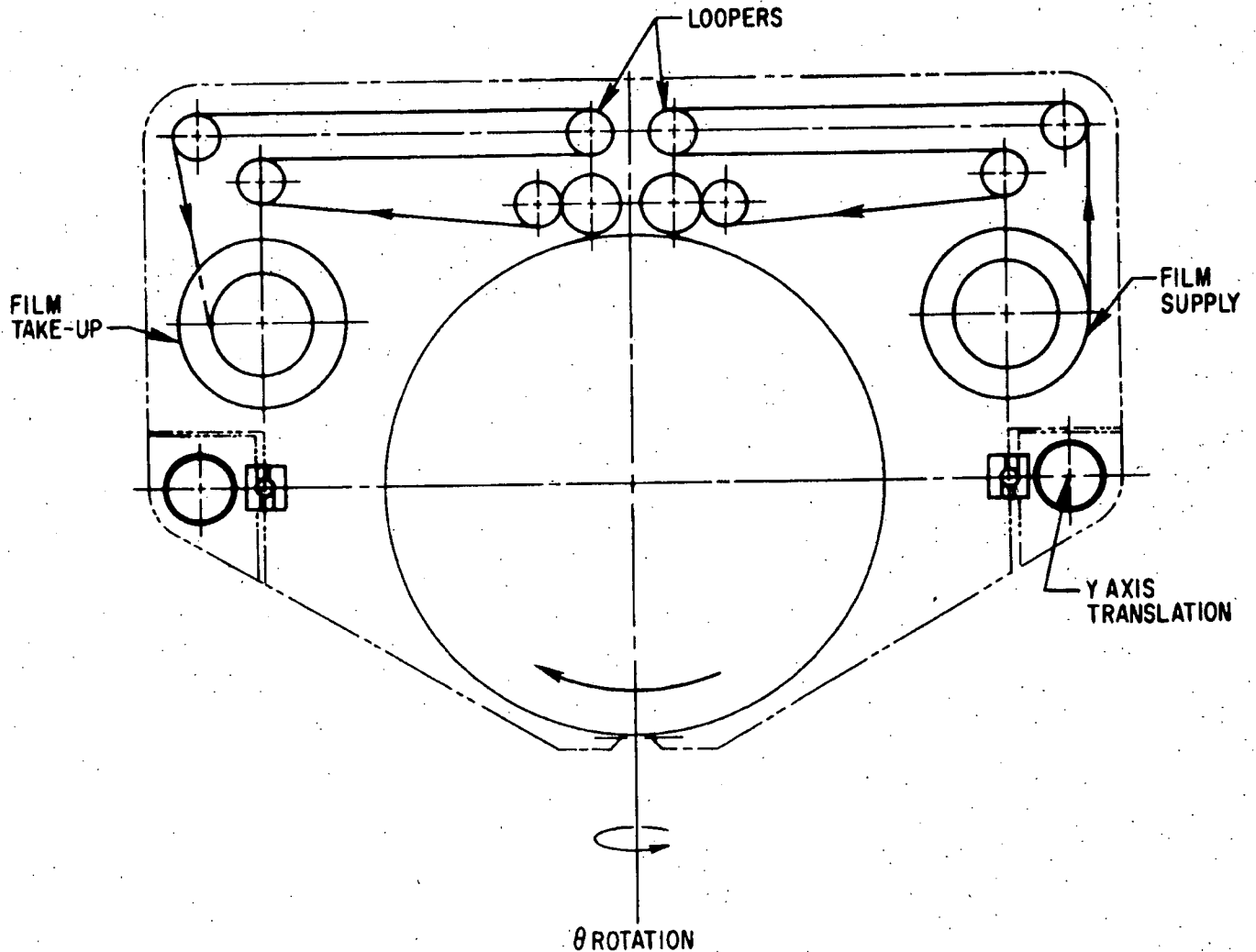
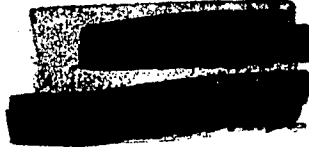

Figure D-16. Schematic of Rotary Drum Film Drive Providing Freedom in Y Axis and Rotation above ϕ (θ)

UNCLASSIFIED

[REDACTED]
D-22
[REDACTED]

UNCLASSIFIED



NRO APPROVED FOR
RELEASE 1 JULY 2015

Revised 4 Nov 1965

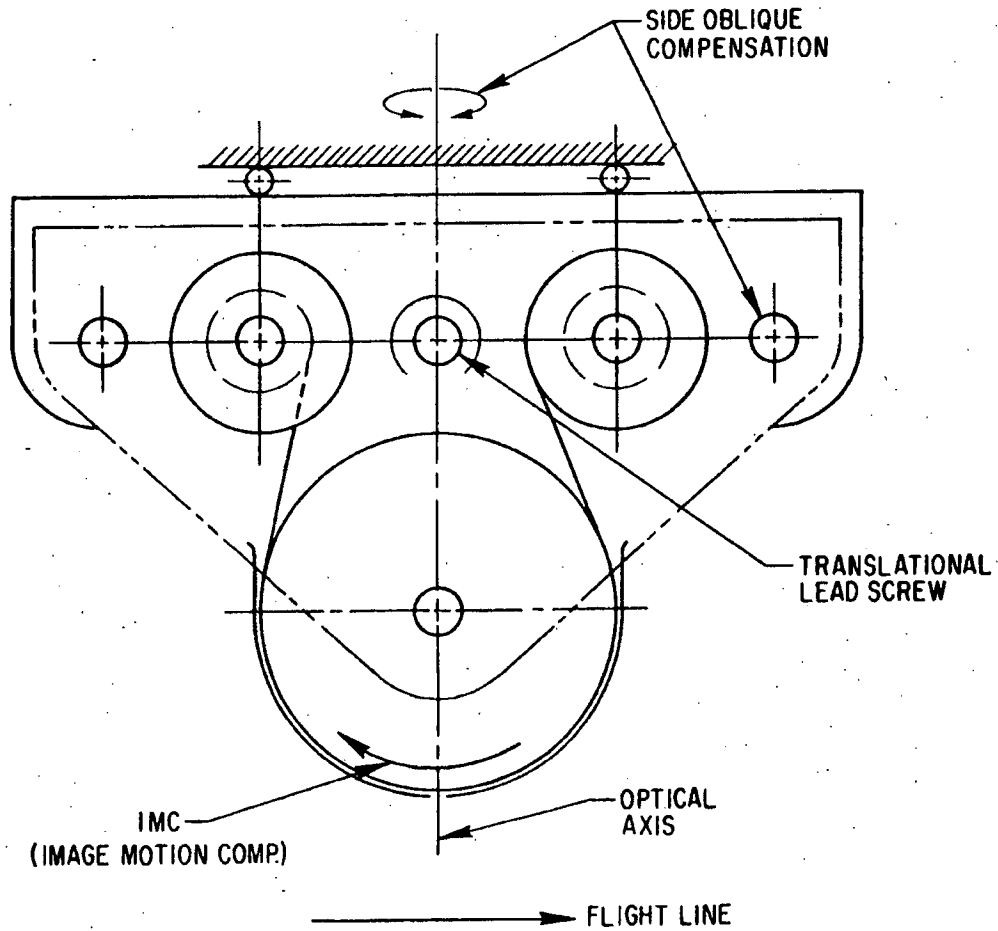

Figure D-19. Film Transport System for Vertical or Side-Oblique Photography Employing a Drum-type Platen

UNCLASSIFIED

D-28



UNCLASSIFIED

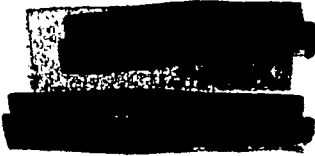

NRO APPROVED FOR
RELEASE 1 JULY 2015

Revised 4 Nov 1965

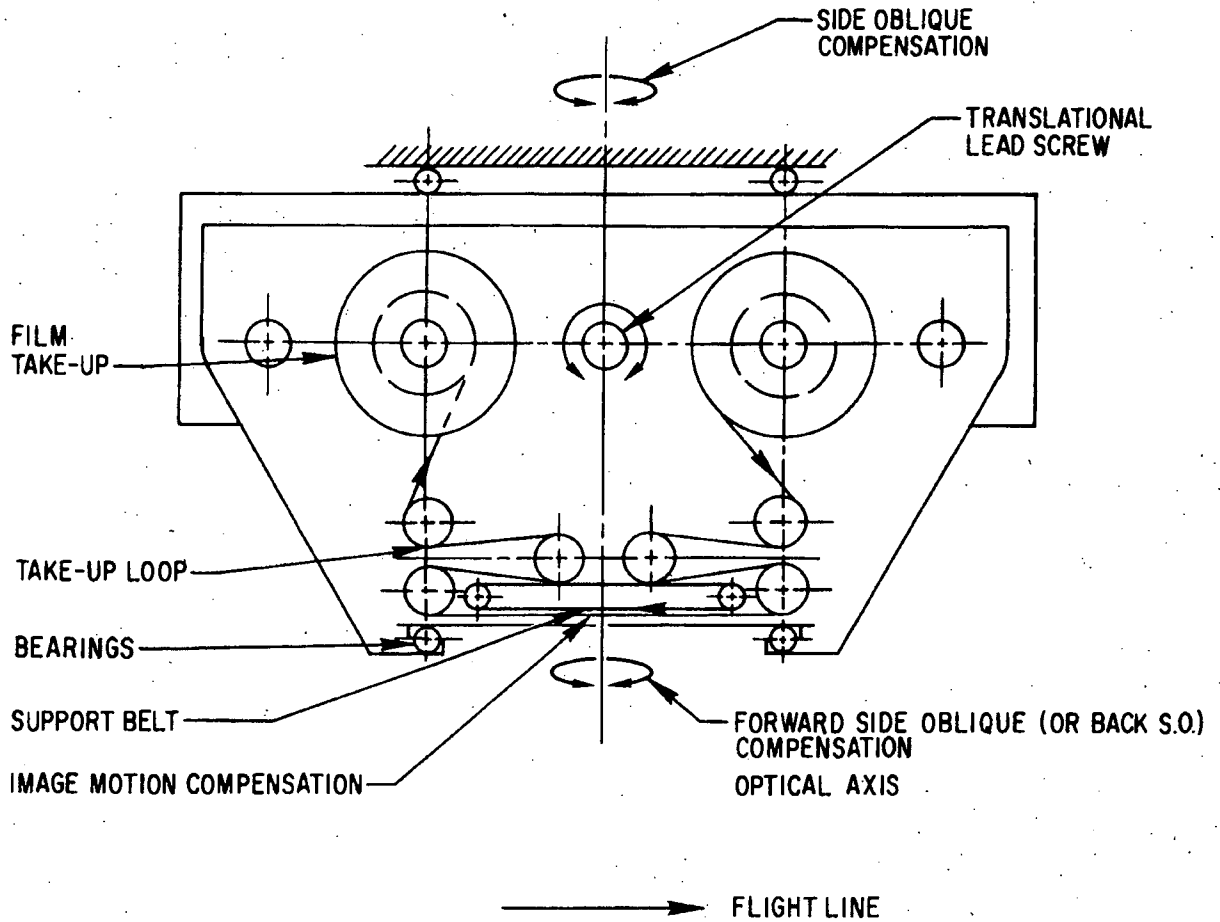
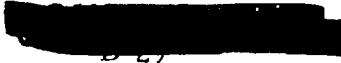

Figure D-20. Schematic of Film Drive Employing Rotating Exposure Slit Plate & Film Support Belt at Focal Plane.

UNCLASSIFIED



[REDACTED]

UNCLASSIFIED

UNCLASSIFIED

[REDACTED]

[REDACTED]

UNCLASSIFIED

DP 12658

Report No.
TOR-269(A4126)-2
Reissue A

ERRATA SHEET

This Errata Sheet applies to Report No. TOR-269(A4126)-2 Reissue A entitled "Gemini Launch Vehicle Working Group, Launch Test Directive, Gemini Launch Vehicle-1 (AF SN 62-12556), " dated 1 April 1964. The information contained herein is in accordance with Systems Test Objective Ammendment 3 dated 16 March 1964. Please make the following changes, in ink, to the subject report.

Page 15, 1st col, item 7:	change "+152.29" to "+153.12".
Page 16, 1st col, item 3:	change "+331.43" to "+333.50".
Page 16, 1st col, item 4:	change "+333.43" to "+335.50".
Page 16, 1st col, item 5:	change "+353.43" to "+355.80".
Page 19, Para B, under Minimum Ullage Volume, item 1:	change "48.5" to "48.0".
Page 19, Para B, under Minimum Ullage Volume, item 2:	change "39.5" to "39.0".
Page 20, Para C2., line 3:	change line 3 to read: "Stage I start cartridge: 60° to 100° F".
Page 20, Para C2., line 4:	change line 4 to read: "Stage II start cartridge: 75° to 100° F". Delete: "(Ref waiver No. D45010 to Stage II AGC spec.)"

UNCLASSIFIED