

~~SECRET~~

(U) PRELIMINARY PERFORMANCE/  
DESIGN REQUIREMENTS

FOR THE

MANNED ORBITING LABORATORY SYSTEM  
(MOL)

GENERAL SPECIFICATION FOR

**ROUGH DRAFT**

( INC )

January 1966

MOL SYSTEMS OFFICE  
LOS ANGELES AIR FORCE STATION

DOWNGRADED AT 12 YEAR  
INTERVALS; NOT AUTOMATICALLY  
DECLASSIFIED. DOD DIR 5200.10

**SPECIAL HANDLING REQUIRED**  
**NOT RELEASABLE TO FOREIGN NATIONALS**

The information contained in this document will not be  
disclosed to foreign nations or their representatives.

**SPECIAL ACCESS REQUIRED**

SENSITIVE AREA  
IDENTITY A&B

PROGRAM No. 632A

This material contains information affecting the  
national defense of the United States within the  
meaning of the Espionage Laws, Title 18, U.S.C.,  
Sections 793 and 794. The transmission or revela-  
tion of which in any manner to an unauthorized  
person is prohibited by law.

~~SECRET~~

~~SECRET~~ SPECIAL HANDLING

ROUGH DRAFT

INCLUDING GENERAL SYSTEM SPECIFICATION  
FOR  
PERFORMANCE AND DESIGN REQUIREMENTS FOR THE DORIAN  
PHOTOGRAPHIC RECONNAISSANCE SATELLITE SYSTEM

January 1966

Approved:

\_\_\_\_\_  
B. F. Knolle, Jr.

Approved:

\_\_\_\_\_  
S. S. Strong

SPECIAL HANDLING

~~SECRET~~

**SPECIAL HANDLING**

~~SECRET~~

FOREWORD

This advance rough draft of the proposed MOL/Dorian Integrated System Specification was prepared based on the so-called manned/unmanned concept. The manned version presented herein assumes automatic operation of the mission payload with manual override capability.

Recent guidelines issued by MOL program management directed discontinuance of the acronym "MUM" and the verbage "manned/unmanned." Instead the following terminology is to be used:

- 1) Manual
- 2) Automatic
- 3) Manned - Automatic

Present plans envisage seven (7) sets of orbiting vehicle hardware to be built and delivered in the manned-automatic configuration. It is also planned to develop and build three (3) kits which will enable conversion from the manned-automatic configuration to a completely automatic configuration.

The issuance of this draft has not been delayed to reflect the above changes. Prior to promulgation of the approved document, references to the "Manned Version" will be changed to read "manned-automatic." Similarly, references to the "Unmanned Version" will be changed to read "automatic."

Another significant difference between this advance rough draft of the Integrated System Specification and SS-MOL-1 dated 3 December 1965, is that this draft makes the Mission Module structure part of the Mission Payload System Segment, whereas SS-MOL-1 states that the Mission Module structure is part of the Laboratory Vehicle System Segment. In a few other areas the white pages also differ somewhat from SS-MOL-1. Until officially superseded, SS-MOL-1 is the approved "white" system specification.

**SPECIAL HANDLING**

~~SECRET~~

~~SPECIAL HANDLING~~

CONTENTS

~~SECRET~~

	<u>Page</u>
1.0 SCOPE	1-1/2
1.1 Descriptive Title	1-1/2
1.2 Purpose	1-1/2
1.3 Mission	1-3
1.3.1 Descriptive Title	1-3
2.0 APPLICABLE DOCUMENTS	2-1
2.1 Specifications	2-2
2.1.1 MIL Specifications	2-2
2.1.2 Air Force BMD/BSD/SSD Exhibits	2-5
2.1.3 Federal Standards	2-6
2.2 Manuals, Regulations, Publications	2-6
2.2.1 Air Force Regulation	2-6
2.2.2 Air Force Manuals	2-7
2.2.3 Air Force Procurement Instructions	2-7
2.2.4 Air Force Pamphlets	2-7
2.2.5 AFSC Regulations	2-8
2.2.6 AFSC Manuals	2-8
2.2.7 Bulletins	2-9
2.3 Other Documents	2-9
2.4 Dorian Exceptions to Applicable Documents Listing	2-11
3.0 REQUIREMENTS	3-1
3.0.1 General	3-1
3.0.2 Performance	3-1
3.0.3 Growth Considerations	3-3
3.0.4 Mission Requirements	3-4
3.0.4.1 Photographic Resolution	3-4
3.0.4.2 Target Access	3-4
3.0.5 Secondary Mission Requirements	3-4
3.1 Performance Characteristics	3-5
3.1.1 Performance Characteristics - General	3-5
3.1.1.1 System Characteristics	3-5
3.1.1.2 Logistics	3-13
3.1.1.3 Personnel and Training	3-14
3.1.1.4 Mission Characteristics	3-16.1

~~SPECIAL HANDLING~~

~~SECRET~~

~~SECRET~~

SPECIAL HANDLING

CONTENTS (Continued)

	<u>Page</u>
3.1.2 System Definition	3-17
3.1.2.1 System Engineering Documentation	3-17
3.1.2.2 System Segment List	3-28
3.1.2.3 Contract End Item List	3-28
3.1.2.4 Dorian Functional Flow Diagram	3-28.1
3.1.3 System Effectiveness	3-29
3.1.3.1 Effectiveness Measures	3-29
3.1.3.2 Maintainability	3-31
3.1.3.3 Useful Life	3-32
3.1.3.4 Environment-Natural and Induced	3-32
3.1.3.5 Transportability and Handling	3-33
3.1.3.6 Human Performance	3-33
3.1.3.7 Safety	3-34
3.1.3.8 Dangerous Materials and Components	3-35/36
3.1.3.9 Noise and Vibration	3-35/36
3.1.3.10 Life Support	3-35/36
3.2 System Design and Construction Standards	3-37
3.2.1 General Design and Construction Requirements	3-37
3.2.1.1 Selection of Specifications and Standards	3-37
3.2.1.2 Materials, Parts, and Processes	3-38
3.2.1.3 Standard and Commercial Parts	3-38
3.2.1.4 Moisture and Fungus Resistance	3-39
3.2.1.5 Corrosion of Metal Parts	3-39
3.2.1.6 Interchangeability and Replaceability	3-40
3.2.1.7 Workmanship	3-40
3.2.1.8 Electromagnetic Interference	3-41
3.2.1.9 Identification and Marking	3-42
3.2.1.10 Storage	3-42
3.2.2 Design Disciplines	3-42
3.2.2.1 Electrical	3-43/44
3.2.2.2 Mechanical	3-43/44
3.2.2.3 Hydraulic and Pneumatic	3-43/44

~~SECRET~~ SPECIAL HANDLING

~~SECRET~~

SPECIAL HANDLING

CONTENTS (Continued)

	<u>Page</u>
3.2.2.4 Civil	3-43/44
3.2.2.5 Human Engineering	3-43/44
3.2.2.6 Safety	3-43/44
3.2.2.7 Maintenance Support and Spares Provisioning	3-43/44
3.2.2.8 Environmental Criteria	3-43/44
3.2.3 Dorian Exceptions	3-44.1
3.3 Performance Allocations	3-45
3.3.1 Orbiting Vehicle System Segment	3-45
3.3.1.1 Allocated Performance and Design Requirements	3-45
3.3.1.2 Peculiar Performance and Design Requirements	3-47
3.3.1.3 Functional Interfaces	3-52
3.3.1.4 Contract End Items	3-52
3.3.1.5 Mission Peculiar Requirements, Orbiting Vehicle	3-52.1
3.3.2 Laboratory Vehicle System Segment	3-53
3.3.2.1 Allocated Performance and Design Requirements	3-53
3.3.2.2 Peculiar Performance and Design Requirements	3-55
3.3.2.3 Functional Interfaces	3-85/86
3.3.2.4 Contract End Items	3-85/86
3.3.2.5 Mission Peculiar Requirements, Laboratory Vehicle	3-86.1
3.3.3 Gemini B System Segment	3-87
3.3.3.1 Allocated Performance and Design Requirements	3-87
3.3.3.2 Peculiar Performance and Design Requirements	3-88
3.3.3.3 Functional Interfaces	3-102
3.3.3.4 Contract End Items	3-102
3.3.4 Mission Payload System Segment	3-103/104
3.3.4.1 Allocated Performance and Design Requirements	3-103/104
3.3.4.2 Mission Payload Performance and Design Requirements	3-104.1
3.3.4.3 Mission Module Section	3-104.7
3.3.4.4 Data Re-entry Vehicle Section	3-104.16
3.3.4.5 Photographic Section	3-104.24
3.3.4.6 Aerospace Ground Equipment Requirements	3-104.35
3.3.4.7 Mission Payload Functional Interfaces	3-104.36
3.3.4.8 Contract End Item List (CEI)	3-104.36

~~SECRET~~

SPECIAL HANDLING

~~SECRET~~

SPECIAL HANDLING

CONTENTS (Continued)

	<u>Page</u>
3.3.5 Crew Equipment System Segment	3-105
3.3.5.1 Allocated Performance and Design Requirements	3-105
3.3.5.2 Peculiar Performance and Design Requirements	3-108
3.3.5.3 Functional Interfaces	3-111/112
3.3.5.4 Contract End Items	3-111/112
3.3.6 Titan III System Segment	3-113
3.3.6.1 Allocated Performance and Design Requirements	3-113
3.3.6.2 Peculiar Performance and Design Requirements	3-115
3.3.6.3 Functional Interfaces	3-117/118
3.3.6.4 Contract End Items	3-117/118
3.3.7 Facilities System Segment	3-119
3.3.7.1 Allocated Performance and Design Requirements	3-119
3.3.7.2 Peculiar Performance and Design Requirements	3-119
3.3.7.3 Functional Interfaces	3-122
3.3.7.4 Contract End Items	3-122.1
3.3.7.5 Mission Payload Facility Requirements	3-122.1
3.3.8 Launch Operations System Segment	3-123
3.3.8.1 Pre-launch Operations	3-123
3.3.8.2 Launch Operations	3-123
3.3.8.3 Functional Interfaces	3-124
3.3.8.4 Contract End Items	3-124
3.3.8.5 Mission Payload Launch Operations Support	3-124.1
3.3.9 Flight Operations and Support System Segment	3-125
3.3.9.1 Mission Control Operations	3-125
3.3.9.2 Flight Operations Support	3-132
3.3.9.3 Functional Interfaces	3-138
3.3.9.4 Contract End Items	3-138
3.3.9.5 Payload Operations Control Requirements	3-140.1
3.3.10 Recovery System Segment	3-141
3.3.10.1 Recovery Operations	3-141
3.3.10.2 Recovery Force	3-141
3.3.10.3 Access and Retrieval	3-142
3.3.10.4 Post Recovery	3-142

~~SECRET~~

SPECIAL HANDLING

~~SECRET~~ SPECIAL HANDLING

CONTENTS (Continued)

	<u>Page</u>
3.3.10.5 Payload Recovery Requirements	3-142.1
3.3.11 Test Support System Segment	3-143
3.3.11.1 Pre-launch Support	3-143
3.3.11.2 Launch and Ascent Support	3-143
3.3.11.3 On-Orbit and Recovery Support	3-144
3.3.12 Flight Crew System Segment	3-147
3.3.12.1 Allocated Performance and Design Requirements	3-147
3.3.12.2 Peculiar Performance and Design Requirements	3-147
3.3.12.3 Functional Interfaces	3-149/150
3.3.12.4 Contract End Items	3-149/150
3.3.12.5 Flight Crew Dorian Support Requirements	3-150.1
4.0 PERFORMANCE/DESIGN VERIFICATION AND TEST	4-1
4.1 Ground Test Requirements	4-1
4.1.1 Development Tests	4-1
4.1.1.1 General Requirements	4-1
4.1.1.2 Over-all System Requirements	4-1
4.1.1.3 Orbiting Vehicle Requirements	4-1
4.1.1.4 Laboratory Vehicle Requirements	4-2
4.1.1.5 Gemini B Requirements	4-4
4.1.1.6 Mission Payload Segment Requirements	4-5
4.1.1.7 Titan III Requirements	4-5
4.1.1.8 Crew Equipment Requirements	4-5
4.1.1.9 Operations Compatibility Requirements	4-5
4.1.1.10 Aerospace Ground Equipment Requirements	4-5
4.1.1.11 Orbiting Vehicle Mission Simulator Requirements	4-5
4.1.2 Qualification Tests	4-6
4.1.2.1 General Requirements	4-6
4.1.2.2 Over-all System Requirements	4-6
4.1.2.3 Orbiting Vehicle Requirements	4-6
4.1.2.4 Laboratory Vehicle Requirements	4-7
4.1.2.5 Gemini B Requirements	4-7
4.1.2.6 Mission Payload Requirements	4-8
4.1.2.7 Titan III Requirements	4-8

~~SECRET~~ SPECIAL HANDLING

17



~~SECRET~~ SPECIAL HANDLING

CONTENTS (Continued)

	<u>Page</u>
4.1.2.8 Flight Crew Equipment Requirements	4-8
4.1.2.9 Launch Operations, Flight Operations, Recovery and Test Support Equipment Requirements	4-8
4.1.2.10 Aerospace Ground Equipment Requirements	4-8
4.1.2.11 Mission Simulator Requirements	4-9
4.1.3 Effectiveness Testing	4-9
4.1.4 Acceptance and Flight Readiness Tests	4-9
4.1.4.1 Acceptance Test Requirements	4-9
4.1.4.2 Flight Readiness Test Requirements	4-10
4.1.4.3 Orbiting Vehicle Requirements	4-10
4.1.4.4 Laboratory Vehicle Requirements	4-10
4.1.4.5 Gemini B Requirements	4-10
4.1.4.6 Mission Payload Segment Requirements	4-10
4.1.4.7 Titan III Requirements	4-11
4.1.4.8 Flight Crew Equipment Requirements	4-11
4.1.4.9 Launch Operations, Flight Operations, Recovery and Test Support System Segment Requirements	4-11
4.1.4.10 Aerospace Ground Equipment (AGE) Requirements	4-11
4.1.4.11 Mission Simulator Requirements	4-12 X
4.2 MOL System Flight Test Requirements	4-12
4.2.1 Test Program Description	4-12
4.2.2 Titan III Development Flight Test (MOL Flight #1)	4-12
4.2.3 MOL Development Flight Test (MOL Flight #2)	4-13
4.2.4 MOL Flight Tests (MOL Flight #3 and Subsequent)	4-13
4.3 Dorian System Flight Certification Testing	4-15
4.3.1 Qualification Testing	4-15
4.3.2 Acceptance Testing	4-15
5.0 PREPARATION FOR DELIVERY	5-1/2
5.1 Packaging	5-1/2
GLOSSARY	
VEHICLE COORDINATE SYSTEM DEFINITION	A-1
Attachment 1 - Method for Statistical Analysis of Attitude Control System Accuracy	
Attachment 2 - Mission Payload Performance Prediction	

~~SECRET~~ SPECIAL HANDLING

X  
/

~~SECRET~~

SPECIAL HANDLING  
**SPECIAL HANDLING**

FIGURES

3-1	MOL Orbiting Vehicle Segment Orbit Altitude Constraint	3-15/16
3-1.1	Orbit Envelope	3-16.3
3-1.2	Nadir Resolution vs Sun Angle	3-16.4
3-1.3	Across the Format IMC	3-16.5
3-2	MOL System Top Level Functional Flow Diagram	3-20
3-3	MOL System Flow Diagram Code	3-21
3-4	MOL System Flow Schematic	3-22
3-5	Manned Dorian System Integration Functional Flow	3-28.2 X
3-6	Unmanned Dorian System Integration Functional Flow	3-28.3 X
3-7	Dorian System (Manned - Automatic Configuration)	3-104.2 X
3-8	Dorian System (Automatic Configuration)	3-104.3 X
3-9	Optical Sensor Basic Configuration	3-104.25
3-10	Resolution Versus Contrast	3-104.29
3-11	Dorian System Specification Tree (Manned - Automatic)	3-104.37
3-12	Dorian System Specification Tree (Automatic)	3-104.38

~~SECRET~~

**SPECIAL HANDLING**

SPECIAL HANDLING

APPENDIX A

VEHICLE COORDINATE SYSTEM  
DEFINITION

*LAUNCH 120000*  
MOL LAUNCH CONFIGURATION

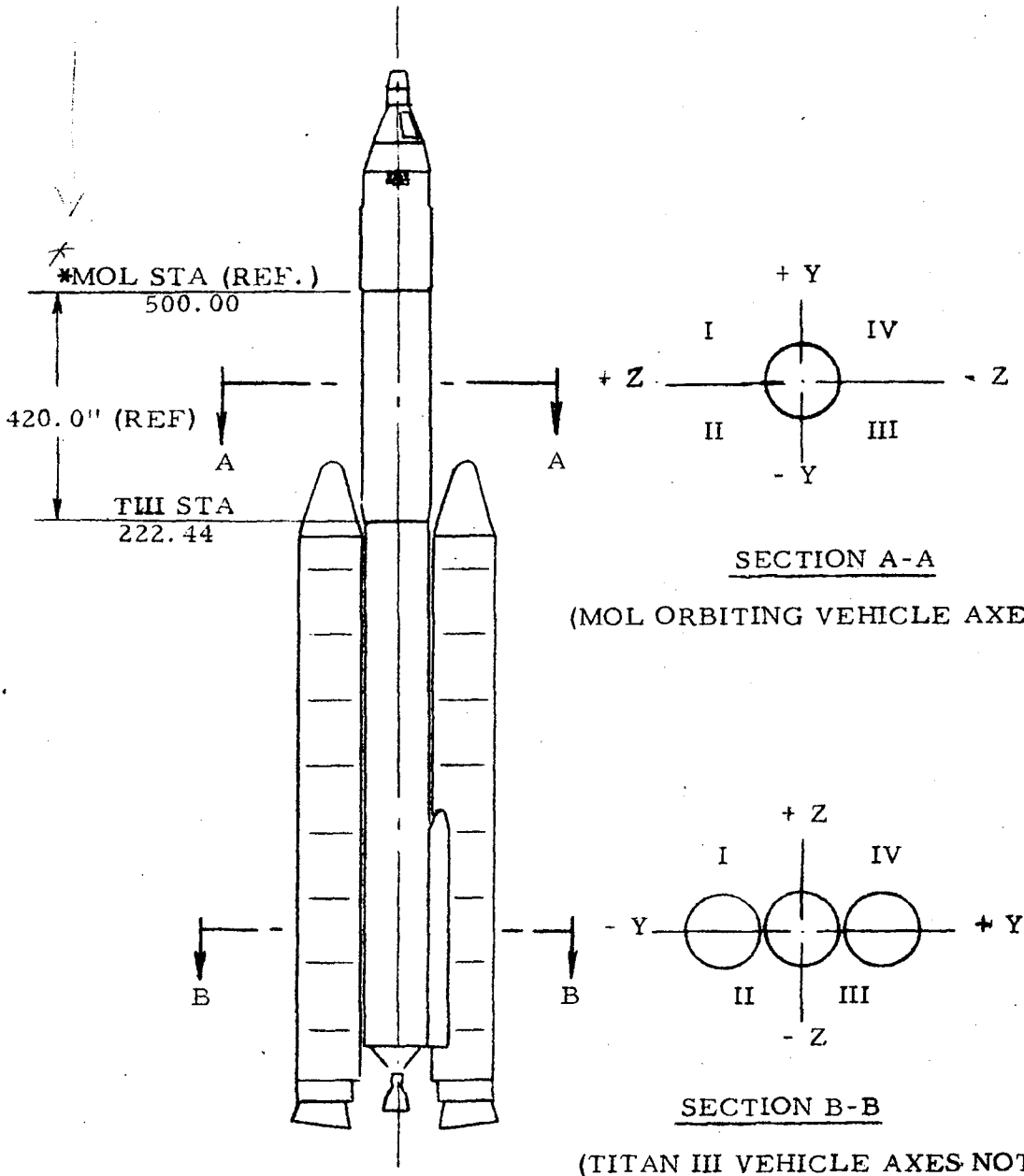

*MOL station numbers increase going forward*

\*MOL station numbers increase going forward.

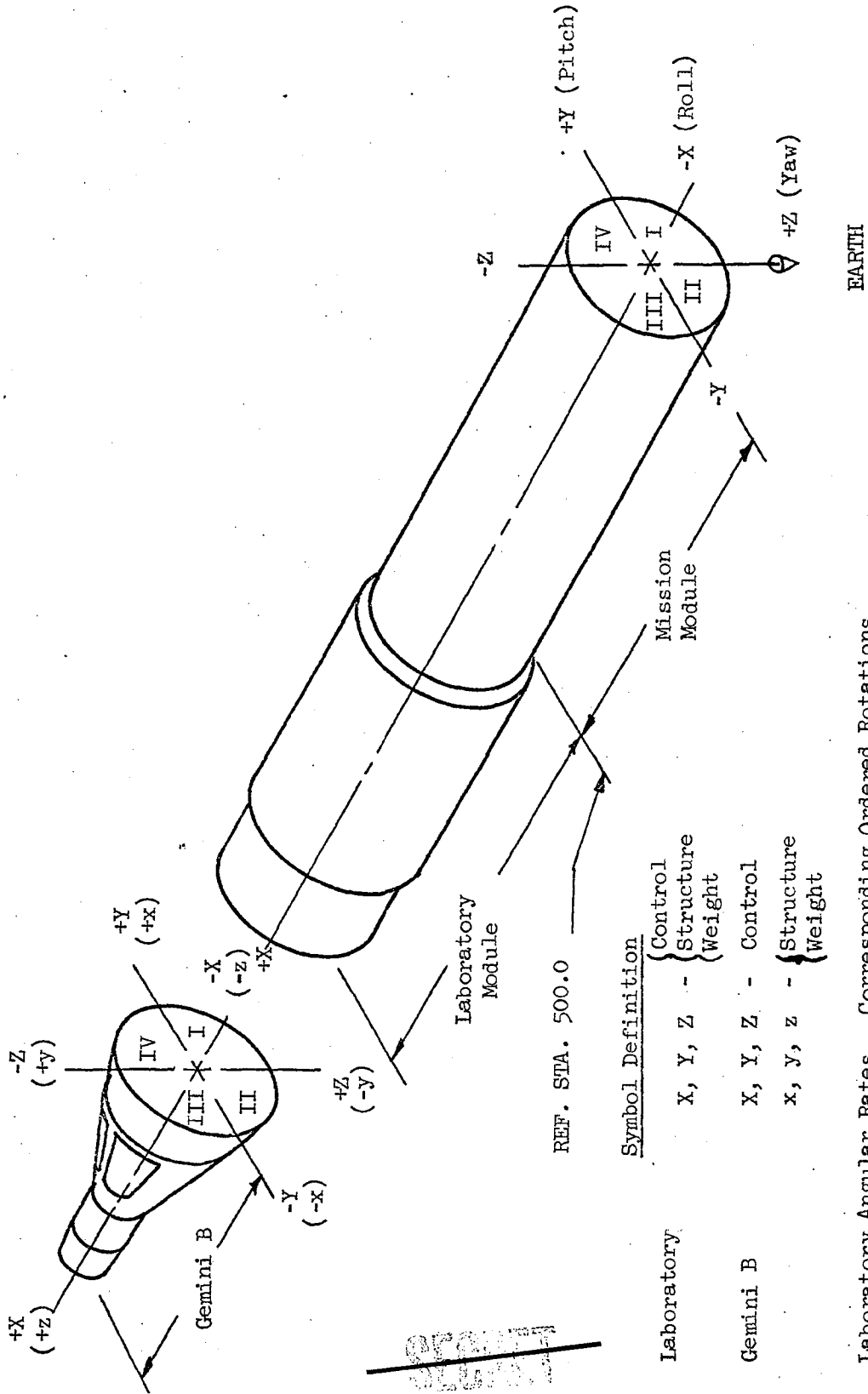

Symbol Definition	
Laboratory	$X, Y, Z$ - { Control Structure Weight
Gemini B	$X, Y, Z$ - Control
	$x, y, z$ - { Structure Weight

Laboratory Angular Rates Corresponding Ordered Rotations

1. Yaw about  $+Z$  ----- "Yaw" is  $\psi$
2. Pitch about  $+Y$  ----- "Pitch" is  $\phi$  (Use right hand rule for positive rotations)
3. Roll about  $+X$  ----- "Roll" is  $\phi$

MANNED VERSION COORDINATE SYSTEM DEFINITION

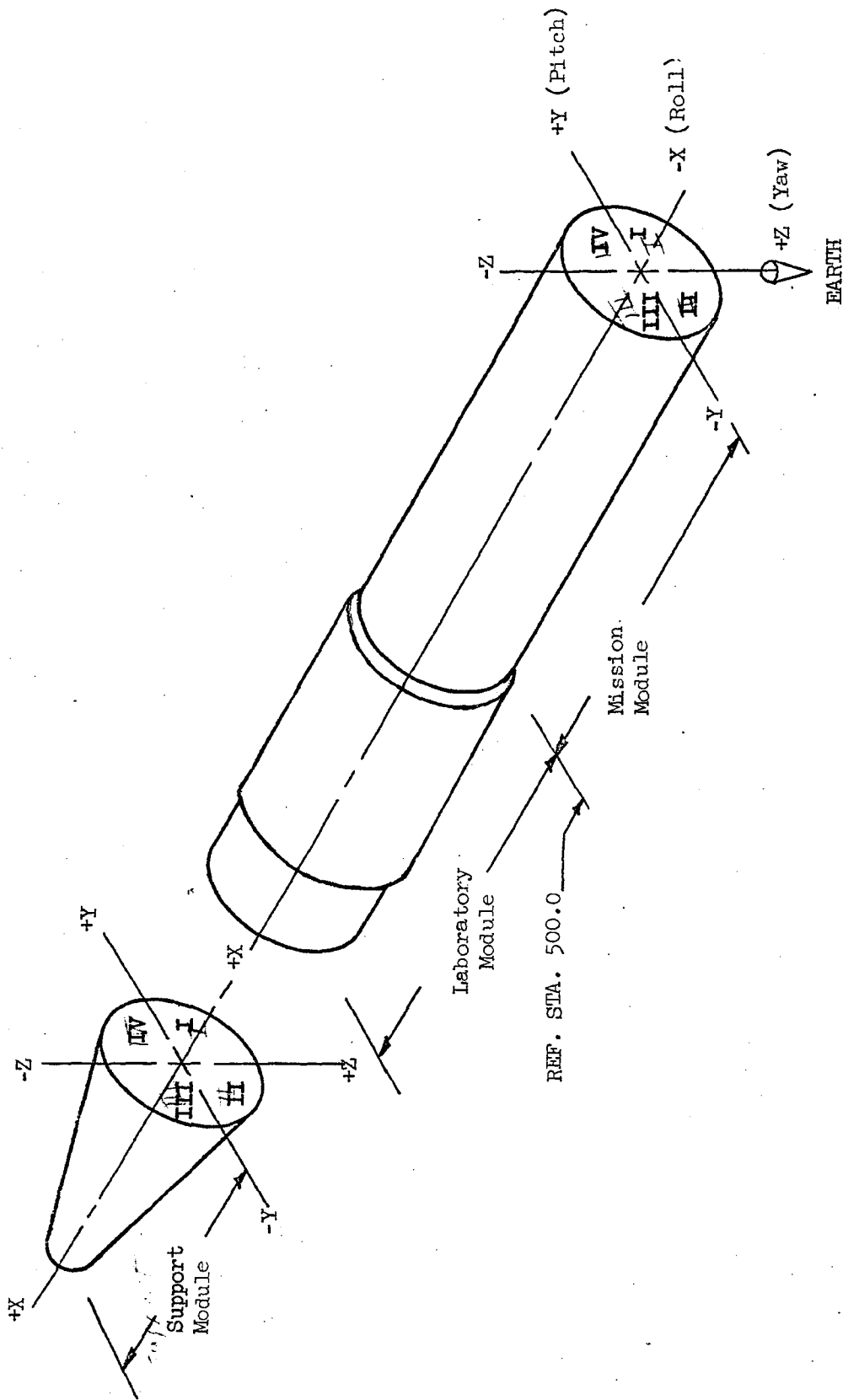

UNMANNED VERSION COORDINATE SYSTEM DEFINITION

ATTACHMENT 1

METHOD FOR STATISTICAL ANALYSIS OF ATTITUDE CONTROL SYSTEM ACCURACY

(Later)

~~SECRET~~  
SPECIAL HANDLING

ATTACHMENT 2

MISSION PAYLOAD PERFORMANCE PREDICTION

Modulation Transfer Function (MTF) techniques are used to predict photographic system performance. The parameters which affect resolution are: operating altitude; target position and contrast; lens parameters (focal length, aperture, semi-field angle, percent obstruction, and transmission); optical quality factor; focus; residual image motion; shutter efficiency; wavelength of light; and average minimum scene luminance.

The MTF of the lens is computed for the selected lens parameters and then multiplied by the optical quality factor. A transfer function is computed for the combination of shutter efficiency and residual image motion. Target modulation resulting from the contrast of a standard tri-bar test object (in accordance with Figure 1 of MIL-STD-150A) is multiplied by the above MTF's to obtain an image modulation curve. This curve represents the total modulation of the image at the film plane versus spatial frequency, and its intersection with the aerial image modulation curve gives the threshold lens-film resolution of the system. The threshold resolution is given in lines/mm at the film plane and must be combined with focal length to obtain angular resolution. The relationships between film resolution, angular resolution, and ground resolution are as follows:

$$\begin{aligned} \text{Film resolution:} & \quad 1/R_f = F \theta \\ \text{Ground resolution:} & \quad R_g = h \theta (\cos \Sigma \cos \Omega)^{-3/2} \end{aligned}$$

where  $R_f$  = film resolution in cycles/linear distance

- $R_g$  = Ground resolution in linear distance
- $\theta$  = Angular resolution in radians
- $F$  = Focal length
- $h$  = Altitude
- $\Sigma$  = Stereo angle
- $\Omega$  = Obliquity angle

~~SECRET~~ SPECIAL HANDLING



~~SECRET~~  
SPECIAL HANDLING

Mission average angular resolution is used to estimate average system performance over the ranges of expected operating conditions. The within-mission random variables included are obliquity aim angle, focus variations, deviation from nominal exposure conditions, and residual image motion.

Monte Carlo techniques are used to determine mission average angular resolution. A computer program has been written for this purpose. The computer selects a value from each of the four random distributions (random smear rate, exposure, focus, and obliquity) and calculates the corresponding angular resolution and ground resolution. This selection of a set of random variables and the calculation of resolution is repeated "N" times for each set of fixed input variables. Mission average angular resolution is then the average of the individual angular resolutions, and the individual ground resolutions can be used to plot cumulative resolution probability.

This approach to determining average resolution is based on the central limit theorem which says that if a sufficient number of samples are chosen at random from an infinite population, the average of the samples approaches the average of the population. A statistical evaluation of trial cases indicated that a sample size of  $N = 100$  is required to determine mission average performance for the specified manned photographic system.

~~SECRET~~  
SPECIAL HANDLING

## CONTENTS

1.0	SCOPE.....	1-1/2
1.1	Descriptive Title.....	1-1/2
1.2	Purpose.....	1-1/2
2.0	APPLICABLE DOCUMENTS.....	2-1
2.1	Specifications, Standards, and Exhibits.....	2-2
2.2	Manuals, Regulations, Publications.....	2-6
2.3	Other Documents.....	2-9
3.0	REQUIREMENTS.....	3-1
3.0.1	General.....	3-1
3.0.2	Performance.....	3-1
3.0.3	Growth Considerations.....	3-3/4
3.1	Performance Characteristics.....	3-5
3.1.1	Performance Characteristics - General.....	3-5
3.1.1.1	System Characteristics.....	3-5
3.1.1.2	Logistics.....	3-13
3.1.1.3	Personnel and Training.....	3-14
3.1.2	System Definition.....	3-17
3.1.2.1	System Engineering Documentation.....	3-17
3.1.2.2	System Segment List.....	3-28
3.1.2.3	Contract End Item List.....	3-28
3.1.2.4	Deleted.....	3-28
3.1.3	System Effectiveness.....	3-29
3.1.3.1	Effectiveness Measures.....	3-29
3.1.3.2	Maintainability.....	3-31
3.1.3.3	Useful Life.....	3-32
3.1.3.4	Environment - Natural and Induced.....	3-32
3.1.3.5	Transportability and Handling.....	3-33

CONTENTS (Continued)

3.1.3.6	Human Performance . . . . .	3-33
3.1.3.7	Safety . . . . .	3-34
3.1.3.8	Dangerous Materials and Components . . . . .	3-35/36
3.1.3.9	Noise and Vibration . . . . .	3-35/36
3.1.3.10	Life Support . . . . .	3-35/36
3.2	System Design and Construction Standards . . . . .	3-37
3.2.1	General Design and Construction Requirements . . . . .	3-37
3.2.1.1	Selection of Specifications and Standards . . . . .	3-37
3.2.1.2	Materials, Parts, and Processes . . . . .	3-38
3.2.1.3	Standard and Commercial Parts . . . . .	3-38
3.2.1.4	Moisture and Fungus Resistance . . . . .	3-39
3.2.1.5	Corrosion of Metal Parts . . . . .	3-39
3.2.1.6	Interchangeability and Replaceability . . . . .	3-40
3.2.1.7	Workmanship . . . . .	3-40
3.2.1.8	Electromagnetic Interference . . . . .	3-41
3.2.1.9	Identification and Marking . . . . .	3-42
3.2.1.10	Storage . . . . .	3-42
3.2.2	Design Disciplines . . . . .	3-42
3.2.2.1	Electrical . . . . .	3-43/44
3.2.2.2	Mechanical . . . . .	3-43/44
3.2.2.3	Hydraulic and Pneumatic . . . . .	3-43/44
3.2.2.4	Civil . . . . .	3-43/44
3.2.2.5	Human Engineering . . . . .	3-43/44
3.2.2.6	Safety . . . . .	3-43/44

CONTENTS (Continued)

3.2.2.7	Maintenance Support . . . . .	3-43/44
3.2.2.8	Environmental Criteria . . . . .	3-43/44
3.3	Performance Allocations . . . . .	3-45
3.3.1	Orbiting Vehicle System Segment . . . . .	3-45
3.3.1.1	Allocated Performance and Design Requirements . . . . .	3-45
3.3.1.2	Peculiar Performance and Design Requirements . . . . .	3-46
3.3.1.3	Functional Interfaces . . . . .	3-52
3.3.1.4	Contract End Items . . . . .	3-52
3.3.2	Laboratory Vehicle System Segment . . . . .	3-53
3.3.2.1	Allocated Performance and Design Requirements . . . . .	3-53
3.3.2.2	Peculiar Performance and Design Requirements . . . . .	3-55
3.3.2.3	Functional Interfaces . . . . .	3-85/86
3.3.2.4	Contract End Items . . . . .	3-85/86
3.3.3	Gemini B System Segment . . . . .	3-87
3.3.3.1	Allocated Performance and Design Requirements . . . . .	3-87
3.3.3.2	Peculiar Performance and Design Requirements . . . . .	3-88
3.3.3.3	Functional Interfaces . . . . .	3-102
3.3.3.4	Contract End Items . . . . .	3-102
3.3.4	Mission Payload System Segment . . . . .	3-103/104
3.3.4.1	Allocated Performance and Design Requirements . . . . .	3-103/104
3.3.4.2	Peculiar Performance and Design Requirements . . . . .	3-103/104
3.3.4.3	Functional Interfaces . . . . .	3-103/104
3.3.4.4	Contract End Items . . . . .	3-103/104
3.3.5	Crew Equipment System Segment . . . . .	3-105
3.3.5.1	Allocated Performance and Design Requirements . . . . .	3-105

CONTENTS (Continued)

3.3.5.2	Peculiar Performance and Design Requirements . . . . .	3-108
3.3.5.3	Functional Interfaces . . . . .	3-111/112
3.3.5.4	Contract End Items . . . . .	3-111/112
3.3.6	Titan III System Segment . . . . .	3-113
3.3.6.1	Allocated Performance and Design Requirements . . . . .	3-113
3.3.6.2	Peculiar Performance and Design Requirements . . . . .	3-115
3.3.6.3	Functional Interfaces . . . . .	3-117/118
3.3.6.4	Contract End Items . . . . .	3-117/118
3.3.7	Facilities System Segment . . . . .	3-119
3.3.7.1	Allocated Performance and Design Requirements . . . . .	3-119
3.3.7.2	Peculiar Performance and Design Requirements . . . . .	3-119
3.3.7.3	Functional Interfaces . . . . .	3-122
3.3.7.4	Contract End Items . . . . .	3-122
3.3.8	Launch Operations System Segment . . . . .	3-123
3.3.8.1	Pre-launch Operations . . . . .	3-123
3.3.8.2	Launch Operations . . . . .	3-123
3.3.8.3	Functional Interfaces . . . . .	3-124
3.3.8.4	Contract End Items . . . . .	3-124
3.3.9	Flight Operations and Support System Segment . . . . .	3-125
3.3.9.1	Mission Control Operations . . . . .	3-125
3.3.9.2	Flight Operations Support . . . . .	3-132
3.3.9.3	Functional Interfaces . . . . .	3-139/140
3.3.9.4	Contract End Items . . . . .	3-139/140
3.3.10	Recovery System Segment . . . . .	3-141
3.3.10.1	Recovery Operation . . . . .	3-141
3.3.10.2	Recovery Force . . . . .	3-141
3.3.10.3	Access and Retrieval . . . . .	3-142

CONTENTS (Continued)

3. 3. 10. 4	Post Recovery . . . . .	3-142
3. 3. 11	Test Support System Segment . . . . .	3-143
3. 3. 11. 1	Pre-launch Support . . . . .	3-143
3. 3. 11. 2	Launch and Ascent Support. . . . .	3-143
3. 3. 11. 3	On-Orbit and Recovery Support . . . . .	3-144
3. 3. 12	Flight Crew System Segment . . . . .	3-147
3. 3. 12. 1	Allocated Performance and Design Requirements . . . . .	3-147
3. 3. 12. 2	Peculiar Performance and Design Requirements . . . . .	3-147
3. 3. 12. 3	Functional Interfaces . . . . .	3-149/150
3. 3. 12. 4	Contract End Items . . . . .	3-149/150
4. 0	PERFORMANCE/DESIGN VERIFICATION AND TEST.	4-1
4. 1	Ground Test Requirements . . . . .	4-1
4. 1. 1	Development Tests . . . . .	4-1
4. 1. 2	Qualification Tests . . . . .	4-6
4. 1. 3	Effectiveness Testing . . . . .	4-9
4. 1. 4	Acceptance and Flight Readiness Tests . . . . .	4-9
4. 2	MOL System Flight Test Requirements . . . . .	4-12
4. 2. 1	Test Program Description. . . . .	4-12
4. 2. 2	Titan-III Development Flight Test (MOL Flight No. 1) . . . . .	4-12
4. 2. 3	MOL Development Flight Test (MOL Flight No. 2) . . . . .	4-13
4. 2. 4	MOL Flight Tests (MOL Flight No. 3 and Subsequent) . . . . .	4-13
5. 0	PREPARATION FOR DELIVERY . . . . .	5-1/2
5. 1	Packaging . . . . .	5-1/2

GLOSSARY

FIGURES

3-1	MOL Orbiting Vehicle Segment Orbit Altitude Constraint . . . . .	3-15/16
3-2	MOL System Top Level Functional Flow Diagram . . .	3-20
3-3	MOL System Flow Diagram Code . . . . .	3-21
3-4	MOL System Flow Schematic . . . . .	3-22

~~CONFIDENTIAL~~

1.0 SCOPE

This specification establishes the performance, design, development, and test requirements for the Manned Orbiting Laboratory (MOL) System. All elements and contract end items (CEI) of the MOL System shall conform to the requirements delineated herein. (U)

1.1 DESCRIPTIVE TITLE

The descriptive title for the total system shall be the "Manned Orbiting Laboratory System" (or "MOL System"). (U)

1.2 PURPOSE

A primary objective of the MOL Program is development of technology to improve capabilities for manned and unmanned operations of military significance.\* This may include intermediate steps toward operational systems.

This objective shall be accomplished as early as possible, with minimum system cost and with careful attention to safety aspects. Minimizing cost and time for development and test, as well as enhancing system effectiveness implies a minimum of innovations. Proven vehicle and ground hardware, procedures, and facilities resulting from prior DOD and NASA programs will be employed to the greatest extent practicable.

Additional objectives are:

- (a) Quantitative determination of man's military usefulness in space
- (b) Scientific and technological experiments of national importance
- (c) Determination of the biological responses of man in orbit for 30 days or more ~~(C-4)~~
- (d) Investigation of the possibility of operation in an unmanned mode

\*Where no heading appears with material herein defining its applicability to manned or unmanned versions, the material shall be applicable to both. As additional material within a paragraph is required for either version, a heading is provided defining the appropriate version.

~~CONFIDENTIAL~~



~~SECRET~~ SPECIAL HANDLING

1.3 Mission

The primary mission of the MOL System shall be to conduct photographic intelligence (Dorian) gathering against specific targets of interest. This MOL/Dorian system shall be herein referred to as the Dorian System. Requirements stated herein will include performance, design, development, and test. The Dorian System shall be capable of obtaining high resolution stereographic photography of specified targets. All elements and contract end items of the Dorian System shall, as a minimum, conform to the requirements delineated herein.

1.3.1 Descriptive Title

Dorian High Resolution Reconnaissance Satellite System (Dorian System).

SPECIAL HANDLING

~~SECRET~~

## 2.0 APPLICABLE DOCUMENTS (U)

Military specifications, standards, exhibits, manuals, regulations, publications, bulletins, pamphlets, and other documents are herein specified as appropriate to obtain first tier compliance for the MOL System.

The following list of applicable documents is presented for purposes of guidance. Applicability of the listed documents shall be to the extent called out in this General Specification. In cases where the requirements of the following documents are in conflict with the requirements stated in this General Specification, the General Specification shall take precedence.

A two-letter prefix code is provided to assist in associating those documents which are applicable to a particular type of specification requirement. This prefix code is indicated in the applicable sections of this specification, such as Safety, General Design and Construction Requirements, Workmanship, etc. The key to the prefix code follows:

<u>CODE</u>	<u>Paragraph Reference</u>
CV - Civil	3.2.2.4
DG - Design and Construction (Guidance only)	3.2
DR - Design and Construction Requirements	3.2.1
EE - Electrical	3.2.2.1
EI - Electromagnetic Interference	3.2.1.8
EV - Environmental Criteria	3.2.2.8
GP - Human Performance (Guidance)	3.2.2.5
HP - Human Performance (applicable)	3.2.2.5
HY - Hydraulic	3.2.2.3
IC - Interchangeability	3.2.1.6
IM - Identification and Marking	3.2.1.9
MP - Materials, Parts, and Processes	3.2.1.2
MS - Maintenance Support	3.2.2.7
SF - Safety	3.2.2.6
ST - Storage	3.2.1.10
WK - Workmanship	3.2.1.7

2.1 SPECIFICATIONS, STANDARDS, AND EXHIBITS

2.1.1 MIL Specifications

MIL-A-8421B (Para 3.1.3.5.2)	General Specification for Air Transportability Requirement, 5 May 1960
EI - MIL-B-5087B	Bonding, Electrical Lightning Protection for Aerospace Systems
EE - MIL-C-5015	Connectors, Electric, AN Type
IM - MIL-C-18012	Control Configuration and Markings
IM - MIL-C-25050	Colors, Aero Lights and Lighting Equipment, General Specification for
EE - MIL-C-26482 (Suppl 1)	Connectors, Electric, Circular, Miniature Quick Disconnect, 10 Aug 1962
DR - MIL-D-70327	Drawings, Engineering and Associated Lists
EE - MIL-E-4158E	Electronic Equipment, Ground, General Requirement for
DR - MIL-E-5400G	Electronic Equipment, Aircraft, General Specification for
EE - MIL-E-19600	General Specification for Electronic Modules
EE - MIL-E-0025366B	Electrical and Electronic Equipment and Systems, Guided Missiles, Installation, General Specification for
MP - MIL-F-007179B	Finishes and Coatings, General Specifications for Protection of Aerospace Weapons Systems, Structures and Parts

HY - MIL-H-25475A Hydraulic Systems, Missile, Design, Installation Test and Data Requirement, General Requirement for

HP - MIL-H-27894A Human Engineering Required for Aerospace Systems and Equipment

MIL-HDBK-300  
(Para 3. 2. 1. 3) Technical Information File of AGE for Air Weapon System

IC - MIL-I-8500B Interchangeability and Replaceability of Component Parts

- MIL-M-8090C  
(Para 3. 1. 3. 5. 1) Mobility Requirement, Ground Support Equipment, General Specification for

DR - MIL-M-8555 Missiles, Guided: Design and Construction, General Specification for

GP - MIL-M-26512C Maintainability Program Requirement for Aerospace Systems and Equipment, with Exceptions as Specified in Attachment 1 to SSD Exhibit 62-170

- MIL-M-38310  
(Para 3. 3. 1. 1. 1. 1) Mass Properties Control Requirements for Missile and Space Vehicles

IM - MIL-N-18307 Nomenclature and Nameplates for Aeronautical Electronic and Associated Equipment

ST - MIL-P-116C Preservation, Methods of

HY - MIL-P-5518C  
(Suppl 1) Pneumatic Systems, Aircraft Design, Installation and Data Requirement for

DR - MIL-P-9024B Packaging, Air Weapon Systems, Specification and General Design Requirement for

DR - MIL-Q-9858A Quality Control System Requirements

DR - MIL-S-852B	Handling Ground Equipment, General Requirements for
- MIL-S-8512B Para 3.1.3.5.1	Support Equipment, Aeronautical, Special General Specification for the Design of
EE - MIL-R-38100	Reliability Assurance Program for Established Reliability Parts
SF - MIL-S-38130	Safety Engineering of Systems, and Associated Subsystems and Equipment
IM - MIL-STD-130A	Identification Marking of U. S. Military Property
DG - MIL-STD-143A	Specifications and Standards, Order of Precedence for the Selection of
IM - MIL-STD-195	Marking of Connections for Electric Assemblies
EV - MIL-STD-210	Climatic Extremes for Military Equipment
IC - MIL-STD-447	Definition of Interchangeable Substitute and Replacement Items, 29 May 1962
WK - MIL-STD-454	Standard General Requirements for Electronic Equipment
DR - MIL-STD-785	Requirements for Reliability Program (for Systems and Equipments)
IM - MIL-STD-795 ✓	Colors
HP - MIL-STD-803A-1	Human Engineering Design Criteria for Aerospace System Ground Equipment
HP - MIL-STD-803A-2	Human Engineering Design Criteria for Aerospace System Facilities and Facility Equipment

GP - MIL-STD-803A-3 Human Engineering Design Criteria  
for Aerospace Vehicle Equipment  
(AVE). (If available)

EV - MIL-STD-810A Environmental Test Methods for  
Aerospace and Ground Equipment

IM - MIL-STD-1247 Identification of Pipe, Hose, and  
Tube Lines for Aircraft, Missiles,  
Space Vehicles, and Associated  
Support Equipment and Facilities

GP - MIL-T-27382 Training Equipment, Subsystem,  
Technical Data, Preparation of

EE - MIL-W-8160D Wiring, Guided Missiles, Installa-  
(Amend. 1) tion of, General Specification for

IM - MS-24123A Plate Identification

MP - MS-33586A Metals, Definition of Dissimilar

2.1.2 Air Force BMD/BSD/SSD Exhibits

IM - BMD 58-20A Gas, Fluid Line Identification

GP - BMD 59-17C Training Equipment Procurement  
for AFBM and Military Space  
Systems

IM - BMD 59-31 Color Requirement for Space  
System Ground Equipment and  
Facility Items

SSD Ex 61-47A Computer Program Subsystem  
(Para 3.3.9.2.2) Development Milestones

EI - SSD 64-4 Electromagnetic Compatibility  
SF Requirements for Manned Space-  
craft, General Specification for

EE - SSD 64-5 General Specification for Wiring  
Harness in Manned Spacecraft

GP - BMD 60-1 PSS Testing for Ballistic Missile  
and Space Systems

IM - SSD 61-70A Identification Requirements ✓

SSDL-70-1 Deleted

WK - SSD 62-117	Reliability and Quality Assurance Program Required
DG - SSD 62-128	Titan III AGE Design Requirements
DG- SSD 62-130	Facilities Requirement, General Specification
GP - SSD 62-131	PSS Requirement, General Specification
GP - SSD 62-162	Basic Data for PSS Development Specification
EV - SSD 65-7	Environmental Criteria for the MOL System
ST - SSD 62-181	Preservation to Packaging, Packing and Container Marking of Equipment, and Spare Parts for Shipment and Storage for Space/Satellite Systems
MS - SSD 63-14	Spare Parts Provisioning Requirements
DR - SSD 63-3	Engineering for Transportability

2. 1. 3 Federal Standards

IM - FED-STD-5	Standard Guides for Preparation of Item Identifications by Government Suppliers
FED-STD-222 (Para 3. 3. 2. 2. 5. 15)	Title (To be provided)
IM - FED-STD-595	Colors

2. 2 MANUALS, REGULATIONS, PUBLICATIONS

2. 2. 1 Air Force Regulations (AFR)

GP - AFR 30-8	Development of a Personnel Subsystem for Aerospace Systems
SF - AFR 32-20	Responsibilities for Explosive Safety Program
HP - 50-19	Management of Training Equipment paragraphs 1, 2, 4a(1), 5, 6, 10; all other paragraphs are GP.

IM - AFR 71-6      Preservation, Packaging, Packing,  
and Marking Policy

DG - AFR 73-1      Defense Standardization Program

IM - AFR 74-2      Identify Calibrations Requirements  
of Systems, Subsystems and  
Equipment

HP - AFR 84-7      Requirements for Contractor  
Operating Procedures and  
Flight Crews

SF - AFR 160-3      Hazardous Noise Exposure

2.2.2      Air Force Manuals (AFM)

SF - AFM 32-3      Accident Prevention Handbook

SF - AFM 127-100      Explosives Safety Manual

SF - AFM 71-4      Packaging and Handling of  
Dangerous Materials for Trans-  
portation by Military Aircraft

CV - AFM 86-8      Airfield and Airspace Criteria

DR - AFM 88-2      Definitive Designs of Air Force  
Structures

SF - AFM 127-201      Accident Prevention Handbook

2.2.3      Air Force Procurement Instructions (AFPI)

SF - AFPI 7-4047      Safety and Accident Prevention

SF - AFPI 7-4048      Safety Precautions for  
Dangerous Materials

2.2.4      Air Force Pamphlets (AFP)

MP - AFP 88-002-1      Evaluation of New Materials and/or  
Methods of Construction for Air  
Force Facilities

CV - AFP 88-009-1      Miscellaneous Instructions and  
Criteria for Design and Con-  
struction of Air Force Facilities



2.2.5 AFSC Regulations (AFSCR)

- HP - AFSCR 80-16 Personnel Subsystems Program for Aerospace, Support and Command and Control Systems (Paras. 1, 5-a-D. All other paragraphs are GP).
- MP - AFSCR 400-3 Joint Use of Contractors' In-Production Support Materials and Operational Support Spares in Selected Missile Programs

2.2.6 AFSC Manuals (AFSCM)

- DR - AFSCM 80-1 Handbook of Instructions for Aircraft Designers, Vol I, II, III
- DG - AFSCM 80-3 Handbook of Instructions for Aerospace Personnel Subsystem Designers (HIAPSD)
- DR - AFSCM 80-5 Handbook of Instructions for Ground Equipment Designers (HIGED)
- DR - AFSCM 80-6 Handbook of Instructions for AGE Designers (HIAGED)
- DR - AFSCM 80-7 Handbook of Instructions for Aerospace Vehicle Equipment Design
- DR - AFSCM 80-8 Handbook of Instruction for Missile Designers
- DR - AFSCM 80-9 Handbook of Instructions for Aerospace Systems Designers
- DG - AFSCM 81-1 Specifications and Standards Manual
- AFSCM 310-1 Deleted  
(AFLCM 310-1)
- AFSCM 375-1 Configuration Management During (All) Phase
- AFSCM 375-5 Deleted

PH - AFSCM 95-1 Deleted

2.2.7 Bulletins

EE - ANA Bulletin 400T Electronic Equipment, Aircraft & Guided Missiles, Applicable Documents, March 1963

DR - USAF Bulletin No. 515 Control of Non-Conforming Supplies

2.3 OTHER DOCUMENTS

IM - AFLCM 65-3 (Part IV) Source and Maintenance Coding USAF Aeronautical and Supporting Equipment

MP - ASPR 7-105.7 Material Inspection and Receiving report "DD Form 250"

MS - DCAS Exhibit 61-87 Weapon System/Equipment Operations and Maintenance Records

DG - DOD Manual 200A Defense Standardization Manual

SF - ICC Tariff No. 15 Requirements for Transport of Explosives

CP -- NASA Life Science Data Book

EE - NEC National Electric Code - 1959

MS - T. O. 33-1-14 Repair, Calibration and Certification of Precision Measurement Equipment

GP - WADC TR52-321 Anthropometry of Flying Personnel, 1950 dated Sept. 1954

DG -- Department of Defense Index of Specifications and Standards, Parts 1, 2, and 3

DG --	Meteorological Note No. 2, Atmospheric and Wind Design Criteria for PMR, Titan IIIX/Agna, by Martin Company/Denver, dtd 7 August 1964
-- -- (Para 3.3.2.2.9.2)	Structural Criteria for the Manned Orbiting Laboratory (MOL) Laboratory Vehicle System
SSBD 65-22	Titan IIIM System Performance/ Design Requirements, General Specification 12 November 1965
No. 250-649-1 (Para 3.3.2.2.6.2.8)	U. S. Navy Submarine Atmosphere Habitability Data Book, Rev 1, Navy Bureau of Ships
AFWTR 550-2	WTR Range Safety Handbook
SSDM 80-1	Flight Test Documentation Manual
AFBSD TR62-2	Storable Propellants Handbook
SSMD-77 (Security Control No. only) Para 3.1.1.1.10	Government Plan for Program Management for the MOL

**SPECIAL HANDLING**

~~SECRET~~

2.4 Dorian Exceptions to Applicable Documents Listing

The following additions/deletions comprise exceptions to the foregoing list of documents applicable to the Dorian mission payload.

a. Additions

MIL-STD-150A Photographic Lens

b. Deletions

**SPECIAL HANDLING**

~~SECRET~~

~~SECRET~~

3.0

REQUIREMENTS

3.0.1

General (~~S-3 SAR~~)

The Manned Orbiting Laboratory (MOL) Program centers around an orbiting vehicle used to carry out military and scientific programs for durations of 30 days. The Orbiting Vehicle (OV) shall be launched by a MOL Titan III from Vandenberg Air Force Base (VAFB).

The on-orbit tasks for the MOL system shall provide for both manned and unmanned operation of the Laboratory Vehicle and the Mission Payload Segments. During manned operations, equipment in general will be operated automatically with crew monitoring and manual override capability. Provisions shall be made for conversions of the Orbiting Vehicle for complete unmanned operation within a 4-month pre-launch period, utilizing appropriately packaged hardware and software elements. Provisions shall be made for disposal of the Laboratory and Mission Payloads upon completion of the mission.

The MOL System is specified in terms of system segments as defined in paragraph 3.1.2.2.

Manned Version

The Orbiting Vehicle (OV) consists of a Laboratory Vehicle, a Mission Payload and a modified Gemini spacecraft (Gemini B). During the ascent to orbit, the flight crew will be in the Gemini B. After achieving orbit, the crew will transfer to the Laboratory Vehicle to perform the on-orbit tasks as programmed. Orbital operations shall be planned to enable evaluation of the relative performance and effectiveness of the automatic and manual modes of operation. At the end of the mission, the crew will return to the Gemini B, separate the Laboratory Vehicle from the Gemini B, de-orbit and re-enter, and be recovered.

Unmanned Version

When configured for unmanned operation, the Gemini B will be replaced with a nose cone housing a support module.

3.0.2

Performance (~~S-3 SAR~~)

The MOL flights shall be conducted from a Titan III Initial Launch Capability (ILC) at VAFB. Orbiting Vehicle operations involving attitude control, translational control and separation of vehicle elements shall be capable of being conducted either with crew or automatically. Retrofire and

~~SECRET~~

~~SECRET~~

re-entry shall be performed under pilot control. All system designs and trade-offs shall reflect both modes of operation. The Basic MOL design decisions should not preclude possible extension of stay in orbit, using integral launch. The basic MOL design decisions should not preclude in-space rendezvous.

#### Manned Version

Upon achieving orbit, the flight crew (located in the Gemini B during launch and injection into orbit) will prepare to transfer to the Laboratory Vehicle by conducting a checkout of the essential Laboratory subsystems from the Gemini B. Upon entering the Laboratory, the flight crew shall activate the remaining Laboratory subsystems to place the Laboratory Vehicle in a full-operating condition. The flight crew shall be the primary source of on-orbit flight decisions.

Flight crew functions will include performance of prescribed mission tasks, observations, physiological testing, and the monitoring, controlling, and maintenance of vehicle and mission subsystems. Status of subsystems in the Gemini B essential to safe return will be monitored. Mission data, as well as telemetry of OV condition and flight crew physiological functions, shall be transmitted from the OV to ground stations and/or recorded on board as appropriate for transfer to the Gemini B and return to earth. Data return by capsule shall be used as appropriate.

Communications with the on-orbit flight crew, and mission control functions will be performed from Mission Control. A network of tracking and data acquisition stations will provide world-wide communications coverage. Certain mission functions will be accomplished by an on-board central general-purpose digital computer. Over-all control of the various tasks will remain a flight crew function for manned operations. Automatic control will be exercised by the AVE Computer and Mission Control as appropriate. Provision shall be made for flight crew override for flight or mission emergencies. Certain analyses shall be made during orbital flights both on-board and on the ground, additional analysis will be performed after data recovery.

Upon completion of the mission, the flight crew shall perform final checks of the condition of the Gemini B spacecraft and activate those systems required for flight crew transfer. The crew shall deactivate certain subsystems in the Laboratory Vehicle and return to the Gemini B for separation

~~SECRET~~

~~SECRET~~

and re-entry. Upon return of the flight crew to the Gemini B, checkout and activation of subsystems associated with life support, separation, control, and re-entry will be completed and verified by the ground network.

Upon completion of all systems checkout and verification, separation shall be effected and de-orbit and re-entry accomplished. Following re-entry into the atmosphere, the Gemini B will display a parachute system for descent to a water recovery site where ship/aircraft recovery forces will recover the flight crew, Gemini B, and mission data. The planned and alternate end-of-mission recovery areas will be located near the continental U.S., and all contingency recovery areas will be located as close as possible to the U.S. or to U.S. controlled territories.

Provision shall be made for continued operation of the Laboratory and Mission Payload Segments in the unmanned mode after separation of the Gemini B for crew return. Disposal of the laboratory and mission payload segments will be accomplished from Mission Control upon the completion of operations.

Unmanned Version

On-orbit operations will be controlled by the AVE computer and mission control.

3.0.3

Growth Considerations

(later)

~~SECRET~~

~~SPECIAL HANDLING~~

~~SECRET~~

54

### 3.0.4 Mission Requirements

#### 3.0.4.1 Photographic Resolution

It is required that a resolution of [REDACTED] be obtainable with the Dorian System. Consideration must also be given to growth to advanced optical systems, so that resolutions on the ground [REDACTED] may be obtained.

Unless otherwise noted in this specification, a statement of ground resolution shall be under the following conditions: Type S0-362 film, on-axis, nadir position, 2-sigma focus and smear, 2:1 contrast ratio at the vehicle, 890 foot-lamberts scene luminance, 80 n.mi. altitude. The Dorian System shall be capable of [REDACTED] resolution under these conditions for launches between 21 March and 22 August for targets at latitudes as high as 50°N and for mission durations of 30 days.

For design purposes, a minimum of 1500 cloud-free targets per 30-day mission shall be considered the requirement for the Dorian System, for a cloud-cover of 60 percent (i.e., 60 percent of prospective targets are cloud-covered during the 30-day mission).

#### 3.0.4.2 Target Access

It is a design goal that complete photographic access shall be provided above 30°N latitude at least four times during a 30-day mission. Access shall not require an obliquity angle greater than +40 degrees. The system shall be capable of photographing any cloud-free location in the world having a sun angle greater than 5 degrees while the vehicle is traveling on either a northbound or southbound orbital pass.

### 3.0.5 Secondary Mission Requirements

Development and demonstration of other military applications of the Dorian System are to be considered as secondary mission requirements of the system. To achieve secondary mission requirements, vehicle design parameters shall not be prescribed in such a way as to compromise the primary mission requirements.

~~SPECIAL HANDLING~~

~~SECRET~~



~~SECRET~~

3.1 PERFORMANCE CHARACTERISTICS

3.1.1 Performance Characteristics - General (U)

Performance characteristics of the MOL system are defined in terms of System Characteristics, Logistics, and Personnel and Training.

3.1.1.1 System Characteristics (U)

The significant system characteristics are basically defined in terms of the various phases ranging from pre-launch through mission evaluation, the location at which these shall be accomplished, and the responsibilities for the various portions of the mission.

3.1.1.1.1 Pre-launch Phase (S-4)

This phase covers the period from arrival of systems at the MOL Launch Site (MLS) to the start of countdown on the launch pad. Assembly of the OV to the Launch Vehicle will take place at the launch pad for checkout and final countdown. The segments of the Launch Vehicle will also be brought to the launch pad for assembly and checkout prior to being mated to the OV. The system shall be capable of meeting a launch frequency requirement of one flight every \_\_\_\_\_ months. The system shall be designed so that conversion from manned to unmanned or from unmanned to manned versions shall not require more than four months.

3.1.1.1.1.1 Launch Window (S-3 SAR)

The MOL System shall be capable of launching within a one hour window on a day specified two weeks in advance with a probability of 0.75 for that day and for each of the two following days. This probability value does not include delays resulting from non-technical constraints. Placement of the over-all launch window within a 24 hour period shall be determined by:

- 1) Mission requirements and priorities
- 2) Vehicle constraints

3.1.1.1.1.2 Solar Angle (S-3 SAR)

The solar angle ( $\beta$ ) shall be between -60 deg and +60 deg. The angle beta is defined as the angle between the earth-sun line and the orbital plane.

~~SECRET~~

~~SECRET~~

3.1.1.1.2 Launch Phase (U)

This phase covers the period from initiation of countdown on the launch pad through lift-off.

3.1.1.1.2.1 Flight Crew Launch Occupancy (C-4)

The time to launch a Flight Vehicle after the flight crew enters the Gemini B shall be as short as possible, not exceeding 120 min, including scheduled countdown sequence holds other than the 60-min hold at T-10 min of paragraph 3.1.1.1.2.2 below.

3.1.1.1.2.2 Hold Time (C-4)

Holds may be used to meet an optimum launch time, within the specified window, dependent upon:

- 1) Mission requirements and priorities
- 2) Evaluation of the confidence in ability to hold for the required time.

The MOL System shall provide for up to a 1-hr hold at T-10 min.

3.1.1.1.2.3 Flight Crew Pre-Launch Egress (C-4)

Prior to lift-off, escape from the Flight Vehicle in the event of an emergency shall be by egress from the flight crew hatch or by means of the pad abort escape system at the discretion of the crew or by pre-arranged procedures.

3.1.1.1.2.4 Turn-Around Time Following Scrub (C-4)

Following a scrub during the countdown, the MOL System shall be capable of launch at the opening of the launch window on the next day with the only deviation being the repair time on failed non-replaceable subsystems/components. (Subsystems/components are not considered replaceable for the purposes of this requirement if de-fueling is required prior to replacement.) If de-fueling is required to repair/replace a failed subsystem/component, the MOL system shall be capable of launch within the launch window on the third day following the scrub.

~~SECRET~~

~~SECRET~~

3. 1. 1. 1. 2. 5 Back-up Launch Capability (~~C-4~~)

Design of the Launch Operations, Facilities, Flight Operations, and Test Support Segments of the over-all MOL system shall not be such as to preclude the future incorporation of capability to achieve a back-up launch within a 30-day period following determination of the requirement for such a launch. Design considerations to support the requirement shall be based upon the assumption that flight hardware can be made available for launch site integration and checkout in time to support the back-up launch.

3. 1. 1. 1. 3 Ascent Phase (~~C-4~~)

This phase covers the period from lift-off through insertion into an initial sustainable orbit and confirmation thereof.

3. 1. 1. 1. 3. 1 Azimuth (~~S-3 SAR~~)

The system shall be capable, as a minimum, of launching a mission from Vandenberg Air Force Base (VAFB) at launch azimuths such as to achieve any orbit inclination between 80 and 100 deg, as specified in paragraph 3. 1. 1. 1. 3. 3, including the use of yaw maneuvers if required by range safety regulations. Launch azimuth capability compatible with the 65 to 125 deg orbital inclination stated in paragraph 3. 1. 1. 1. 3. 3 is also a design goal herein.

3. 1. 1. 1. 3. 2 Trajectory Safety (~~C-4~~)

The ascent trajectory shall be such that, in the event of mission abort at any time, the Gemini B will not exceed safe conditions for re-entry and recovery or the Gemini B will be in an orbit from which normal re-entry can be made at a later time.

3. 1. 1. 1. 3. 3 Orbital Inclination (~~S-3 SAR~~)

Operation in all orbital inclinations between 65 deg and 125 deg shall be achievable as a design objective for the OV. Inclinations between 80 deg and 100 deg shall be achievable as a basic requirement.

~~SECRET~~

~~SECRET~~

3.1.1.1.3.4      Insertion Conditions (~~S-3 SAR~~)

Insertion shall be performed by the Launch Vehicle into an initial orbit with a minimum perigee of 70 n. mi. located between 30° - 50° N latitude.

It shall be possible to alter insertion parameters as late as three days prior to a scheduled launch, provided the changes do not exceed the redeployment capability of the downrange elements.

3.1.1.1.3.5      Communication (~~S-4~~)

The system shall provide voice communication between the flight crew in the Gemini B and Mission Control during all portions of powered ascent.

3.1.1.1.3.6      Flight Crew Safety (~~C-4~~)

Crew safety during the ascent phase shall be provided by the inherent safety of the MOL Flight Vehicle and the abort/escape system of Gemini B. The probability of a crew fatality during powered ascent shall be no greater than 0.0003.

3.1.1.1.4      Early Orbit Phase (~~C-4~~)

This phase begins after insertion and ends when the flight crew has shut down the Gemini B and has transferred to the Laboratory Vehicle.

3.1.1.1.4.1      Orbit Adjust (~~S-3 SAR~~)

Orbit adjust is the transfer from the initial sustainable orbit, or any orbit, to any subsequent orbit. Orbit adjust shall be accomplished by providing the required  $\Delta V$  from the Laboratory Vehicle Attitude Control Translation System (ACTS). See 3.3.2.2.7.8.3

3.1.1.1.4.2      Orbital Altitude (~~S-3 SAR~~)

The MOL system shall be capable of achieving any orbit, circular or elliptical, within the limits defined in Figure 3-1. The extreme boundaries of the required operating altitudes and required inclinations shall be achievable from the combination of the booster velocity and the velocity achieved from ACTS operation.

3.1.1.1.4.3      Flight Crew Transfer (~~S-4~~)

Passage of the flight crew between the Gemini B and the Laboratory Vehicle shall normally be accomplished within a pressurized tunnel. Capability for extravehicular crew transfer will be provided as a back-up mode.

~~SECRET~~

~~SECRET~~

3.1.1.1.5 On-Orbit Phase (U)

This phase covers the period from insertion until separation of the Gemini B from the Laboratory prior to the initiation of re-entry.

3.1.1.1.5.1 Duration (C-4)

The nominal MOL System OV mission duration shall be 30 days.

3.1.1.1.5.2 Nominal Orbiting Vehicle Orientation (C-4)

The OV shall be nominally oriented such that the longitudinal axis is aligned with the orbital plane, with Gemini B forward, and perpendicular to the local vertical. As an alternate mode, the longitudinal axis will be aligned with the relative velocity vector (Ref. Paragraph 3.3.2.2.7.2.1) and the local vertical.

3.1.1.1.5.3 Orbit Maintenance (S-3 SAR)

The perigee shall be no less than 70 n. mi. throughout the on-orbit phase of the mission.

3.1.1.1.5.4 Abort (C-4)

The system shall be capable of evacuating the MOL flight crew in the event of an on-orbit mission abort and of returning the crew to preselected water landing sites. The abort procedure shall be initiated and accomplished by the flight crew.

3.1.1.1.5.5 Checkout and Monitoring (U)

The Orbiting Vehicle shall contain equipment capable of providing information relative to the operation of vehicle systems and well-being of the flight crew. These data shall be available to the flight crew on-orbit and to the Mission Control via the ground network. The data available on-orbit shall be of a form that allows easy recognition of parameters critical to flight crew safety, mission status, and Orbiting Vehicle equipment status. Recognizable visual and auditory warning devices shall be provided for critical parameters.

The status of critical Gemini B subsystems shall be available to the flight crew during the on-orbit phase.

3.1.1.1.5.6 Flight Crew Transfer

(now Paragraph 3.1.1.4.3)

3.1.1.1.5.6 Mission Operations (S-3 SAR)

The equipment shall be operable by flight crew members. The equipment design for the segments listed below shall be such that the crew time allocations shall not be exceeded in normal operations.

~~SECRET~~

~~SECRET~~

	<u>Maximum Average Hr/Day</u>
Mission Payload	16.0
Laboratory Vehicle	4.0
Gemini B (Monitoring)	0.25
Crew (Eat/Sleep/Arousal/ Conditioning/Personal/ Equipment)	24.0
	<hr/>
TOTAL initial Allocation	44.25

The equipment shall be designed for remote operation from Mission Control with provisions for monitoring both by Mission Control and by the flight crew during automatic operation. For automatic operation, mission vehicle operations may be programmed for duty cycles in excess of those given in the above table to provide additional data. If this is done, crew activities may be appropriately scheduled to permit operation (monitoring) in accordance with that schedule.

3.1.1.1.5.7 Maneuvering (C-4)

The OV shall have three axis attitude control and attitude maneuver capability. It shall also have the capability of providing linear acceleration in the direction of the longitudinal axis.

3.1.1.1.6 Re-entry Phase (U)

Re-entry is defined as the period commencing with separation of Gemini B from the Laboratory and ending with landing. This phase

~~SECRET~~

includes loiter time, retro-fire, de-orbit, parachute deployment, and touchdown. Loiter is defined as a mode during which the Gemini B operates as an autonomous spacecraft separated from the Laboratory; this separation is required in the event of a failure of a critical Laboratory system.

3. 1. 1. 1. 6. 1      Separation (U)

The Gemini B shall be capable of separation from the Laboratory Vehicle only by flight crew initiation from the Gemini B.

3. 1. 1. 1. 6. 2      Communications (U)

During re-entry, recovery aids (including a beacon) shall be provided in the re-entry module to facilitate tracking and touchdown prediction. A voice communication link shall be provided.

3. 1. 1. 1. 7      Retrieval Phase (U)

Retrieval operations start with the re-entry module touchdown prediction and end when the crew, data, and re-entry module are recovered and returned to predetermined locations for the initiation of post-flight analyses. Retrieval includes location of the re-entry module, physical recovery of the re-entry module, crew, mission data, an initial medical examination, and initial de-briefing of the crew. Communications and location aids shall be provided for use during this phase.

3. 1. 1. 1. 7. 1      Recovery Support (U)

Recovery forces consisting of land, sea, and air units equipped with proper gear to facilitate recovery of the flight crew, re-entry module, and data shall be provided.

3. 1. 1. 1. 8      Performance Evaluation (U)

Mission performance evaluation shall include: evaluation of flight crew performance, evaluation of on-orbit equipment (both vehicle and mission equipment), and evaluation of over-all mission operation including pre-launch and launch operations.

~~CONFIDENTIAL~~

3. 1. 1. 1. 9      Operating Locations

3. 1. 1. 1. 9. 1      Acceptance Tests (~~C-4~~)

All contractor AVE equipment shall be assembled and acceptance-tested at the respective responsible contractors' facilities prior to shipment to either VAFB or to the Laboratory Vehicle contractor's facility, as appropriate. Those system elements of the Orbiting Vehicle which are supplied to the Laboratory Vehicle contractor as GFE shall be installed at the Laboratory contractor's facility for integration tests. (See Fig. 3-4.)

3. 1. 1. 1. 9. 2      Pre-Launch Integration, Checkout, and Launch (~~C-4~~)

Following receiving, inspection, and assembly of various equipment items at the OV Assembly Building, final assembly of the MOL System Flight Vehicle will be completed at the launch area. The Flight Vehicle will be checked out and launched from the Western Test Range.

3. 1. 1. 1. 9. 3      Mission Operations

3. 1. 1. 1. 9. 3. 1      Mission Control (~~C-4~~)

Mission Control shall be at the Satellite Test Center in Sunnyvale, California, and will exercise centralized control over all aspects of the mission.

3. 1. 1. 1. 9. 3. 2      Tracking and Communication Sites (~~C-4~~)

Tracking and communication network stations are designated by the phase of the mission profile during which they operate. The stations chosen for each phase are as follows:

- (1)      Ascent
  - WTR/Point Arguello
  - PMR/San Nicholas
  - PMR/Point Mugu
  - NRD Ships
  - SCF/VAFB

~~CONFIDENTIAL~~



~~CONFIDENTIAL~~

(2) Early Orbit

SCF stations  
Selected NASA stations  
Selected ETR stations  
Selected WTR stations

(3) On-Orbit

SCF stations  
Selected NASA and ETR stations

3. 1. 1. 1. 9. 4 Recovery Areas (~~C-4~~)

Recovery ships and aircraft will be placed in areas so located as to provide a number of supported recovery opportunities each day. There will be a supported recovery capability for each of the first three orbits (in addition to launch abort recovery zones) and a supported recovery capability for about once every 12 hours thereafter. All recovery areas will be near the continental U. S. or U. S. controlled territories.

3. 1. 1. 1. 10 Mission Responsibilities (U)

Mission responsibilities are as defined in the Government Plan for Program Management for the MOL, SSMD-77 (Security Control number only).

3. 1. 1. 2 Logistics

3. 1. 1. 2. 1 Supply Support (U)

Spare parts support for the Laboratory Vehicle, Gemini B, Mission Payloads, and associated AGE shall be provided in accordance with SSD Exhibit 63-14 dated 15 Nov 63 and its Amendment #1 dated 14 Apr 65. Spare parts requirements shall be based on a concept of minimum maintenance at launch site by component replacement.

3. 1. 1. 2. 2 Maintenance Support (U)

All levels of maintenance for the Laboratory Vehicle, Mission Payload, Gemini B, and associated AGE shall be vested with the respective

~~CONFIDENTIAL~~

3-13

~~CONFIDENTIAL~~

responsible contractors. Maintenance considerations in support of the Laboratory Vehicle, Gemini B, and its AGE should be principally confined to the removal and replacement of modules/components. Maintenance facilities available at the launch site will not be duplicated when existing facilities can be made available for program utilization.

3. 1. 1. 3            Personnel and Training

Deleted

3. 1. 1. 3. 1        Operational Personnel

There are no Operational Personnel for MOL in the general military sense except as included in the support functions. Support personnel associated with flight operations will be assigned and/or coordinated by the MOL System Program Office. Personnel required for the assembly, checkout, maintenance, launch, and operations support shall be supplied and trained by contractors concerned with the various system segments.

~~CONFIDENTIAL~~

~~SECRET~~

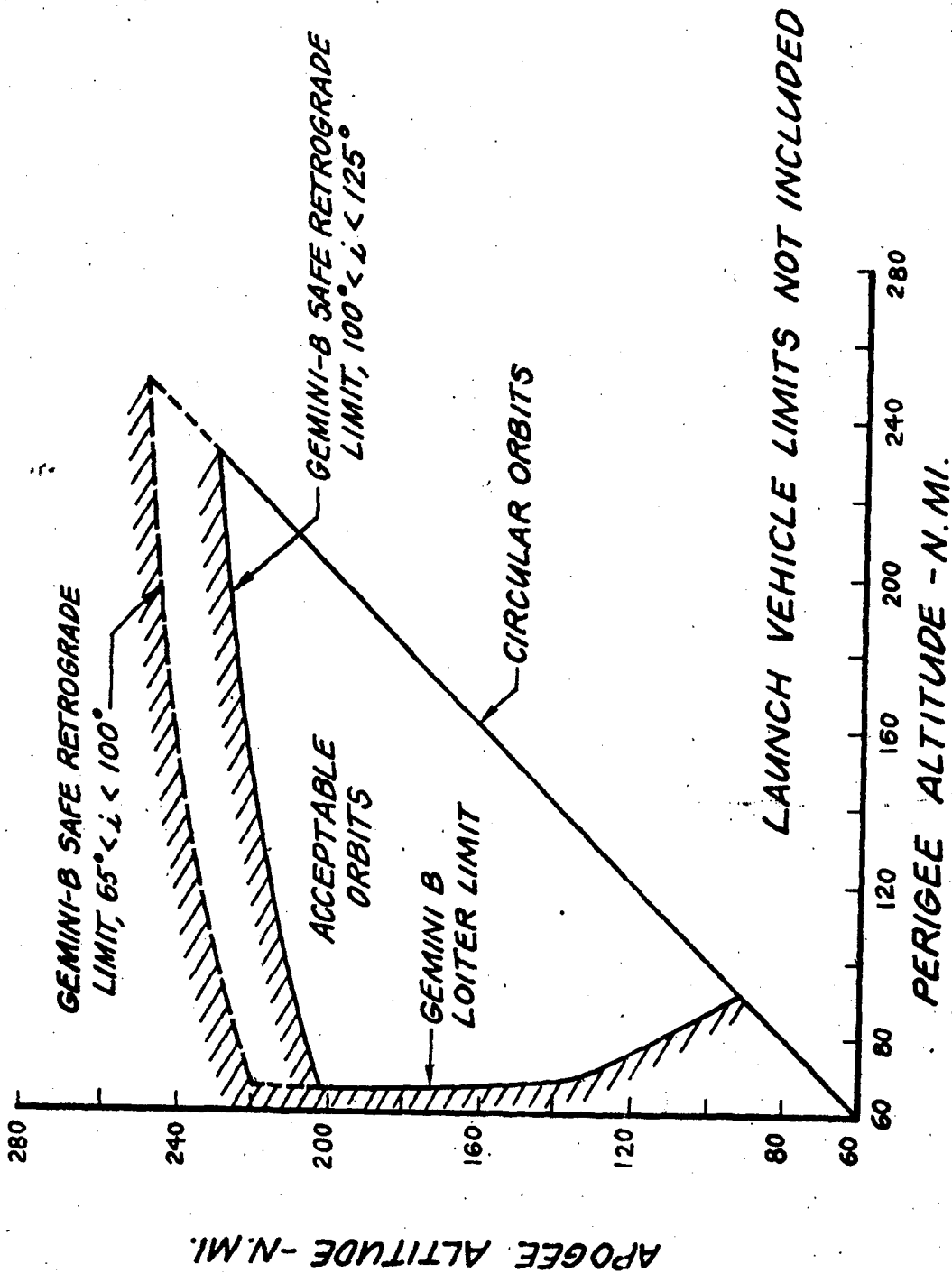

Figure 3-1. MOL Orbiting Vehicle Segment Orbit Altitude Constraint

~~SECRET~~

3-15/16

~~SECRET~~

SPECIAL HANDLING

3.1.1.4 Mission Characteristics

3.1.1.4.1 Target Selection Capability

Target selection shall be made by command decision and ground data processing considering priority of targets, weather, and the time required to complete a given target relative to accessibility of succeeding targets. During manned operations, the crew will have the capability of making final target selection (e.g. select an alternate target rather than a primary target because of weather considerations). It is desirable that ground data processing have the capability of minimizing photography of cloud obscured (in preference to cloud free) targets.

3.1.1.4.2 Data Retrieval

*Manned* - Automatic Configuration

The system shall be capable of processing and returning data from the exposed film and returning the exposed film itself. Three methods of data retrieval shall be used: (1) Data selected by the astronauts, processed and transmitted over a wideband readout link to the ground facilities. Security considerations dictate a cryptographic link for this data transmission. (2) Exposed film returned by a Data Re-entry Vehicle. (3) Exposed film returned with the astronauts in the Gemini B.

Automatic Configuration

Film will be returned periodically by Data Re-entry Vehicle.

3.1.1.4.3 Command and Control

The system shall have the command and control capability required to obtain photographs of the maximum number of clear targets from the target list. Radio contact with the ground is permitted as a portion of the command and control, as well as for purpose of tracking and telemetry.

*Manned* - Automatic Configuration

The command and control capability shall use a crew of two astronauts in a manner consistent with the requirement to reserve the

~~SECRET~~

SPECIAL HANDLING

~~SECRET~~

astronauts for functions for which they are especially and uniquely qualified. The system shall be capable of operation by a single astronaut with minimum degradation to system performance.

3.1.1.4.4 Mission Orbital Envelope

The Orbiting Vehicle must be capable of operating over the apogee and perigee intervals for the orbital inclinations shown in Figure 3.1-1. The maximum altitude for photography shall be 230 n.mi.

Photography will be conducted over the area of interest at sun elevation angles at the target ( $\eta$ ) as small as five degrees. Sun illumination required for high quality photography defined by this specification is 890 ft lamberts, which corresponds to a sun angle of approximately 40 degrees.

Orbital parameters for the Dorian mission shall optimize the optical resolution and target access as given in Section 3.0.4.2, within the sun angle constraints as stated above and in Section 3.1.1.1.2.

3.1.1.4.5 Quick Launch Reaction

The capability shall exist to launch within the orbit envelope shown in Figure 3-1.1, with notice of nominal lift-off time and selected orbit parameters for the given mission \_\_\_\_\_ days prior to this nominal lift-off time. The system shall have the capability of responding to a new target list, based on unchanged orbital parameters, as late as \_\_\_\_\_ hours prior to launch.

3.1.1.4.6 Resolution

The resolution achievable at zero stereo angle by the system as a function of obliquity and illumination must be no worse than that shown in Figure 3-1.2. The specified ground resolution includes the dynamic resolution loss due to all contributions to smear.

Across-the-format IMC corrections shall be provided so that the loss in resolution anywhere within  $0.8^\circ$  diameter circle about the center of format from the resolution achievable at the center for format shall be no greater than that given by Figure 3-1.3.

SPECIAL HANDLING

~~SECRET~~

~~SECRET~~

SPECIAL HANDLING

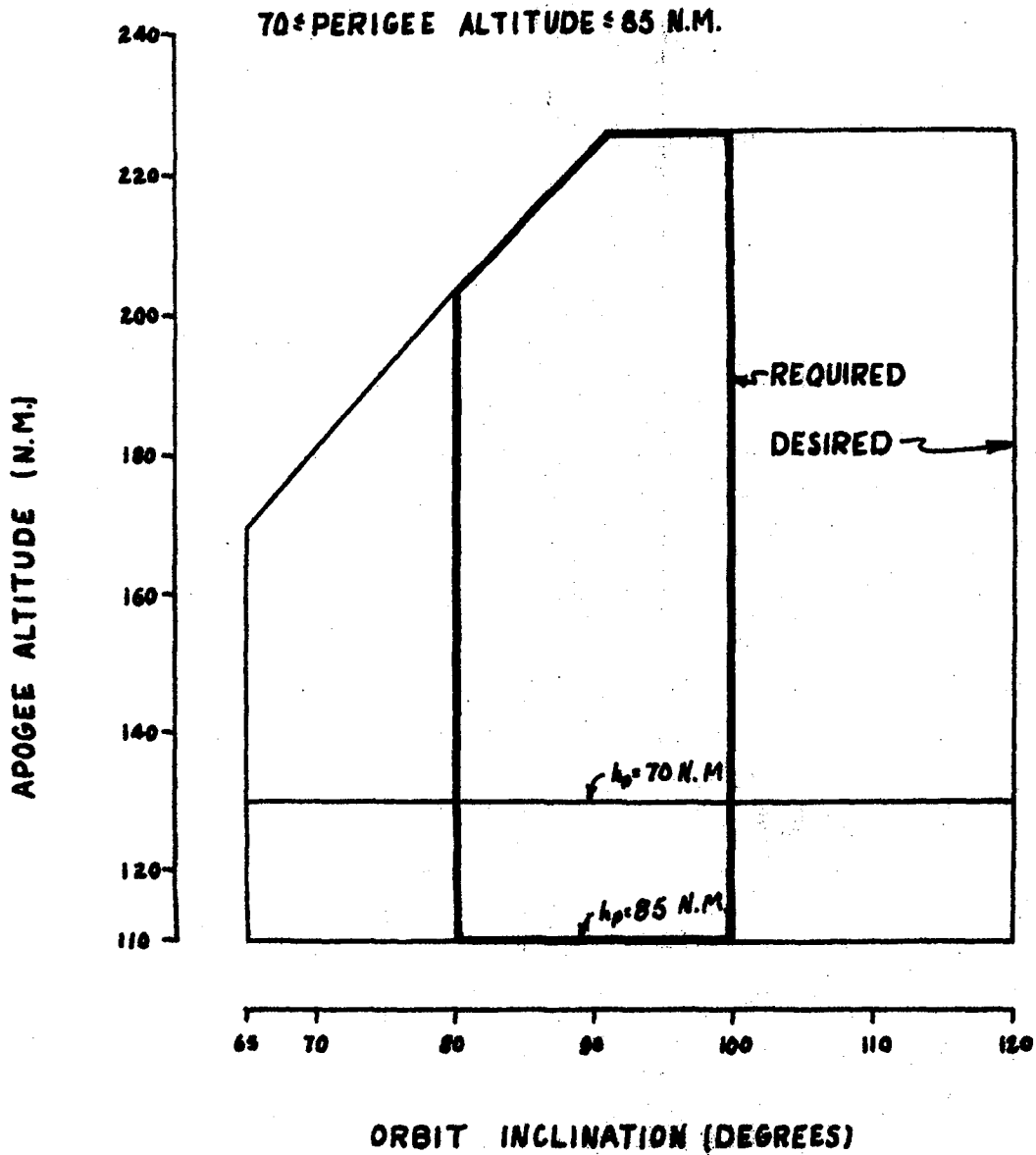

Figure 3-1.1 Orbit Envelope

~~SECRET~~

SPECIAL HANDLING

SPECIAL HANDLING

~~SECRET~~

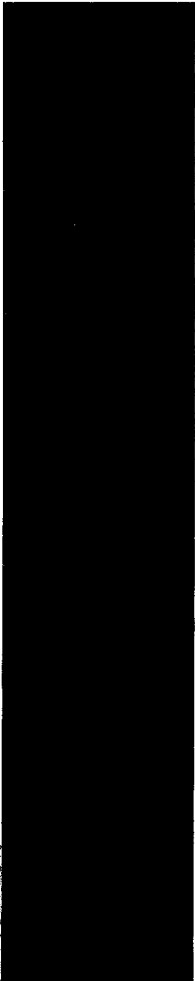
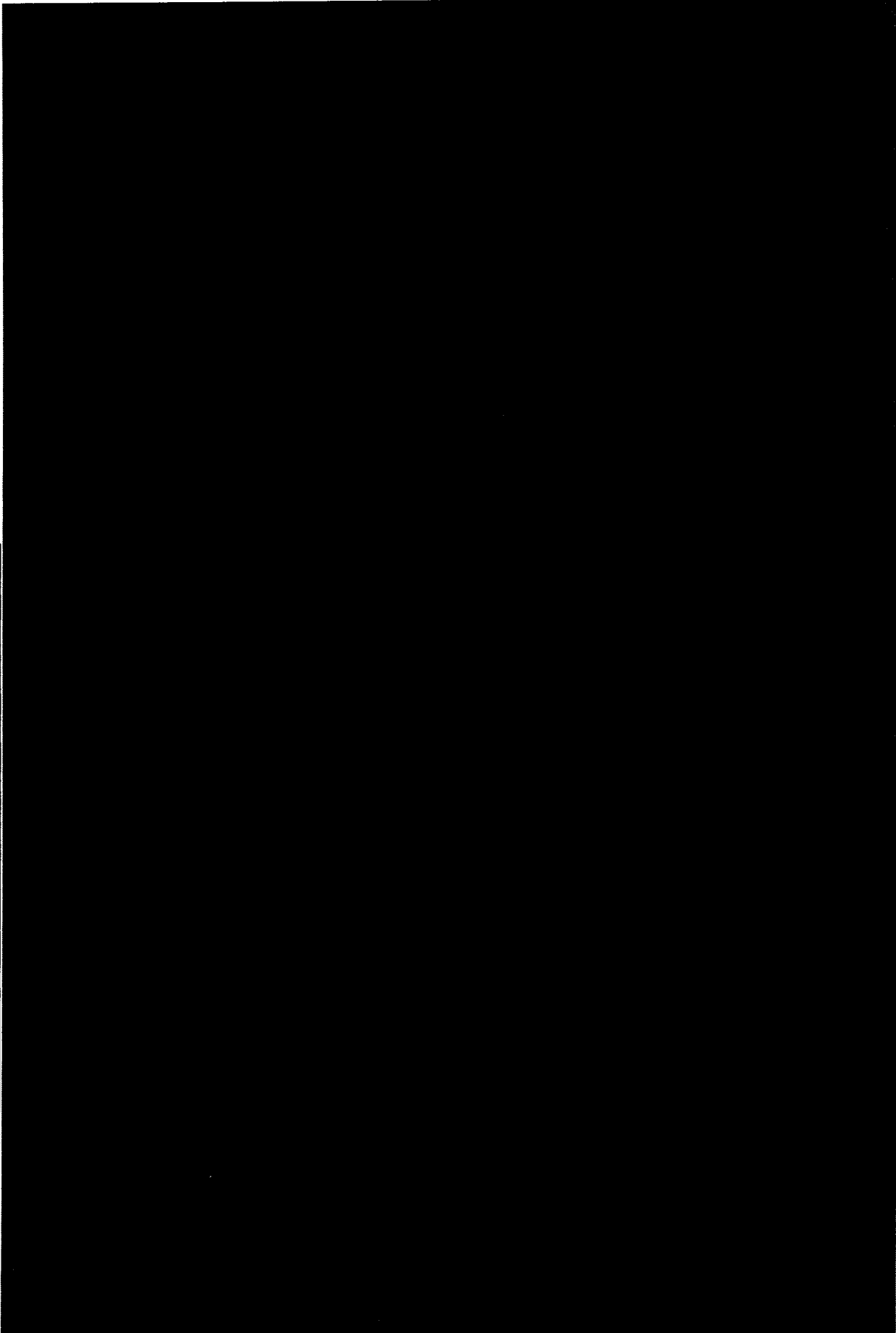

NRO APPROVED FOR  
RELEASE 1 JULY 2015

~~SECRET~~

**SPECIAL HANDLING**

~~SECRET~~

Figure 3-1.3

Across the Format IMC

(later)

**SPECIAL HANDLING**

~~SECRET~~



~~SPECIAL HANDLING~~

~~SECRET~~

3.1.1.4.7 Smear Limits

In addition to the resolution specification, it is required that the amount of smear appearing on the format be limited to a maximum acceptable value.

*manuscript* Automatic Configuration

It is assumed that the astronaut contribution to rate control will allow the system to meet this value. However, in order for the astronaut to perform properly in this function within reasonable time constraints, the smear contribution provided by the system exclusive of the astronaut participation in rate control must also be limited. The total smear contribution to dynamic resolution loss in terms of angular rate shall not exceed the following values at the center of format:

- a. With astronaut participation in rate control:  
[REDACTED] radians/second ( $2\sigma$ )
- b. Exclusive of astronaut participation in rate control:  
[REDACTED] radians/second ( $2\sigma$ )

The uncompensated image smear due to vibration shall be no greater than [REDACTED] radians/second ( $2\sigma$ ).

Automatic Configuration

The total smear contribution to dynamic resolution loss in terms of angular rate shall not exceed [REDACTED] radians per second. The uncompensated image smear due to vibration shall be no greater than [REDACTED] radians per second.

3.1.1.4.8 Data Reconstruction

For reconstruction of ground detail and object location it is required that attitude and time information be included on the film edge. Edge data are discussed in detail in section 3.3.4.5.6.

3.1.1.4.9 Orbital Reaction Times

While in orbit, the system shall be capable of reacting to changes in the target list received by the Satellite Test Center at Sunnyvale, California, one-half hour or more before a command loading opportunity where these changes do not require a change in orbit parameters.

~~SPECIAL HANDLING~~

~~SECRET~~

~~SECRET~~ SPECIAL HANDLING

3.1.1.4.10 Astronaut Requirements (<sup>manned-</sup> Automatic Configuration)

The major astronaut contributions required for commands and control consist of:

a. Selection of Targets

In the presence of cloud cover which is not 100 percent, the astronauts will select the least obscured target from the primary and alternate targets.

b. Reduction of Tracking Error

Two acquisition and tracking scopes will be provided. By acquiring and tracking the next target while photography of the current target is occurring and being monitored (or controlled) by one of the two astronauts, the other astronaut will observe that the tracking error for the next target is reduced to a minimum by the time the target becomes current. At the time a target becomes current, the tracking error will be slewed to the target. One astronaut may then observe that the tracking error is nulled in position and rate while observing the target through the main optics.

c. Cluster Photography

The capability shall be provided to photograph the targets of a cluster in the following manner. The first target will be acquired at a forward stereo angle and the image motion will be stopped by the astronaut. The camera will then automatically step through the other targets of the cluster, taking one photograph of each at a forward stereo angle. The computer will provide precise angle rates for succeeding targets, based on the astronaut-controlled rates obtained for the first target. This entire procedure will be repeated to provide one photograph of each target at an aft stereo angle. (See 3.5.3.4.7)

d. Photographic Results

The astronauts will compile information on the results of the photography for each target. This information will be furnished to the ground facility controlling target selection.

e. Data Readout Editing

Generally, only a portion of selected photographic frames will be read out. The astronauts will select that portion.

f. Verbal reporting of visual observations or photographic interpretation of selected high priority target information.

~~SECRET~~ SPECIAL HANDLING

**SPECIAL HANDLING**

~~SECRET~~

3.1.1.4.11 De-orbit Dorian System Hardware

A capability to de-orbit the Dorian System hardware into designated water impact areas at termination of orbital operations shall be provided.

3.1.1.4.12 Security of Operations

Provisions shall be made for interfacing technical personnel (e.g., EK personnel) in support of checkout, launch, and orbital operations so that maximum support can be provided without compromising Dorian security requirements. In addition, the ground-vehicle communication system must be designed for efficient communications without compromising Dorian security requirements.

**SPECIAL HANDLING**

~~SECRET~~

3. 1. 2            System Definition

3. 1. 2. 1        System Engineering Documentation

3. 1. 2. 1. 1    MOL System Top Level Functional Flow Diagram

The MOL System Top Level Functional Flow Diagram (Fig. 3-2) contained in this System Specification is the starting point for system engineering of the MOL System and is arranged to facilitate integration of system engineering activities. Each block of the diagram represents a functional area which has special interest to one of the Associates (contractors or participating government agencies). This contractor/ agency (in parentheses just above each block of the Top Level Flow Diagram) is assigned responsibility for intermediate integration of system engineering data of Associates making contributions to the functions contained in the block.

Intermediate integration is accomplished by first developing, in cooperation with the contributing Associate contractors/agencies, the necessary lower level flow diagrams for the functions of the block which clearly divide the task responsibilities among the Associates, and supplying them to the Contributing Associates. Each Contributing contractor/agency then prepares the system engineering data for his part of the system and delivers it to the designated Intermediate Integrator for integration to assure compatibility. The data packages which result from this process are then integrated for over-all system compatibility by the Laboratory Vehicle Contractor acting as the Over-all System Integration Contractor. All steps in this process will be monitored by the MOL SPO and periodic formal reviews will be held to determine status and progress.

3. 1. 2. 1. 2    MOL System Flow Diagram Code

The code system for identification of the blocks in the MOL system functional flow diagrams is shown in Figure 3-3. Each block designator consists of an alpha-numeric code which identifies: (1) the

mission, (2) the participating Associate responsible for preparing the block, and (3) the area in which the activity is conducted. In addition, each block will contain an identification number as shown in Fig. 3-2:

#### 3. 1. 2. 1. 3      MOL System Segment Flow Schematic

A representation of the MOL System Segment hardware flow between the principal Associates and the MOL Launch Site (MLS) is shown in Fig. 3-4. Factories and other facilities are shown in enclosed dashed-line blocks. The movement of a hardware item (AVE, AGE, AAE) is shown by a dash-dot-dash line. The DAC area for integration and test is shown as a separate facility only for clarity. Over-all grouped facilities (e. g., the SCF or MLS) are enclosed by heavy solid lines. Light solid lines on the schematic indicate a hard-line connection (cable or microwave link) between points.

#### 3. 1. 2. 1. 4      Top Level Function Flow Descriptions

The functions included within each block of the Flow Diagram (Fig. 3-2) and their starting and stopping points are defined below.

##### 3. 1. 2. 1. 4. 1      Block 1. "Evaluate MOL System"

The functional objective of this effort is to achieve a qualitative appraisal of the performance of the various elements comprising the MOL System and of the System as a whole. This appraisal shall facilitate: (a) management cognizance of important milestones both during and following each flight which will enable decisions to be made on a timely basis in regard to changes of in-flight programming and to future flights, (b) detection of deficiencies so that required corrective actions may be implemented, (c) determination of additions or changes which could improve future capabilities for manned or unmanned operations of military significance.

Each of the Associates will determine the data items he requires for this appraisal effort as a part of his participation in the analysis of

requirements for the assigned functions derived from the Top Level Flow Diagram (Fig. 3-2). These will include: the types and quantity of required data items to be recorded, transmitted by telemetry, retrieved, measured prior to launch or after recovery; evaluation criteria; and the equipment, personnel, and facility requirements for processing and reducing the data. Tradeoff studies shall be made as necessary to ascertain the data requirements. The Laboratory Vehicle Contractor will collate and intermediately integrate these requirements. He will also review the over-all system requirements to see that the data necessary for evaluation can indeed be obtained from all parts of the program.

An appraisal of the performance of the MOL System will be made after each flight and will include all of the required data items enumerated in this analysis, including such possible items as: test, transport, maintenance, training, simulation, installation, checkout, control, transfer, on-orbit operations, de-orbit, recovery, and post-recovery analysis.

3.1.2.1.4.2 Block 8. "Test, Accept, and Deliver MOL System"

The functions to be analyzed for requirements start with the completion of fabrication of the MOL AVE and supporting ground equipment, and proceed through evaluation tests, acceptance tests, qualification tests, shipment to the test range (or other location, in the instance of certain AGE), receipt and inspection at the MOL Launch Site (MLS) and checkout of ground equipment at the contractor receiving and maintenance area. The functions of this block terminate with delivery to the ILC for assembly and integration.

Each Associate responsible for contributing equipment or software to the MOL program will analyze his own area of responsibility to define his equipment, test, personnel, and facility requirements. The Laboratory Vehicle Contractor will collate and perform intermediate

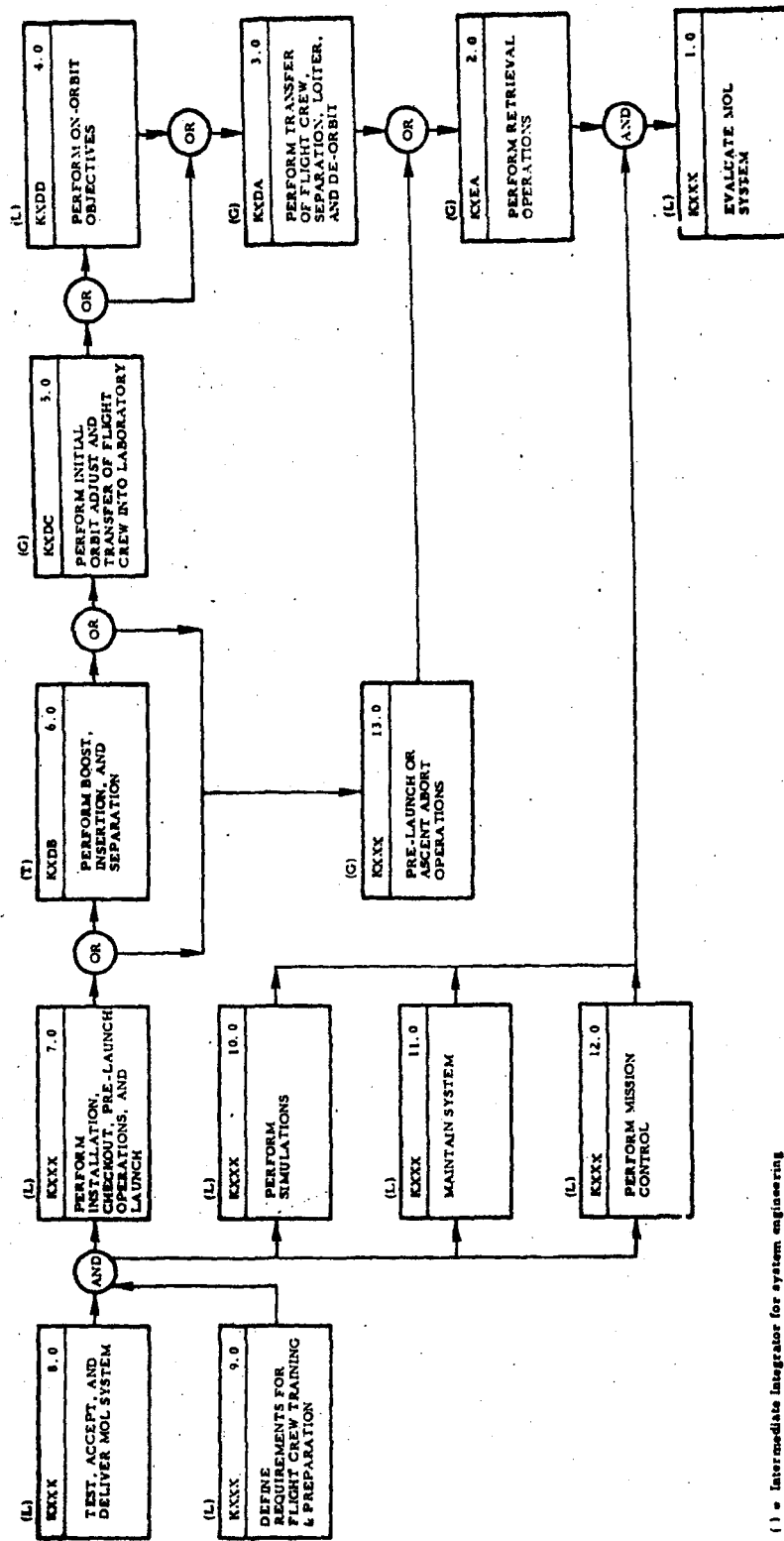

( ) - Intermediate Integrator for system engineering  
data of functions contained in block  
(L) - Laboratory Vehicle Contractor  
(T) - Launch Vehicle Contractor  
(G) - Canibal B Contractor

Figure 3-2. MOL System Top Level Functional Flow Diagram

FIRST DESIGNATOR MISSION CODE	SECOND DESIGNATOR ASSOCIATE CODE	THIRD DESIGNATOR AREA CODE
K MOL	10. Laboratory Vehicle Contractor	AA Contractor Factory Area
KA	(Douglas)	AB Douglas
KB	11. Gemini B Contractor	ABC IBM
KC	(McDonnell)	AC McDonnell
KD	12. Mission Payloads	AD Martin
KE	13. Flight Crew Equipment	AE GE
KF	Agency (MOL SPO)	BA Government Agency Area
KG	14. Titan III Agency (T-III SPO)	BB MOL Launch Site (MLS)
	14.2 AC Electronics	BBA ILC
	14.3 Martin Company	BBT Launch Pad in ILC
	14.5 Aerojet-General	BBW Receiving Inspection and
	14.6 UTC	Maintenance Areas
	15. Deputy for Civil Engineering	BBX Ordnance Areas
	(SSD)	BBY Propellant Storage Area
	15.1 Stearns-Roger (ILC)	BC Satellite Control Facility
	15.2 Daniel, Mann, Johnson and	BCC Satellite Test Center
	Mendenhall	CA Transport
	16. Launch Operations Agency	CB Factory to Factory
	(65--ATW)	CC Factory to Government
	17. Flight Operations Agency	Area
	(SCF)	CD Govt Area to Govt Area
	18. Recovery Agency	DA In-Flight
	(DOD Manager)	DB Ascent
	19. Test Support Agency	DC Injection
	20. Overall Systems Integrator	DD On-Orbit (OV)
	(Douglas)	DE On-Orbit (Loiter)
X	Plurality of Contractors	DF Re-Entry
	and/or Agencies	DG Descent
(-)	Designation Pending	EA Recovery
		EB Planned Recovery Area
		EC Contingency Recovery
		Area
		ED Emergency Recovery
		Area (MLS)
		EE Emergency Recovery
		Area (Other)
		FA
		XX Plurality of Areas
		(-) Designation Pending

Figure 3-3. MOL System Flow Diagram Code



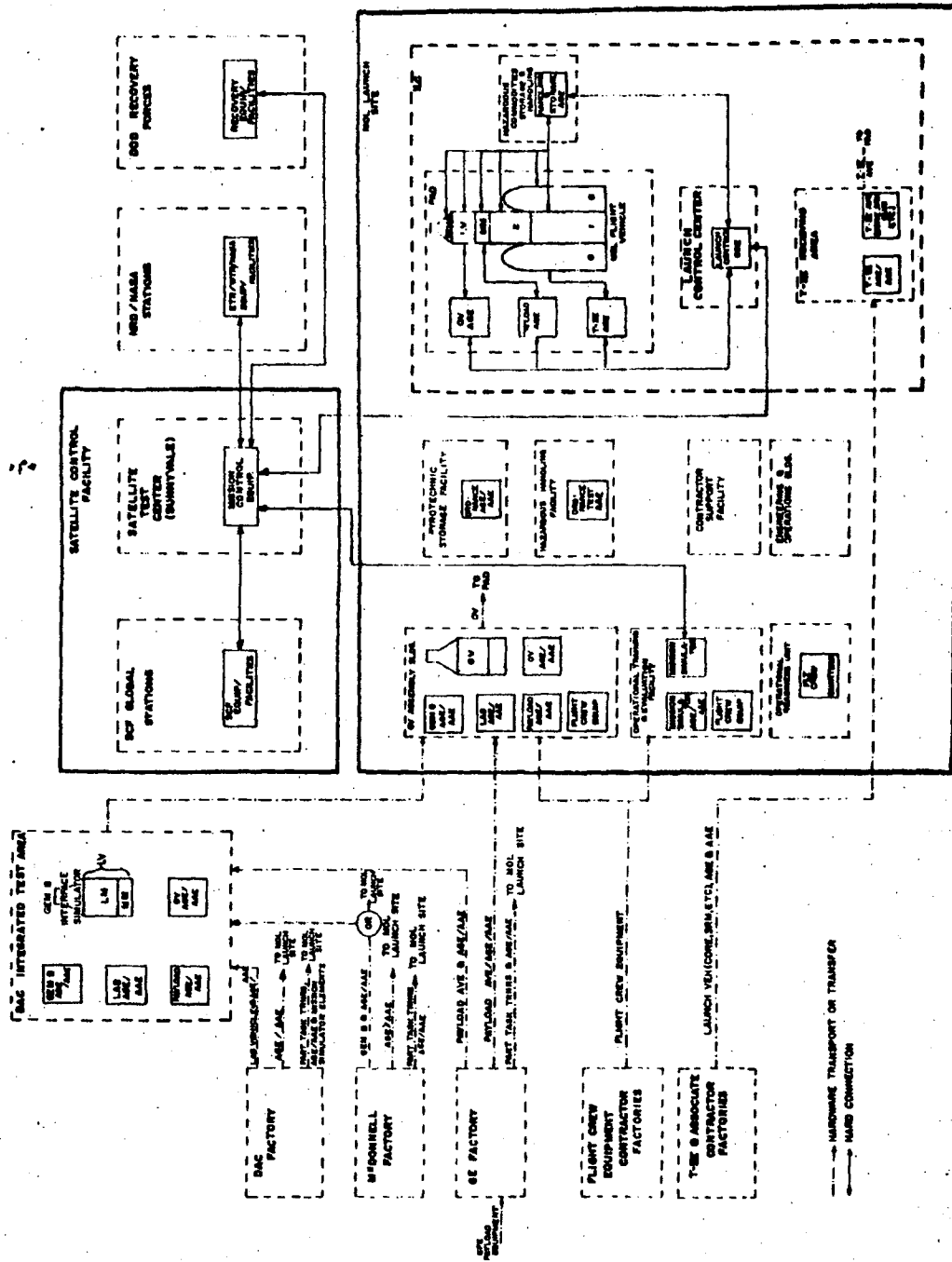

Figure 3-4. MOL System Segment Flow Schematic

integration of these requirements to ensure over-all system assembly test program, handling, and receiving compatibility. It is expected that the required intermediate integration will be minimal since, in the performance of these functions, the inter-contractor interfaces are limited.

3.1.2.1.4.3 Block 7. "Perform Installation, Checkout, Pre-Launch Operations, and Launch"

The Laboratory Vehicle Contractor will perform the intermediate integration of all of the requirements of these functions which start at the receipt of flight hardware at the ILC and terminate at lift-off. Also to be included in the requirements analysis are the installation and checkout of the ground systems equipment used at the ILC (excluding NRD and SCF equipment which are covered in Block 12), and accomplishment of a launch complex demonstration. As a result of this intermediate integration, the requirements for the launch operations are to be collated and integrated.

Branches of these functions covering the normal modes of operation are to be analyzed for requirements for such items as pad receipt, pad checkout, positioning for assembly and readiness operations, inter-Associate communications, and launch countdown. Also included shall be the installation and checkout operations at the pad, Launch Control Center, and propellant and hazardous-commodities storage areas. Branches of these functions covering refurbishment and non-normal modes of operation (such as equipment recycling after a hold or a scrub, or after an abort where damage is limited) shall be analyzed for requirements.

3.1.2.1.4.4 Block 6. "Perform Boost, Insertion, and Separation"

These functions start at lift-off and terminate when successful insertion into an initial orbit has been achieved and the Orbiting Vehicle has been separated from the final Launch Vehicle stage.

Boost, insertion, and separation under both normal and various contingency modes are to be branches of these functions analyzed for requirements for both personnel and equipment. The Launch Vehicle Contractor is responsible for the intermediate integration of all of the requirements of these functions. The Laboratory Vehicle contractor shall be responsible for the integration of requirements affecting the integrity of the OV.

3. 1. 2. 1. 4. 5      Block 5. "Perform Initial Orbit Adjust and Transfer of Flight Crew into Laboratory"

These functions start when a successful insertion and separation have been achieved and the flight crew can now prepare to perform the maneuver into another orbit and then to transfer from the Gemini B to the Laboratory Vehicle. Termination of these functions occurs when the second flight crew member completes his transfer, defined as the time at which he closes the tunnel door between the Laboratory Vehicle and the Gemini B.

Normal, contingency, and emergency modes of these functions are to be analyzed to determine the requirements for both equipment and personnel. The Gemini B Contractor will perform the intermediate integration of the requirements for these functions.

3. 1. 2. 1. 4. 6      Block 4. "Perform On-Orbit Objectives"

These functions start when the second flight crew member arrives in the Laboratory Vehicle following transfer and closes the tunnel door and terminate with the opening of the tunnel door for the departure of the first flight crew member.

Normal, contingency, and emergency modes of operation are to be branches of these functions. Laboratory Vehicle requirements, as well as payload requirements and procedures, and personnel requirements are to be detailed. The Mission Payload (Experiments Integration) Contractor will integrate the requirements for the payloads

and their operation, and will program the payloads by flight. The Laboratory Vehicle Contractor will perform the intermediate integration of all of the requirements for these functions.

3. 1. 2. 1. 4. 7      Block 3. "Perform Transfer of Flight Crew,  
Separate, Loiter, and De-Orbit"

These functions start when the first flight crew member opens the tunnel door preparatory to transferring from the Laboratory Vehicle to the Gemini B and terminate at earth touchdown. Both normal and emergency termination of the mission will be considered for flight crew departure from the Laboratory Vehicle. The Gemini B Contractor will perform the intermediate integration of the requirements for these functions.

3. 1. 2. 1. 4. 8      Block 2, "Perform Retrieval Operations"

These functions start with earth touchdown and include normal retrieval from planned recovery areas or from contingency recovery areas, as well as emergency retrieval operations. The function terminates with delivery of the flight crew and spacecraft to predetermined locations for initiation of post-flight analysis. The Gemini B Contractor will perform the intermediate integration of the requirements for these functions.

3. 1. 2. 1. 4. 9      Block 9. "Define Requirements for Flight Crew  
Training and Preparation"

The functional objective of this block is to ensure, for each flight, a crew that is adequately and specially trained and prepared to accomplish the particular mission. All affected Associates will have inputs for the flight crew training requirements. Examples of such inputs are: training for Gemini B functions, Laboratory Vehicle operation and maintenance, communications operations, mission operations and maintenance of special payloads, data handling, reprogramming of operations, housekeeping, emergency procedures, etc.

The Laboratory Vehicle Contractor as the intermediate Integrator will collate the separate requirements and integrate them into meaningful and compatible training requirements that, with optimum use of the simulators and trainers, will accomplish all of the objectives. Flight crew training will be accomplished by those Agencies assigned the actual training responsibility.

3.1.2.1.4.10 Block 10. "Perform Simulations"

Each Associate will analyze the simulation requirements of his equipment and determine the performance and design requirements for simulation equipment, personnel, and facilities. The Laboratory Vehicle Contractor will assemble the contributions of individual Associates as well as define the integrated requirements for the Mission Simulator.

3.1.2.1.4.11 Block 11. "Maintain System"

The functions covered here include all preventative and corrective (both scheduled and unscheduled) maintenance of AVE, AGE, AAE, and facilities. Included are ground maintenance before and during flight, and on-orbit maintenance of the Orbiting Vehicle. Requirements from each Contributing Contractor will be assembled by the Laboratory Vehicle Contractor acting as Intermediate Integrator.

3.1.2.1.4.12 Block 12. "Perform Mission Control"

This function is primarily centered in the time period starting with lift-off and terminating with recovery. However, certain closely related functional activities are also performed during the countdown, particularly during the period of the T-count.

Each Associate will develop his mission control needs as part of his participation in the analysis of the other appropriate functions on the Top Level Flow Diagram (e. g., "Perform Boost, Injection, and Separation", "Perform On-Orbit Objectives", etc.) and their appropriate sub-functions. Included are Mission Control requirements for

all of the networks and stations involved in the processes of monitoring, receiving and/or transmitting information bearing on the flight or on the readiness to commence or terminate flight. Included are the requirements for control, communications, weather and sea condition forecasts, tracking, telemetry, data recording and reduction, and status reporting. The Laboratory Vehicle Contractor is the Intermediate Integrator for the requirements of these functions.

3. 1. 2. 1. 4. 13 Block 13. "Pre-Launch or Ascent Abort"

The functions in this block include all abort modes which can occur prior to injection of the Orbiting Vehicle into a sustainable orbit. The abort can occur any time starting with entry of the flight crew into the Gemini B prior to launch and ending with injection of the Orbiting Vehicle into a stable orbit. The functions start with receipt of a signal in the spacecraft indicating an incipient failure and the need for emergency termination of the mission. These functions terminate upon earth touchdown. The Gemini B Contractor will perform the intermediate integration of the requirements of these functions.

3. 1. 2. 2                    System Segment List

The following MOL System Segments are identified. Necessary ground support equipment, simulators, software, and other segment-determined material and activities are included under the appropriate segment.

	<u>LOCATION IN THIS DOCUMENT</u>
Orbiting Vehicle System Segment	3. 3. 1
This constitutes all segments and parts of segments which are retained as a unit in orbit.	
Laboratory Vehicle System Segment	3. 3. 2
Gemini B System Segment	3. 3. 3
Mission Payload System Segment	3. 3. 4
Flight Crew Equipment System Segment	3. 3. 5
Titan III System Segment	3. 3. 6
Facilities System Segment	3. 3. 7
Launch Operations System Segment	3. 3. 8
Flight Operations and Support System Segment	3. 3. 9
Recovery System Segment	3. 3. 10
Test Support System Segment	3. 3. 11
Flight Crew System Segment	3. 3. 12

3. 1. 2. 3                    Contract End Item List

See paragraph 3. 3. X. 4 under each system segment.

**SPECIAL HANDLING**

~~**SECRET**~~

3.1.2.4

Dorian Functional Flow Diagram

Figures 3-5 and 3-6 illustrate the functional flow sequence for the major elements of the Manned automatic and automatic configurations, respectively, of the Dorian System (later).

**SPECIAL HANDLING**

~~**SECRET**~~



~~SECRET~~

SPECIAL HANDLING

3-5  
Figure 3-5

**MANNED AUTOMATIC DORIAN SYSTEM INTEGRATION FUNCTIONAL FLOW**

(later)

~~SECRET~~

SPECIAL HANDLING

3-28.2

~~SECRET~~

SPECIAL HANDLING

Figure 73-6

AUTOMATIC DORIAN SYSTEM INTEGRATION

FUNCTIONAL FLOW

(later)

~~SECRET~~

SPECIAL HANDLING

3-28.3

~~CONFIDENTIAL~~

- 3.1.3 System Effectiveness
- 3.1.3.1 Effectiveness Measures
- 3.1.3.1.1 General (C-4)

System Effectiveness is defined as the probability that the system will accomplish a specified mission within a given period of time under the planned support and usage conditions. The measure of MOL effectiveness shall be the extent to which the mission and the required data retrieval are accomplished.

In the MOL Program Safety, Reliability, Maintainability, Quality Assurance and Human Engineering shall be integrated in an Effectiveness program. This program shall be primarily directed to maximizing MOL program effectiveness consistent with the maximum cost effectiveness.

The scope of Orbiting Vehicle and payload on-orbit scheduled and unscheduled maintenance and repair shall be established as a result of design optimization. The MOL system shall be designed to permit on-orbit maintenance by the crew to the greatest extent consistent with the required ability to operate in the unmanned mode under remote control. Adequate accessibility shall be provided for maintainable items and provisions shall be made for storage of spare parts and tools.

The primary MOL Program objective, for purposes of this requirement, is defined as:

- (1) Completion of the total of the orbital man-hours activity for mission performance including such checkout, alignment, calibration, repair, preparation, execution, processing, examination, communications, and similar tasks which are an integral part of, or are in direct support of, the mission
- (2) Return to designated ground stations of the specified types, quantities, and qualities of data including that delivered by the astronauts in person
- (3) Provision of environmental conditions, life support, performance capabilities, and ground support for the duration of the missions as required to sustain the system and to perform the missions.
- (4) Determination of the capability of the Manned Orbiting Laboratory to operate effectively in an automatic mode and to establish a basis for the evaluation of performance, reliability, and operational limitations of unmanned operation relative to manned operation.

~~CONFIDENTIAL~~

~~SECRET~~

3.1.3.1.2 Effectiveness Apportionment (~~S-4~~)

The effectiveness of the MOL system segments shall be developed to the highest level consistent with maximum MOL program cost effectiveness. Assigned values are given in the following paragraphs; however, as a result of system analysis and optimization, it may become desirable to negotiate a different level to improve program cost effectiveness. Should such a situation arise, a request for adoption of a different level, together with the supporting analysis, shall be submitted to MOL SPO for review and approval. The mission, unless specified otherwise, extends from the initiation of the launch countdown to the final cessation of use of the element in question including data retrieval and, for the crew, recovery.

3.1.3.1.2.1 Orbiting Vehicle System Segment (~~S-4~~)

The allocation of effectiveness assigned to the Orbiting Vehicle Segment shall be for the time period from launch through 30 days of orbital operation to separation of the Gemini B. Since the Orbiting Vehicle segment combines portions of a number of other segments, values will be assigned under the other segments.

3.1.3.1.2.2 Laboratory Vehicle System Segment (~~S-4~~)

The combined effectiveness of the Laboratory Vehicle for the total mission shall not be less than 0.97 in the manned mode, and 0.90 in the automatic mode.

3.1.3.1.2.3 Gemini B System Segment (~~S-4~~)

The effectiveness of the Gemini B for its total mission shall be not less than 0.97. Gemini B shall be capable of on-orbit storage for 30 days, and re-activation shall not degrade the probability of successful re-entry below 0.9997.

3.1.3.1.2.4 Mission Payload System Segment (~~S-3 SAR~~)

The effectiveness of the Mission Payload Segment including the mission module structure for the total mission shall be not less than 0.95 for the manned version and \_\_\_\_\_ for the unmanned version.

3.1.3.1.2.5 Crew Equipment System Segment (~~S-4~~)

The effectiveness of the Crew Equipment, including backup modes, shall be not less than 0.999.

~~SECRET~~

~~CONFIDENTIAL~~

3.1.3.1.2.6 Titan III System Segment (S-4)

The effectiveness of Titan III from final countdown through insertion shall be not less than 0.90 for manned launches.

3.1.3.1.2.7 Launch Operations, Flight Operations, Recovery, and Test Support System Segments (S-4)

The composite effectiveness of these segments shall be at least 0.98 for manned operations and at least 0.80 for unmanned operations.

3.1.3.1.2.8 Flight Crew System Segment (S-4)

The mission effectiveness of the Flight Crew Segment shall be not less than 0.99.

3.1.3.2 Maintainability (U)

A maintainability program shall be implemented to run concurrently with equipment design, development, production, and system operation.

3.1.3.2.1 Maintenance Requirements.

3.1.3.2.1.1 Ground Maintenance Requirements (S-4)

The maintainability program for Launch Vehicle AGE shall conform to the requirements of MIL-M-26512C with the exceptions as specified in Attachment 1 to SSD Exhibit 62-126.

The requirements of MIL-M-26512C shall apply in the design and development of all OV AGE, unless specifically exempted. Maintenance at the launch site shall be restricted to major module/component removal and replacement. Module and component repair shall, in general, be accomplished at the point of manufacture. The items to be repaired at the launch site shall be restricted to that equipment which can be repaired and revalidated at the launch facility more economically than at the point of manufacture, and with no degradation of performance.

Ground maintenance of flight equipment shall be restricted to major module/component removal and replacement and/or to any module/component which is designed to be removed and replaced during on-orbit operation of the OV. Spare modules shall be stocked at the launch site as required.

The AGE shall be designed for ease of maintenance, and shall have features which will facilitate fault isolation and detection.

~~CONFIDENTIAL~~

~~CONFIDENTIAL~~

3.1.3.2.1.2 On-Orbit Maintenance Requirements (C-4)  
See Paragraph 3.1.3.1.1

3.1.3.3 Useful Life (U)

All equipment necessary for the MOL program shall have a minimum storage life to be specified by MOL SPO in the pre-launch and storage environment described in SSD Exhibit 65-7. The equipment shall have a minimum useful life to be specified by MOL SPO in the environment stated in SSD Exhibit 65-7.

3.1.3.4 Environment - Natural and Induced (U)

The environments applicable to the MOL Program are specified in SSD Exhibit 65-7 "Environmental Criteria for the MOL System."

~~CONFIDENTIAL~~

- (1) Prelaunch - (Applicable to all segments)
- (2) Launch/Ascent - (Applicable to Airborne Vehicle and ground environment)
- (3) On-Orbit - (Applicable to Orbiting Vehicle)
- (4) Descent and Recovery - (Applicable to Gemini B)

3.1.3.5 Transportability and Handling

3.1.3.5.1 General (U)

Existing transportation and handling equipment from governmental or commercial sources shall be used in preference to the design of new equipment. Equipment shall conform to the requirements of MIL-S-8512B and MIL-C-8090C.

3.1.3.5.2 Transportability (U)

Transportation planning for all components of the MOL System shall be by air in accordance with SSD Exhibit 63-3 and MIL-A-8421B. However, other modes of transportation may be utilized where more effective or when disassembly is required for air transport.

3.1.3.5.3 Handling (U)

The handling provisions for ground equipment shall be in accordance with the applicable requirements of MIL-S-8512B. To facilitate the handling of ground equipment, the design shall incorporate the safety provisions prescribed in AFSC Manual 80-5.

Instrumentation or other indicators shall be affixed to all transport assemblies, as required, to record or indicate any out-of-tolerance environments which have been encountered during transport or handling of sensitive assemblies or components.

3.1.3.6 Human Performance (U)

Documents governing system development for Human Performance fall into two categories: (1) those applicable or partially applicable for use as governing documents and (2) those usually concerned with operational system development, which may be used primarily for

guidance since they are not totally applicable. The documents concerned with human performance (Flight Crew and/or Ground Crew) are listed in Section 2.0 with these prefixes:

Applicable or partially applicable	Prefix HP
Guidance	Prefix GP

3.1.3.7 Safety

3.1.3.7.1 General (U)

The general safety engineering requirements specified under this paragraph shall include design efforts to preclude the inadvertent destruction of the system or injury to the crew and operating personnel. The requirement includes all possible hazardous interactions of facilities, equipment, procedures, and personnel, either singularly or in combination. The possible sources of system destruction or degradation which shall be covered by the requirement shall include but not be limited to:

- (1) High pressure
- (2) Explosion
- (3) Combustion
- (4) Acceleration
- (5) Corrosion
- (6) Electrical Effects
- (7) Radiation
- (8) Vibration
- (9) Stress
- (10) Fatigue
- (11) Noise
- (12) Toxicants

3.1.3.7.2 Ground Safety (U)

Applicable documents for Ground Safety are listed in Section 2.0 with the prefix letters SF.



System design for safety shall be coordinated with maintainability design to optimize system maintainability characteristics, safety characteristics, and human factors characteristics consistent with the effectiveness analyses and optimization.

In the event of conflict with the requirements resulting from the optimization of crew safety, crew safety requirements shall take precedence.

3.1.3.7.3 Crew Safety (U)

The flight equipment design and development process shall include the analysis, specification control, and review of parts, materials, and designs (including human engineering provisions) to assure the maximum protection for the crew consistent with cost effectiveness.

The equipment design, where practicable, shall be such that no single failure shall be cause for a crew casualty or shall necessitate a mission abort.

3.1.3.8 Dangerous Materials and Components (U)

- (1) Concentrations of toxic compounds shall be within acceptable limits both for short term and for continuous exposure.
- (2) Techniques and equipments shall be selected to assure that safe exposure levels are not exceeded.
- (3) Dangerous materials and components will be prepared for delivery in accordance with Section 5 hereof, with special reference to paragraph 3f of SSD Exhibit 62-181.

3.1.3.9 Noise and Vibration (U)

(See SSD Exhibit 65-7 for Environmental Criteria.)

3.1.3.10 Life Support (U)

(See Paragraph 3.3.12)

3.2

SYSTEM DESIGN AND CONSTRUCTION STANDARDS

The System Design and Construction Standards contained herein shall be applicable to the performance, design, development, and test of the system equipment, as well as to the design disciplines, such as mechanical and electrical. Design requirements of this type shall be imposed by specifying the incorporation of the established military standards and specifications as applicable in the individual contract end item (CEI) specifications. The documents listed in Section 2 with the prefix DG shall be used as general guides in the design and construction of the MOL Program equipment.

3.2.1

General Design and Construction Requirements

Requirements specified herein shall apply to the design and construction of all system equipment. Those documents listed in Section 2 with the prefix letters DR form a part of this requirement.

3.2.1.1

Selection of Specifications and Standards

The selection of specifications and standards for the identification, control, and procurement of the commodities required to design and fabricate the equipment under contract shall be in accordance with MIL-STD-143A and the requirements of this specification. Only those military documents listed in ANA Bulletin 400T and/or DOD Index of Specifications and Standards shall be interpreted as being Group I documents as defined in MIL-STD-143A. Specifications and Standards of Governmental Agencies other than DOD (e. g., NASA, FAA, etc.) shall be interpreted as being Group III documents as defined in MIL-STD-143A.

Any Group III documents selected for use shall automatically necessitate the preparation of a specification control drawing and shall be so drafted to establish the specific document being referenced, its date of issue, and contractor control responsibility for its use.

Military Standards shall be employed to the maximum extent.

All standards or specifications, other than those established and approved for use by the Air Force, must be approved by the procuring agency prior to incorporation into the system specification.

3.2.1.2 Materials, Parts, and Processes

Materials, parts, and processes selected for this system shall be selected with attention given to the stringent requirements of temperature, temperature gradients, thermal conductivity, toxic contamination potential in crew atmospheric environments, vibration, shock, loads, pressure, lightweight construction, and simplicity of manufacture. To ensure compliance with optimum utilization of procedures, processes, methods, etc., the following shall be adhered to:

- (a) Attention shall be directed to prevent unnecessary use of strategic and/or critical materials. A strategic and critical materials list can be obtained from the procuring agency.
- (b) The use of non-standard materials, parts, and processes shall be justified as to the reason for their use in lieu of standard items as well as substantiation of their suitability for the intended application by submittal of engineering analyses, test reports, etc., to demonstrate that the replacement has satisfactory performance characteristics.
- (c) Those documents listed in Section 2 with the prefix letters MP apply to the Materials, Parts, and Processes requirements.

3.2.1.3 Standard and Commercial Parts

MIL-HDBK-300 shall be used to ensure the use of standard and commercial parts. Qualified parts shall be used. To comply with this requirement, the following definitions and procedures apply:

- (a) Military Specified Parts, Military Standard Parts, and MIL-Spec Parts are interpreted as those parts controlled by, and procurable under, the documents classed as Group I in MIL-STD-143A.

- (b) Government Standard Parts are defined as those parts controlled by and procurable under the documents classed as Group II and III in MIL-STD-143A.
- (c) Industry Standard Parts shall be understood to be those parts controlled by and procurable under the documents classed as Group IV in MIL-STD-143A.
- (d) Design Activity Standard Parts, Company Standard Parts, and Commercial Parts shall be understood to be those parts controlled by and procurable under the documents classed as Group V in MIL-STD-143A.
- (e) Full utilization shall be made of Inter-Service Data Exchange Program (IDEP). (U)

3. 2. 1. 4 Moisture and Fungus Resistance

Non-nutrient materials shall be used which will resist damage from moisture and fungus. Protective coatings will not be acceptable as moisture and fungus preventatives on parts which will lose the coatings during the normal course of inspection, maintenance, and periodic testing. "Moisture" shall be considered as containing salt from marine atmosphere (see MIL-STD-210). The tests necessary to satisfy this requirement are specified under MIL-STD-810A.

3. 2. 1. 5 Corrosion of Metal Parts

3. 2. 1. 5. 1 Electrolytic Corrosion of Metal Parts

The use of dissimilar metals and protection against electrolytic corrosion shall be controlled in accordance with MIL-E-5400G and MS 33586A. Care shall be taken to prevent equipment corrosion in the Laboratory due to moisture under zero g convitions. The moist salt atmosphere created by man's presence may increase such electrolytic problems.

3. 2. 1. 5. 2 Stress Corrosion

Materials, techniques, and processes shall be selected and employed with regard to heat treatment procedures, corrosion protection,

finish, and assembly and installation such that sustained/residual surface tensile stresses, stress concentrations and the hazard of stress corrosion, cracking, and hydrogen embrittlement are minimized.

3.2.1.5.3 Protective Methods

Protective methods and materials for cleaning, surface treatment, and application of finishes and protective coatings shall comply with MIL-F-007179B.

3.2.1.5.4 Materials Compatibility

Materials and surfaces which may be exposed to contact with effluents shall be selected for compatibility with these effluents insofar as design considerations permit. Suitable compatibility data are given in the Storable Propellants Handbook, AFBSD-TR-62-2.

3.2.1.6 Interchangeability and Replaceability

3.2.1.6.1 Interchangeability and Replaceability in Terms of In-Flight Maintenance Requirements

Insofar as possible, the design and manufacture of all MOL subsystem and experimental equipment shall not preclude the use of: common parts such as valves; electronic components such as transistors, capacitors, or printed circuit modules; or, equipment in which one unit or component can be utilized for several functions in many items of the same or different equipments. Connectors, fasteners, small tubing, and piping shall be designed such that satisfactory interchangeability can be accomplished for many of these common items to alleviate spare part requirements and variety of types of special tools required for interchangeable, or noninterchangeable but replaceable, parts of a common nature. Applicable documents are listed in Section 2 with the prefix letters IC.

3.2.1.7 Workmanship

The workmanship requirements of MIL-STD-454 shall be implemented with the aid of written standards for workmanship.

3.2.1.7.1 Quality Assurance

Quality assurance requirements must be implemented during the design and manufacturing phases to assure timely implementation of adequate and appropriate controls in accordance with MIL-Q-9858A and USAF Specification Bulletin No. 515. This will ensure that the materials, workmanship, and performance comply with specified standards, and that components have been manufactured and tested to approved drawings and specifications.

3.2.1.7.2 Inspection and Test Equipment Selection

The calibration system requirements shall comply with MIL-Q-9858A. (U)

3.2.1.7.3 Material Review Engineering and Quality Assurance

At the earliest practical point, the material review representatives shall be determined. The material review procedures shall comply with USAF Specification Bulletin No. 515.

3.2.1.7.4 Vendor and Subcontractor Selection and Control

The contractor shall have a plan and/or procedure for supplier selection and control. The system shall provide for continued assessment of suppliers. Provisions shall exist for requiring quality control systems in the plants of suppliers and lower tier subcontractors in accordance with MIL-Q-9858A. Specification control drawings shall comply with MIL-D-70327.

3.2.1.8 Electromagnetic Interference

The General Design and Construction Requirements for Electromagnetic Interference (EMI) shall comply with SSD Exhibit 64-4. Applicable specifications are listed in Section 2 with the prefix letters EI.

3.2.1.9 Identification and Marking

Equipment, assemblies, and parts shall be marked for identification in accordance with MIL-STD-130A. Specific identification requirements include such conditions as:

- (a) Equipment which may be damaged by operation in excess of the rated duty cycle shall be so marked.
- (b) Items with limited operating lifetime or shelf life shall be so marked, and a log shall be maintained and attached to the subject item.
- (c) Critical components, as defined by AFSCM 375-1, Exhibit VI, shall bear a high visibility and unique marker, plaque, or decal which will immediately identify these components. This identification shall not be used on any other type item, other than those classified as critical.
- (d) Applicable documents related to Specification and Marking are listed in Section 2 with the prefix letters IM.

3.2.1.10 Storage

The system shall be designed to minimize the degrading effects of storage environments. In the event that unwarranted system weight, bulk, environmental limitations, etc., are involved in achieving storage protection, special protective containers, covers, etc., may be used. Special design attention shall be devoted to critical items in accordance with AFSCM 375-1. System design criteria relative to the in-orbit storage of maintenance items needed during the orbital mission shall be established by design activities. These criteria shall be incorporated into CEI specification and critical component specifications. Applicable documents relating to Storage listed in Section 2 are preceded with the prefix letters ST.

3.2.2 Design Disciplines

The design criteria listed shall be limited to specific design disciplines and/or types of equipment.

3.2.2.1 Electrical

The electrical design discipline requirements have been prepared under SSD Exhibit 64-5. The applicable documents for this subject are listed in Section 2.0 with the prefix letters EE.

3.2.2.2 Mechanical

The general mechanical design discipline requirements specified in AFM 88-2 shall be applied to AVE, MGE, and OGE.

3.2.2.3 Hydraulic and Pneumatic

Applicable Hydraulic and Pneumatic reference documents are listed in Section 2.0 with the prefix letters HY.

3.2.2.4 Civil

Applicable civil engineering reference documents are listed in Section 2.0 with the prefix letters CV.

3.2.2.5 Human Engineering

Applicable human engineering reference documents are listed in Section 2.0 with the prefix letters HP for directly applicable documents and the prefix letters GP for those considered as guidance.

3.2.2.6 Safety

Applicable safety reference documents are listed in Section 2.0 with the prefix letters SF.

3.2.2.7 Maintenance Support and Spares Provisioning

Applicable maintenance support and spares provisioning reference documents are listed in Section 2.0 with the prefix letters MS or MP.

3.2.2.8 Environmental Criteria

Applicable environmental criteria reference documents are listed in Section 2.0 with the prefix letters EV.



~~SECRET~~ HANDLING

~~SECRET~~

3.2.3

Dorian Exceptions

The following additions/deletions comprise exceptions to the foregoing Design and Construction Standards as applicable to the Dorian Mission Payload.

a. Additions

(later)

b. Deletions

(later)

SPECIAL HANDLING

~~SECRET~~

~~SECRET~~

3.3 PERFORMANCE ALLOCATIONS

3.3.1 Orbiting Vehicle System Segment (U)

The Orbiting Vehicle shall be composed of the following system segments: the Gemini B, the Laboratory Vehicle, the Mission Payload, which includes the mission module structural shell, and the Flight Crew and Flight Crew Equipment.

3.3.1.1 Allocated Performance and Design Requirements

3.3.1.1.1 Mass Parameters

3.3.1.1.1.1 Weight Breakdown (S3 SAR)

Within the Orbiting Vehicle System Segment, the maximum design allocation of weights shall be as follows:

	<u>Manned- Automatic</u>	<u>Automatic</u>
Laboratory Vehicle Segment	11,425	
Gemini B Segment or Support Module	13,555 5,660 5,610	
Mission Payload Segment *	6,200 8,330	
Crew Equipment Segment	140 700	
Flight Crew Segment	360	
	26,425	

Weight allocations shall be in accordance with the requirements of MIL-M-38310.

3.3.1.1.1.2 Center of Mass

The OV center of mass shall remain within a cylinder whose centerline is coincident with the geometric centerline of the OV. The radius of the cylinder shall not exceed \_\_\_ inches at launch and \_\_\_ inches at any time during the flight.

3.3.1.1.1.3 Principal Axis Alignment

The angular deviation of the OV principal axis of inertia about the center of mass and the OV Body Axis (Reference 3.3.2.2.7.3) shall not exceed 1.0 degree.

3.3.1.1.2 Electrical Power

3.3.1.1.2.1 Orbiting Vehicle (C-4)

The Laboratory Vehicle central power system shall provide the total Orbiting Vehicle power requirement during launch and injection and while on orbit prior to Gemini B separation. The power demand over the entire 30 days is a nominal 2.0 kw with nominal peaks of 3.6 kw.

\* Includes Mission Module Structure

~~SECRET~~

~~CONFIDENTIAL~~

Peak power requirements which exceed the power supply capability shall be individually accommodated.

3.3.1.1.2.2 Gemini B (U)

Electrical power allocation to the Gemini B shall be a nominal 150 watts, ~~for normal on-orbit storage.~~ Nominal power levels of 480 watts for the launch and injection phase, 440 watts for the pre-orbital storage phase, and 570 watts for the pre-separation phase shall be provided from the Laboratory central power system.

The total abort and re-entry power system requirements shall be provided by the local Gemini B power supply.

3.3.1.1.2.3 Laboratory (~~C-4~~)

The Laboratory shall be allocated a nominal power of 1.35 kw for its functions during all phases of the mission after transfer to internal power.

3.3.1.1.2.4 Mission Payload (~~C-4~~)

A nominal      watts will be available for the combined Mission Payload Segment.

3.3.1.1.3 Leak Rate (~~C-4~~)

The over-all leak rate for the Orbiting Vehicle shall be based on the leak rate for the Gemini B and transfer tunnel (see paragraph 3.3.3.1.5), plus a leak rate of 1.5 lb/day for the degraded single gas mode (5 psia, 100 percent oxygen) for the Laboratory Vehicle. Leak rate for the normal dual gas mode for the Laboratory Vehicle shall be ratioed from the single gas mode value according to pertinent parameters of the atmospheric composition selected.

3.3.1.1.4 Effectiveness (~~C-4~~)

The Orbiting Vehicle System Segment combines a number of other segments, therefore values are assigned under the other segments. Crew safety probability for the 30-day orbital mission, including the time from insertion on-orbit to separation of the Gemini B, shall be at least 0.999.

~~CONFIDENTIAL~~

~~CONFIDENTIAL~~

3.3.1.2 Peculiar Performance and Design Requirements

The following requirements are common to all flight configurations.

3.3.1.2.1 Communication and Control

3.3.1.2.1.1 General (U)

The Communication and Control Systems located in the segments shall be capable of independent operation. Electromagnetic compatibility shall be demonstrated when systems located in the different segments are activated simultaneously.

3.3.1.2.1.2 Command System (U)

Isolation shall be provided between the Gemini B Command System and the Laboratory Command System to prevent inadvertent activation or interference with either Command System.

3.3.1.2.1.3 Data Transmission System (U)

Sufficient isolation shall be provided between the OV and Titan III and between the various portions of the OV to prevent interference between those systems when operating simultaneously.

3.3.1.2.2 Attitude Control Translation System (ACTS)

3.3.1.2.2.1 Operational Modes (U)

The on-orbit attitude control shall be provided by the Laboratory.

3.3.1.2.2.2 Orientation (U)

Capability to attain any attitude and the maintenance of this attitude in an inertial orientation shall be provided. Generation of disturbance torques by venting of stored material and by starting and stopping of rotating machinery shall be minimized.

3.3.1.2.2.3 Maneuverability (U)

Maneuvers shall be accomplished with the Laboratory ACTS.

~~CONFIDENTIAL~~

3-47

~~CONFIDENTIAL~~

3.3.1.2.3      Navigation (~~C-4~~)

Navigation data for the Orbiting Vehicle shall be derived by the SCF from ground tracking of the spacecraft. The SCF capability for orbit determination and orbit prediction shall be used to derive orbit parameters and/or time/position tables for execution of planned operations and/or data tagging.

3.3.1.2.4      Computation and Data Processing (~~C-4~~)

Computation capability shall be provided within the Orbiting Vehicle as required to support Mission Payload operations and the Laboratory Vehicle. Computer system hardware and software requirements shall be defined by the Laboratory Vehicle and Mission Payload Integration contractors. Compatibility with a ground software system is required.

3.3.1.2.5      Structural Design Requirements

3.3.1.2.5.1      General (U)

Sufficient strength and rigidity shall be provided to meet the maximum loading and/or environmental conditions within the envelope of mission requirements. The Laboratory Vehicle and the mission module shall be compatible in terms of load transmission capability and mating at the interface with the Gemini B, with the Titan III, and the Mission Payload.

3.3.1.2.5.2      Separation (U)

The capability shall be provided for separation on orbit between the Gemini B Segment and Laboratory System Segment, and between the Orbiting Vehicle and Titan III.

3.3.1.2.5.3      Thermostructural (U)

During normal orbital operations (including solar angle variations, within the limits of -60 deg and +60 deg), axial deformation of the mission module structure due to thermal gradients (measured with reference to a set of axes defined by the mission module/laboratory module mating plane and the mission module center line perpendicular to that plane), shall not exceed a maximum of (to be supplied).

~~CONFIDENTIAL~~

3.3.1.2.5.4 Aeroelasticity (U)

Flutter or other related dynamic instability shall be prevented on the Orbiting Vehicle system.

3.3.1.2.6 Flight Crew Transfer

3.3.1.2.6.1 Normal Mode (U)

The Gemini B crew transfer hatches will remain open and the Laboratory crew transfer hatch closed while both crew members are in the Laboratory. These hatches shall be operable while the crew are in pressurized suits.

3.3.1.2.6.2 Backup and Emergency Modes (U)

Provision shall be made for back-up extravehicular egress/ingress and transfer of flight crew members between the Gemini B and the Laboratory Vehicle. Extravehicular egress/ingress to Gemini B shall be via the regular Gemini B egress hatches and to the Laboratory through the extravehicular hatches. Extravehicular transfer capability shall be provided from all Laboratory Vehicle pressurized compartments to permit extravehicular transfer to Gemini B. The Gemini B egress hatches shall be closed after transfer of the last crewman to the Laboratory. Provisions shall be made for opening and closing the Gemini B and Laboratory egress hatches from either inside or outside while in a pressurized suit.

Emergency crew transfer from the Laboratory to the Gemini B shall include transfer through the internal tunnel in shirtsleeves (i. e., without wearing the MOL basic pressure suit) or in the MOL pressure suit assembly without umbilical attached.

3.3.1.2.6.3 Number of Transfers (U)

Laboratory expendable capability shall be provided sufficient to permit two return trips to the Gemini B during the mission in addition to the final transfer. Return to the Gemini B shall be upon completion of the mission or under emergency conditions and not as a planned activity.

~~CONFIDENTIAL~~

3.3.1.2.6.4 Ground Communications Coverage

Deleted.

3.3.1.2.7 Orbital Operations

3.3.1.2.7.1 On-Orbit Monitoring and Checkout (~~C-4~~)

Both ground telemetry data and in-flight monitoring panels shall be utilized for on-orbit monitoring and checkout. The parameters requiring checkout, the frequency of performing monitoring functions, and the locations of monitoring functions shall be specified for each Orbiting Vehicle subsystem. Orbiting Vehicle checkout shall be performed during the first few orbits and prior to activation or initiation of any new phase of the mission to establish performance parameters for each subsystem. Visual and/or audible signals shall be used to indicate existence of or impending malfunctions on selected items. Provisions shall be made for indication of subsystem or appropriate module level for malfunction detection.

3.3.1.2.7.2 On-Orbit Maintenance (~~C-4~~)

Design for maintainability shall be incorporated for those components or system elements where tradeoff studies show that flight crew safety, mission completion, and/or design adequacy will be best improved by the provision of a maintenance capability. Where design for ground maintainability (which includes accessibility and ease of removal and replacement of selected modules or components) does not degrade in-flight capabilities, it shall be incorporated into the design. Maintenance shall normally be limited to the interior of the Laboratory.

3.3.1.2.7.3 On-Orbit Extravehicular Capability (U)

The OV shall be provided with the capability to support extravehicular operations, consisting of Emergency Extravehicular Transfer (as defined in paragraph 3.3.1.2.6.2) and the requirement to umbilically support an inspection of any part of the OV exterior. Equipment to be utilized in such operation shall be as defined in paragraph 3.3.5.1.4. Duration of extravehicular operation shall be 2 hours nominal, 4 hours maximum.

~~CONFIDENTIAL~~

~~CONFIDENTIAL~~

3.3.1.2.7.4 Automatic Operation

Provisions shall be made in the orbiting vehicle to accomplish on-orbit operations in the automatic mode for up to 30 days. Automatic mode operation requires completely automated control of the vehicle, including malfunction detection and redundant component switching. On-board and/or on-ground support may be utilized for fault isolation and corrective action. In the manned version all automated subsystems shall provide for manual override or inhibit by the crew.

3.3.1.2.8 Aerospace Ground Equipment (AGE) (C-4)

The OV AGE shall include all the Gemini B, Laboratory Vehicle, and Mission Payload AGE necessary to transport, handle, mate, integrate, verify interfaces, calibrate, check out, isolate faults, monitor, record, service, and control the OV as an independent system and the OV as a system mated with the Titan III Launch Vehicle. Thus AGE shall provide means of (1) verifying the proper operation of the OV system during checkout, countdown, and launch, (2) determining whether the fully assembled system is operable within the prescribed limits of each segment, (3) assuring that all interfaces (electrical, mechanical, and human) between OV segments or with external surfaces are proper, and (4) identifying to the segment (or in critical systems, the subsegment) level areas of failure or operation outside of prescribed operating limits. The OV AGE shall be designed to support manned, unmanned, and the combined modes of operation.

The OV AGE shall be designed for compatibility with the Titan III AGE, and the ILC facilities. The OV AGE at the ILC shall provide capability for checkout and for launch with a minimum of facility down-time and duplication of equipment. The OV AGE to be utilized at the integrating contractor's facility shall be functionally identical to the AGE utilized at VAFB. The OV AGE shall be designed for ease of maintainability and interchangeability and shall have features which will facilitate fault isolation and detection. All OV AGE shall be acceptance tested prior to being utilized for OV AGE ground operations.

3.3.1.2.9 Mission Simulator(s) (U)

Mission simulators shall be provided to accomplish training in accordance with Paragraph 3.3.12.2.1.2.4.

~~CONFIDENTIAL~~



3.3.1.3            Functional Interfaces (U)

(Functional interfaces shall be listed here when defined by the cognizant Interface Control Working Group-ICWG.)

3.3.1.4            Contract End Items (U)

(The contractor shall provide for incorporation in this paragraph a list of the Contract End Items by CEI specification number, nomenclature, and the CEI into which it installs. This paragraph shall list all end items being provided under these system segments.)

SPECIAL HANDLING

~~SECRET~~

3.3.1.5 Mission Peculiar Requirements, Orbiting Vehicle

3.3.1.5.1 Orbiting Vehicle Vibration Limitations

During on-orbit mission payload operations, the amplitude of vibration at station 500 shall not exceed  $3.9 \times 10^{-5}$  inches (vector sum of the lateral components) from 5 cps to 150 cps due to any orbiting vehicle equipment that can not be shut down for at least 20 minutes.

3.3.1.5.2 Minimum Time Between Targets

The time in seconds between adjacent targets achievable by the system shall be no greater than  $\frac{\Delta\theta}{12} + 3$  or  $\frac{\Delta\phi}{6} + 3$  seconds, whichever is larger, where  $\Delta\theta$  and  $\Delta\phi$  are the stereo and obliquity angle changes, respectively, in degrees commanded between targets.

Manned Version

The actual time between targets is increased over the above by the time required for the astronauts to null the tracking error and rate error. It shall be a design objective of the system to minimize the time required for the astronauts to acquire targets and reduce the rate error to acceptable levels.

3.3.1.5.3 Photographic Data Return

3.3.1.5.3.1 Data Re-entry Vehicles (DRV's)

Sequentially following completion of one of the assigned blocks of photographic payload operations sufficient for one DRV, the specific DRV will be ejected from the Orbiting Vehicle and deboosted from orbit into the designated recovery area using its own deboost propulsion capability. Retrieval of the DRV will be by air recovery as the primary method, with water recovery as backup.

SPECIAL HANDLING

~~SECRET~~

~~SECRET~~ SPECIAL HANDLING

Manned - Automatic Configuration

Depending upon the design selected, the DRV film will be loaded automatically, or as a package by the astronauts. The capability shall exist to return 60 lbs. record in one to three DRV's.

Automatic Configuration

At least four DRV's will be provided. Each DRV will have a capability of returning 60 lbs. of record. The DRV's will be supported in a Support Module replacing the Gemini B system segment.

3.3.1.5.3.2 Data Readout Subsystem (Manned - Flights Only)

A capability shall exist to process selected photographic frames and transmit all or selected parts of the scene from the original negative to the ground over a wideband data link. The length of time required to transmit the scene from a 5 square-inch segment of the negative shall not exceed five minutes. It shall be a design objective not to lose more than 20 percent of the resolution of the original negative in the processing, scanning transmission, and ground data recording process.

3.3.1.5.3.3 Data Return Via Gemini B (Manned Version Only)

The Gemini B System Segment will have the capability to return \_\_\_\_\_ of the photographic record obtainable on the 30-day mission.

3.3.1.5.4 Command and Control

Manned - Automatic Configuration

The command and control will be provided by an integrated system of astronaut, vehicle hardware, software, and ground support system. The capabilities of each contributor shall be used to maximize the number of targets photographed at high resolution.

~~SECRET~~ SPECIAL HANDLING

~~SECRET~~ SPECIAL HANDLING

Automatic Configuration

The Command and Control will be provided by an integrated system of vehicle hardware, software and ground support system. The capabilities of each contributor shall be used to maximize the number of targets photographed at high resolution.

3.3.1.5.4.1. Vehicle Hardware and Software Requirements

The major vehicle hardware and software requirements for command and control consist of:

- a. Target and Orbit Data Processing
- b. Provision of Astronaut Controls and Displays (Manned Flights only)
- c. Cueing System Control (Manned Flights only)
- d. Acquisition Scope Control (Manned Flights only)
- e. Tracking Mirror Control
- f. Camera Control
- g. Instrumentation Control
- h. Communications Control
- i. Data Readout Control (Manned Flights only)
- j. Target Photographic Quality Information Processing

Detailed requirements for the above command and control functions are given in Section 3.5.3.4.

3.3.1.5.5 Target Acquisition

The target acquisition system (exclusive of the astronaut) shall be capable, with 95 percent probability, of automatically acquiring the target and holding the aiming error to less than  $0.2^{\circ}$  throughout the range of  $\pm 30^{\circ}$  in track and  $\pm 40^{\circ}$  cross track. Further, the system shall be capable of correcting the aiming error to  $0.1^{\circ}$  within two seconds under control of an astronaut.

~~SECRET~~ SPECIAL HANDLING

3.3.1.5.6

Malfunction and Post-Gemini Separation Operations  
(Manned Flights only)

To permit obtaining maximum useful performance data on the Dorian System under flight conditions, the Orbiting Vehicle shall be designed so that operation of the Dorian System hardware shall be possible:

- a. Even if the astronauts cannot enter the Laboratory Vehicle for safety or other reasons.
- b. Following separation of the Gemini vehicle.

It is not intended that major design perturbations be required to implement this requirement, nor that all Dorian systems be operable. For example, the above shall not require that unmanned operational capability be provided for hardware for which only manual operation by the astronauts is feasible. Return of useful photographic data shall not be a requirement under conditions a. and b. above.

3.3.1.5.7

Mission Payload Ground Handling

The mission module temperature, humidity, and dust control requirements, together with the necessity to maintain precise alignments within the orbiting vehicle must be considered in designing the ground handling equipment for use at the launch base.

~~CONFIDENTIAL~~

3.3.2

Laboratory Vehicle System Segment (C-4)

The Laboratory Vehicle shall be approximately 10 feet in diameter and 20.5 feet long divided into two sections, one pressurized and one unpressurized. The pressurized section will consist of two compartments to enclose and support the operation of environmental control, life support, attitude control, power generation, communications, vehicle status monitoring, and mission equipments. The pressurized section shall provide housing for service items and a crew transfer tunnel.

3.3.2.1

Allocated Performance and Design Requirements

3.3.2.1.1

Volume

3.3.2.1.1.1

Pressurized (C-4)

The Laboratory Module shall provide a pressurized volume of approximately 1000 cu ft, divided between two compartments. The baseline design of the manned version of the Laboratory Module shall provide a minimum of 200 cu ft per man of free volume. The total free volume in the final design will be based upon the optimal design for man's effectiveness in the Laboratory Module.

3.3.2.1.1.2

Unpressurized (C-4)

The Laboratory Module shall provide a usable unpressurized volume of approximately 500 cu ft.

3.3.2.1.2

Internal Arrangement (C-4)

The equipment arrangement in the pressurized section shall provide for maximum free volume for crew mobility. Provisions for flight crew personal requirements shall be integrated into a specific area of the pressurized section and all manually-operated control functions shall be related for functional efficiency. Equipment shall be packaged for minimum flight crew interference and injury. The over-all internal arrangement shall provide for convenient and simple management of vehicle operational and maintenance tasks by the flight crew. Maintainability objectives shall be adhered to in defining internal arrangement and equipment packaging. Prior to launch, isolation of faulty equipment at the black box level shall not require disassembly of laboratory pressure bulkheads for removal and replacement. Equipment packaging shall be compatible with accomplishing the above corrective action through available hatches.

~~CONFIDENTIAL~~

~~CONFIDENTIAL~~

Location of the display and control subsystem consoles shall be compatible with the reach envelope and visual capabilities of the crew. Means shall be provided to stabilize the crew's position to permit activation of controls under zero-g, permitting a fixed frame of reference. The layout shall be arranged such that, where necessary, a pressure-suited operation may be accomplished.

The display and control subsystem shall provide necessary controls and displays to accomplish vehicle management functions, specific missions, and information management. The controls and displays shall be integrated to the extent possible and multipurpose displays provided where effective. This subsystem shall be capable of varying flight requirements with respect to mission accommodation.

3.3.2.1.2.1 Aft Pressurized Compartment (S-4)

The equipment in the aft pressurized compartment (launch orientation) shall be arranged circumferentially on the vehicle inner wall to accommodate a "head-up" crew position in pre-launch and launch attitude. The arrangement shall afford maximum free volume for crew mobility and shall provide mutually independent but functionally integrated areas for vehicle operations, mission operations, technology operations, information management, and food-exercise-hygiene center. The over-all internal arrangement shall provide for convenient and simple management of the vehicle by the flight crew.

3.3.2.1.2.2 Forward Pressurized Compartment (S-4)

The equipment in the forward pressurized compartment shall be installed in console areas arranged to permit maximum freedom of movement by the crew to and from Gemini B and the aft pressurized compartment. The compartment shall provide for extravehicular activity equipment, data re-entry vehicle storage, maintenance and repair functions, permit two crewmen to simultaneously don pressure suits, and accommodate sleeping and recreation facilities.

3.3.2.1.3 Flight Crew Stay Time (S-4)

The Laboratory Vehicle shall provide for a nominal on-orbit stay time for a two-man flight crew of at least 30 days, plus a 10 percent reserve.

~~CONFIDENTIAL~~

~~CONFIDENTIAL~~

3.3.2.1.4 Effectiveness (U)

Effectiveness requirements for the Laboratory Vehicle system segment are specified in paragraph 3.1.3.1.2.2.

3.3.2.2 Peculiar Performance and Design Requirements

3.3.2.2.1 On-Orbit Maintenance (Deleted)

3.3.2.2.2 On-Orbit Technical Data (~~S~~-4)

Technical data on each of the Orbiting Vehicle segments and their subsystems, as required by the flight crew in the performance of their operational functions, shall be provided in a convenient and easily accessible form and location.

3.3.2.2.3 Data Re-entry Vehicle (~~S~~-4)

The Laboratory shall be capable of incorporating the necessary equipment for recoverable data capsules aboard any designated flight. The capability shall permit: access for playing data into the capsules in an environmentally controlled atmosphere; means for adjusting and measuring any environmentally controlled atmosphere; means for adjusting and measuring any required ballast; means for deploying the DRV without adverse effects on the OV; and means for controlling the attitude and time of release.

3.3.2.2.4 Outgassing, and Impingement

The Laboratory shall be designed so that no effluents shall impinge deleteriously on the Orbiting Vehicle. Positive control will be exercised to minimize contaminant introduction into the Laboratory Vehicle atmosphere.

~~CONFIDENTIAL~~



~~CONFIDENTIAL~~

3.3.2.2.5

Communications and Data Processing Requirements

3.3.2.2.5.1.

Communications

3.3.2.2.5.1.1

General

Laboratory Communications shall be compatible with the Flight Operations and Support System Segment and shall make primary use of the USAF Space Ground Link Subsystem (SGLS). Secondary systems include UHF voice, 375 mc/s commanding, and a back-up telemeter. An S-band transmitter shall provide wideband data transmission. The Laboratory communications equipment shall be extendable directly, or by modular add-on, to at least the maximum performance limits of the SCF ground configuration specified herein.

3.3.2.2.5.1.2

Integrated Tracking, Telemetry, Command,  
and Voice (TTCV) Transponder

The Laboratory shall contain a transponder consisting of a receiver and transmitter which combines TTCV functions over single up and down radio links. Performance specification for the integrated functions are given in subsequent paragraphs of this section.

The receiving portion of the transponder shall be activated either by the on-board computer stored program or manually. The transmitter shall be capable of being energized by the command link, by use of a stored program, or by manual switching.

3.3.2.2.5.1.2.1

Tracking

The SGLS-compatible phase coherent transponder shall provide, when used with an SCF SGLS ground station, on-orbit vehicle metric tracking data having  $1\sigma$  accuracies as follows:

Range	50 ft
Range Rate	0.2 ft/sec
Angles, Az & El	2 milliradian

3.3.2.2.5.1.2.2

PCM Telemetry Transmission

The transponder shall be capable of transmitting separately or simultaneously, two digital data serial bit streams as provided by the PCM telemetry or data recorders. One digital data input shall have a data rate in the range of 4-128 kilobits/second and the other ranging from 4-1024 kilobits/second.

DOWNGRADED AT 3 YEAR INTERVALS;  
DECLASSIFIED AFTER 12 YEARS.  
DOD DIR 5200.10

~~CONFIDENTIAL~~

This document contains information that is the national defense of the United States within the meaning of the Espionage Laws, Title 18, United States Code, Sections 793 and 794, and the transmission or revelation of its contents in any manner to an unauthorized person is prohibited by law.

~~CONFIDENTIAL~~

3.3.2.2.5.1.2.3 Analog Telemetry

The SGLS compatible transmitter shall include, as a pre-flight option, a subcarrier which can accommodate IRIG FM/FM, PAM/FM, or other analog data having a double-sided modulation bandwidth of 500 kilocycles/second or less.

3.3.2.2.5.1.2.4 Voice

The TTCV transponder shall provide primary Laboratory-ground duplex voice link capability. The two-way channel shall accommodate nominal 3 kilocycle/bandwidth voice or 2400 kilobit/second digital voice at crew option.

3.3.2.2.5.1.3 375 Command Receiver

An SCF compatible 375 mc command receiver shall be provided as a back-up to SGLS 1 kilobit/second commanding.

3.3.2.2.5.1.4 Back-Up Telemetry Transmitter

A back-up PCM telemetry transmitter shall be provided to enhance ground PCM telemetry support availability. Compatibility with an existing or a firmly planned SCF receiving system is an important selection criteria.

3.3.2.2.5.1.5 Wideband Data Transmitter

A wideband data transmitter shall be provided capable of transmitting digital data at rates as high as 20 megabit/second. The transmitter shall operate in the 2200-2300 Mc RF band. Modulation, specific frequencies, frequency stability, and other technical characteristics shall be compatible with the SCF S-band wideband data link.

3.3.2.2.5.1.6 UHF Voice Transceiver

A Gemini-type simplex UHF voice Transceiver shall provide back-up to the SGLS voice link and shall provide contact capability with non-SGLS ground sites.

3.3.2.2.5.1.7 Voice Control and Intercommunications

A voice control center and remote control panels shall provide intercommunications functions and control for each set of voice receiving and transmitting equipment. It shall be possible for both crewmen to have simultaneous voice communications with the ground. Aural alarms of the monitor/alarm subsystem shall be broadcast via the intercom.

3.3.2.2.5.1.8 Vocoder

A vocoder shall provide voice transmission and reception via the TTCV transponder at the digital data rate of 2400 bits/second. The vocoder shall be compatible with the SCF vocoder type KY-585.

~~CONFIDENTIAL~~

~~CONFIDENTIAL~~

3.3.2.2.5.1.9 Communication Security

Communication security shall be provided as an in-flight option for voice, PCM telemetry, commands and wideband data transmission. The security devices shall be GFE.

3.3.2.2.5.1.10 Antennas and RF

The antenna and RF subsystem shall consist of the TTCV transponder, wideband data (S-band), UHF voice and command, and secondary PCM telemetry antennas (as required) and their associated transmission lines, power dividers, RF multiplexers, and RF switches for antenna selection and AGE use. The TTCV and UHF antenna system shall provide, at crew option, spherical or directive radiation coverage. The wideband data antenna shall provide earth coverage when the spacecraft is orbiting in its nominal attitude. The TTCV transponder antenna system shall be capable of use during launch.

3.3.2.2.5.2 Data Management

3.3.2.2.5.2.1 Command

The command subsystem accepts input signals in the SCF trinary format at a 1 kilobit/second transmission rate. Primary command validity checking and decoding functions and stored program functions shall be provided by the vehicle computer. A decoder shall provide real-time command back-up to the computer. Sizing of the decoder shall be based upon manned operation of the Orbiting Vehicle; less computer dependent experiment(s) for 30 days without the availability of a computer.

3.3.2.2.5.2.1.1 Decoder

The decoder shall perform validity checks and logic operations and generate command outputs to controller switching/relay circuitry. Indication of command message validity checks shall be provided as an output available for telemetering to the ground. The decoder design shall provide for expansion by modular add-on. Power to the command decoder shall be controlled by internal logic, by a vehicle stored program, or manually. No false command execution outputs shall result from over-or-under voltage, turn ON or OFF, or other transient power conditions.

3.3.2.2.5.2.1.2 Command Controller

The controller provides switching functions for various vehicle equipments. Solid state type switching of both latching and non-latching types shall be em-

~~CONFIDENTIAL~~

~~CONFIDENTIAL~~

played as required. The controller circuitry shall incorporate manual reset and over-ride features. Signal pick-offs shall be provided for channel actuation verification and/or status indication to be transmitted to the ground via the vehicle status telemetry. The controller shall accommodate a minimum of 256 channels and provide for expansion by modular add-on to 512 channels.

3.3.2.2.5.2.1.3 Teleprinter

The teleprinter shall provide hard-copy text of operational instructions, quantitative data for crew use, procedures and other similar comprehensive data transmitted via the command data link<sup>or</sup> vehicle/mission module computer,

3.3.2.2.5.2.2 Data Acquisition

3.3.2.2.5.2.2.1 PCM Telemetry

The PCM telemeter shall accept a variable mix of analog, digital and discrete data inputs, provide main data frame multiplexing, provide A-to-D conversion as required, generate appropriate timing signals for internal and external use, generate synchronization words, and combine data and sync into a serial, digital bit stream. These data shall then be provided as an input to the TTCV transmitter for real time data transmission or to a recorder for delayed data transmission. The real time data digital multiplexing shall be continuous during ascent and during station contacts on-orbit at a rate of 128 kilobit/sec or lower. The PCM telemetry shall accept primary mission module data from mission module submultiplexers. Telemetry timeline analyses shall provide for transmission availability of mission module data on each SCF station pass. Laboratory and mission module status and housekeeping data shall be multiplexed into a serial bit stream which shall be real-time transmitted each station pass (nominal) or recorded continuously or intermittently at crew option. Crew and other test data shall be intermittently multiplexed and recorded at rates up to 128 kb/sec for variable durations. Playback and telemetry dump of the recorded data shall use either the primary or secondary SGLS carrier at compatible transmission rates up to 1024 kilobit/sec.

The PCM telemetry system shall accommodate greater than 1000 vehicle status measurements for a given mission. Sampling rates shall extend from 1 sample per 10 seconds to at least 512 samples per second. High level (0-5 volts) and low-level (0-20 millivolts) remote multiplexers shall be used where appropriate from wiring, noise, and sampling considerations.

~~CONFIDENTIAL~~

3.3.2.2.5.2.2.2 Analog Telemetry

IRIG subcarrier oscillators, frequency multiplexers, etc., shall be provided as required to accommodate wideband instrumentation sensors such as vibration pick-ups required for Orbital Vehicle structure test.

3.3.2.2.5.2.2.3 Format Selection

The PCM main multiplexer design shall provide in-flight selection of any one of several pre-flight prepared digital telemetry formats and data rates.

3.3.2.2.5.2.2.4 Recorders

Magnetic tape recorders shall be provided as follows:

- (a) Voice - Intermittent analog voice recording with total capability in excess of four hours. Two playback speeds shall be provided: one at the 1:1 rate and the other at a fast rate consistent with transmission using the TTCV transponder, 500 kilocycle, analog telemetry channel. The recorder shall provide for both manual and voice recording control; shall record signals for the time correlation, and shall contain fast data search and retrieval features.
- (b) Telemetry Recorder(s) - Continuous or intermittent recording of vehicle status data for a total single-channel recording period of three hours minimum; provides storage of mission module data; records crew and other test data; stores keyboard encoded operational messages.

The nominal playback rate for stored telemetry is 128 kilobit/sec. Performance features to be considered shall include digital and analog record and reproduce, multiple recording channels, multiple tape speed, bi-directional record and reproduce, and provision for rapid search and retrieval.

All recorders shall allow in-flight tape change; magnetic heads and other critical components shall be capable of being removed, serviced, and reinstalled or replaced.

3.3.2.2.5.2.3 Timing

The timing subsystem shall provide time signal generation for data handling equipment, synchronization and control, time correlation of data, two channel event timing, time words for computer use, and time displays. Clock synchronization shall be manually selectable from either an internal signal source or externally. The internal clock shall have a time reference stability of  $10^{-7}$  per 30 days or better.

~~CONFIDENTIAL~~

This document contains information affecting the national defense of the United States within the meaning of the Espionage Laws, Title 18, United States Code, Sections 793 and 794, its transmission or revelation of its contents in any manner to an unauthorized person is prohibited by law.

~~CONFIDENTIAL~~

Initialization or up-date of the timing logic shall be accomplished via command (primary) or manually. Displays shall include Greenwich Mean Time (GMT), vehicle elapsed time (VET), vehicle ground time difference ( $\Delta T$ ), computer synchronization indication, two event elapsed time (EET) channels, and a mechanical clock.

3.3.2.2.5.2.4 Data Computation

3.3.2.2.5.2.4.1 Computer Hardware

The computer subsystem shall consist of two identical computers, together with the peripheral units described below, and shall be capable of performing all on-board computations and data-handling functions not implemented by other subsystems. It shall also provide the capability for performing command functions required to be initiated manually by the flight crew through the computer control units through the command link, or automatically through signals initiated by the monitor/alarm subsystem. The computer subsystem shall have the capability for executing all functions essential to Mission Module and Laboratory operation while utilizing only one of the computers and its associated peripheral units.

3.3.2.2.5.2.4.2 Computer Subsystem Control Unit

The computer subsystem control unit shall provide the capability for automatic control of the computer and data adapter units, either through the command link or upon a signal from the operating computer. The control unit shall provide for manual override or control when the OV is manned.

3.3.2.2.5.2.4.3 Data Adapter Units

The data adapter units shall provide all necessary signal conditioning, synchronizing, and buffering required between the computer and other orbiting vehicle subsystems. Separate adapter units shall be provided for interfacing the computers with the laboratory subsystems and with the manual and automatic equipment within the mission module. Redundancy shall be provided for the two types of data adapter units, and each unit shall be capable of interfacing with either computer.

3.3.2.2.5.2.4.4 Display and Control

The display and control unit provided with each computer subsystem shall provide all necessary capability for entering or requesting data from the computer, and

~~CONFIDENTIAL~~

This document contains information affecting the national defense of the United States within the meaning of the Espionage Laws, Title 18, United States Code, Sections 793 and 794, the transmission or revelation of its contents in any manner to an unauthorized person is prohibited by law.

~~CONFIDENTIAL~~

shall provide all necessary capability for flight crew control of the computer subsystem. The computer display panel shall consist of all indicators and lights necessary for non-textual communications between the computer and the flight crew.

3.3.2.2.5.2.4.5      External Storage

External storage shall be provided to allow read-only storage of all computer programs required during the mission. The storage unit shall be addressable by either computer for access to stored programs.

3.3.2.2.5.2.4.6      Software

Software provided for the vehicle-borne computer system shall be consistent with the need for optimizing storage and execution time requirements for those programs which are substantially unchanged from flight to flight, and with the need for facilitating changes in those programs which may change from flight to flight. Software languages shall be compatible with the types of functions for which they will be utilized, so that programming of vehicle-borne functions may be efficiently implemented.

3.3.2.2.5.3      Instrumentation and Display

3.3.2.2.5.3.1      Sensors

Instrumentation sensors and accompanying excitation sources, etc., shall be provided for all Laboratory subsystems as required for vehicle displays, telemetry, and the monitor/alarm.

3.3.2.2.5.3.2      Signal Conditioning

Conditioning of signals shall be provided for all Laboratory Vehicle subsystems as required for interface with PCM telemetry, vehicle displays, and the vehicle monitor and alarm subsystem. Provision shall be made for in-flight change of signal conditioner and remote multiplexer channels, adjustment of levels and calibration.

3.3.2.2.5.3.3      Displays and Controls

Provision shall be made for selection and operation of normal control and back-up modes as applicable for all vehicle subsystems. Displays shall include vehicle subsystem status and mode displays, those displays directly associated with subsystem control and operation, and certain critical parameter displays.

~~CONFIDENTIAL~~

~~CONFIDENTIAL~~

3.3.2.2.5.3.4 Monitor/Alarm

The vehicle monitor and alarm subsystem shall be capable of continuously monitoring or sampling approximately 150 critical vehicle subsystem parameters concerned with crew safety and with functions whose failure would jeopardize the mission. Points monitored shall be predicated on a maximum space-ground contact gap of 6 hours. Off-nominal performance which can persist for more than 6 hours shall be diagnosed on the ground. Sampling rates range from approximately one sample per second and one sample per 10 seconds, as required. Both aural and visual signalling shall be provided for out-of-tolerance conditions. Approximately 25% of the function/measurement tolerances and points monitored shall be programmable while in flight. Immediate or rapid crew action is required when certain (approx. 50) of the total points are out of tolerance. Manual override and reset features shall be incorporated. Design shall provide for modular expansion. Monitor/Alarm outputs shall be interconnected to the vehicle computer and directly to the controller(s) to provide automatic control of vehicle subsystems.

3.3.2.2.6 Environmental Control and Life Support

3.3.2.2.6.1 Scope (U)

The Environmental Control and Life Support (EC/LS) subsystem shall consist of the following functional areas:

- (a) Atmosphere Control
- (b) Thermal Control
- (c) Food Management
- (D) Water Management
- (e) Wast Management
- (f) Personal Hygiene

The specific requirements for each of the above functional areas are given below, together with the over-all requirements for the complete subsystem.

~~CONFIDENTIAL~~



~~CONFIDENTIAL~~

3.3.2.2.6.2 Atmosphere Control

3.3.2.2.6.2.1 General (U)

Atmosphere control for the Laboratory shall maintain and control the pressure, composition, and temperature of the atmosphere for the pressurized section. Provision shall be made for both shirtsleeve operation (normal activity) and pressure suit operation (special and emergency activity). Means shall be provided to support extra-vehicular activities, as defined in paragraph 3.3.5.1.4 and

3.3.1.2.7.3.

3.3.2.2.6.2.2 Atmosphere Pressure and Composition (C-4)

The atmosphere control provisions shall afford the inherent capability to operate in a normal dual-gas mode, with provisions for automatic degradation to a single-gas mode (5 psia - 100 percent oxygen).

Operation of the single-gas mode shall be assured by complete separability of the diluent gas supply and control from the dual-gas provisions. An independent oxygen partial pressure indicator shall be provided. The partial-pressures of the various atmospheric components shall be controlled to assure alveolar oxygen pressure between 60 and 175 mm Hg under all conditions. The normal operating level of alveolar oxygen pressure shall not be less than 100 mm Hg.

3.3.2.2.6.2.3 Pressure Control (U)

Provisions shall be made for both automatic and manual control of the atmospheric pressure and composition for either the single-gas or dual-gas operational modes.

3.3.2.2.6.2.3.1 Single-Gas Pressure Control (U)

A pressure regulation system shall control the total pressure for the single-gas mode. For pressure suit operation, devices shall be employed to automatically assure a level that provides for the specified normal alveolar oxygen pressure.

~~CONFIDENTIAL~~

~~CONFIDENTIAL~~

3.3.2.2.6.2.3.2 Dual-Gas Pressure Control (U)

An oxygen partial-pressure sensor shall be used to maintain atmospheric composition for the dual-gas mode. Redundant partial pressure oxygen sensors shall be provided. A pressure regulation system shall control the total pressure for the dual-gas mode and shall be designed to preclude flooding the pressure compartments with the diluent gas.

3.3.2.2.6.2.4 Shirtsleeve Environment (~~S-4~~)

An environment shall be provided that will result in physiological responses within ranges compatible with human comfort as defined for equivalent terrestrial conditions and levels of metabolic activity. Due consideration shall be accorded to the effects of reduced atmospheric pressure, different atmospheric composition, and elimination of natural convections. An optimum balance of atmospheric temperature, ventilation velocity, water vapor, partial-pressure, and mean radiant temperature shall be established and maintained. Relative humidity shall be maintained at less than 60 percent. Provisions for the control of shirtsleeve environment, based on nominal metabolic loadings (in the region of 400 to 800 BTU/hr) shall not require the utilization of active thermal cooling garments.

3.3.2.2.6.2.5 Atmosphere Storage Requirements (~~S-4~~)

Atmosphere storage shall be based on the following requirements:

- (1) Oxygen to provide for crew metabolic requirements during occupancy of the Laboratory pressurized compartments, and for Gemini B reactivation as specified in paragraph 3.3.1.2.6.3.
- (2) Oxygen to provide for the repressurization and leakage make-up for the Gemini B and transfer tunnel as specified in paragraph 3.3.3.1.5.
- (3) Oxygen and diluent to provide for leakage makeup of the Laboratory pressurized section

~~CONFIDENTIAL~~

~~CONFIDENTIAL~~

(including carbon dioxide desorption losses), one complete repressurization of the pressurized section, and a number of repressurizations as required of the pressurized compartment used for extravehicular egress.

- (4) Oxygen as required to provide for the support of extravehicular operations.

The above requirements do not include allowances that may be necessary for storage purge and leakage.

3.3.2.2.6.2.6 Oxygen and Diluent Storage (C-4)

The EC/LS oxygen requirements shall be integrated with the electrical power supply oxygen requirements. Diluent supply shall be provided from a supercritical cryogenic storage system. Design requirements for the diluent storage system (including standby time, orbital operation, extended mission capability, quantity measurement, and pressurization) shall be identical to those specified for the oxygen storage system in paragraphs 3.3.2.2.8.5.1 and

3.3.2.2.8.5.2.

3.3.2.2.6.2.7 Carbon Dioxide Control (C-4)

A regenerable adsorbent system shall be used for carbon dioxide control. The environmental control system shall maintain nominal carbon dioxide levels. The emergency carbon dioxide level shall not exceed 15 mm Hg for 4 hr.

3.3.2.2.6.2.8 Contaminant Control (C-4)

Equipment shall be provided for the control of odor and trace gases. Atmospheric debris traps shall be provided.

Concentration limits for contaminants shall be as specified in U. S. Navy Submarine Atmosphere Habitability Data Book, No. 250-649-1, Revision 1, Navy Bureau of Ships, corrected to the design atmosphere and duration.

~~CONFIDENTIAL~~

3-65

~~CONFIDENTIAL~~

Positive control shall be exercised to identify contaminants, their sources, and to minimize their introduction into the Laboratory atmosphere.

Rigid control of contamination and contamination producing materials and conditions shall be exercised in part by:

- a. Contractor contamination control specifications(s)
- b. Thorough contractor surveillance and approval of purchased ("make-or-buy) and laboratory installed contamination controlled components or parts.
- c. Installation of necessary diagnostic instrumentation and/or displays.

3.3.2.2.6.2.9 Pressure Maintenance (S-4)

Each compartment of the pressurized section shall be capable of maintaining normal pressure in the event of loss of pressure in the other compartment. The pressurization system shall be capable of maintaining a level that provides minimum acceptable alveolar oxygen pressure in either compartment for 5 minutes with a 1.0 in. diameter hole.

3.3.2.2.6.2.10 Repressurization (S-4)

Repressurization time for either pressurized compartment to a level that provides normal alveolar oxygen pressure shall be five min maximum. Diluent makeup to the normal dual gas mode shall be one hr maximum. Provisions shall be made for the rapid depressurization of the atmosphere in either pressurized compartment. Repressurization time for the Gemini B and transfer tunnel to the level specified in paragraph 3.3.3.1.5 shall be one minute maximum.

3.3.2.2.6.3 Thermal Control

3.3.2.2.6.3.1 General (U)

Thermal control for the Laboratory Vehicle shall provide for heat transport between the vehicle interior and the vehicle heat sinks. No critical equipment shall depend on the conditioned atmosphere for cooling.

The thermal control provisions shall be capable of removing the heat generated under the most unfavorable combination of crew operational mode and atmosphere operational mode. Capability shall be provided to accommodate the electrical loadings identified in paragraphs 3.3.1.1.2.1 and 3.3.2.2.11.

~~CONFIDENTIAL~~

~~CONFIDENTIAL~~

3.3.2.2.6.3.2 Space Radiator (~~C~~-4)

The space radiator shall form part of the external vehicle surface. Radiator tubing shall meet the meteoroid criteria specified in paragraph 3.3.2.2.9.2. The space radiator shall be designed and controlled to avoid freezing of the transport fluid under all operational conditions, including Laboratory Vehicle pre-activation. The space radiator shall properly perform for the orbital conditions defined in paragraphs 3.1.1.1.4.2 and 3.1.1.1.1.2. A single radiator failure shall not result in abort of the mission.

3.3.2.2.6.3.3 Expendable Matter (U)

The fuel cell excess water and the collected atmosphere condensate shall be utilized as expendable matter. This heat sink shall provide for supplementary and emergency cooling on-orbit, and for proper thermal control during the ascent environment. This technique shall be used only when the expulsion of such material is not deleterious to the OV. Disturbances of vehicle attitude due to the use of the water evaporator shall be minimized.

3.3.2.2.6.3.4 Vehicle Orientation (U)

The thermal control provisions shall be capable of maintaining required temperature limits, with the vehicle in any orientation, for approximately one hour.

3.3.2.2.6.3.5 Wall Temperature (U)

The temperature for the internal wall of the pressurized section shall not exceed 120 deg F, nor be less than atmosphere dew point, when subjected to the worst combination of vehicle orientation, crew operational mode, atmosphere operational mode, and equipment power loading.

3.3.2.2.6.4 Food Management (~~C~~-4)

Food management for the Laboratory Vehicle shall emphasize simplicity, palatability, and minimum interference with on-orbit duties. Food storage shall be at nominal cabin temperature (extremes not to

~~CONFIDENTIAL~~

3-67

~~CONFIDENTIAL~~

exceed 0-100° F) and shall be such as to protect the food supply from chemical and microbial spoilage. Surplus food residues and containers shall be collected and processed as part of the waste management provisions. Provisions for measuring and recording actual food intake shall be provided.

3.3.2.2.6.5 Water Management (C-4)

Water management shall provide for the efficient utilization of the water consumed and produced within the Laboratory Vehicle. The on-board source of potable water shall be the fuel cell electrical power supply. Potable water to meet crew metabolic requirements shall be stored in a separate water tank. The excess fuel water shall be stored in a waste water tank, in which shall also be stored the collected atmospheric condensate. The potable water shall be made available to the pressurized section at nominal temperatures of both 155 deg F and 55 deg F. Provisions for measuring and recording water intake and timing shall be provided.

3.3.2.2.6.6 Waste Management (U)

Waste management for the Laboratory Vehicle shall provide for the collection, transfer and storage of all crew and vehicle wastes. The crew waste collection devices shall be convenient and comfortable to use and shall require minimum maintenance to avoid unsanitary conditions. The vehicle atmosphere shall not be contaminated by the use of these devices and any airflow used in the waste collection process shall be decontaminated before return to the pressurized compartments. Containers impermeable to solids, liquids, gases and bacteria shall be provided for waste storage. Proper provisions shall be employed to ensure maintenance of putrefaction control of collected waste.

Provisions shall be made for the management and measurement on an individual crew member time line basis of daily urine volumes of 1800 ± 700 ml per man. This volume (less a 100 ml aliquot for subsequent

~~CONFIDENTIAL~~

lyophilization and return to earth for analysis) is to be delivered to and managed by the appropriate waste management equipment.

The daily fecal volumes per man of approximately  $100 \pm 100$  ml shall be collected for immediate lyophilization and stored for subsequent return to earth for analysis.

3.3.2.2.6.7 Personal Hygiene (U)

Personal hygiene for the Laboratory Vehicle shall provide for the convenient storage of all stores and devices used by the crew for skin cleansing, oral hygiene, shaving, and hair and nail cutting, as required. Proper provisions shall be employed to collect and process all debris and wastes produced as a result of these operations.

3.3.2.2.6.8 EC/LS Over-all System Requirements

3.3.2.2.6.8.1 Prelaunch Operation (U)

During the prelaunch phase, the system shall have checkout capability to verify required performance and operational parameters. Atmospheric conditioning of the pressurized volume shall be effected by purging and filling with the specified atmospheric composition at an excess of sea-level pressure. Ground cooling of the Laboratory shall provide for pre-launch requirements as defined in paragraphs 3.1.1.1.1 and 3.1.1.1.2.2.

3.3.2.2.6.8.2 Launch and Ascent Operations (U)

The atmosphere of the pressurized section shall be relieved during ascent to maintain a pressure differential compatible with the specified orbital requirement.

3.3.2.2.6.8.3 Safety Features (U)

All valves that connect the interior of the pressurized section to the space environment shall have manual closures and/or overrides. Filters shall be provided to protect critical components such as pumps and compressors. Relief shall be provided to prevent over-pressurization. Flow limiting devices shall be provided to prevent excessive use of gas supplies. Manual backup shall be provided to control repressurization.

~~SECRET~~

3.3.2.2.7 Attitude Control and Translation System (ACTS)

3.3.2.2.7.1 General (~~S-4~~)

The ACTS shall provide, without dependence upon the Laboratory vehicle computation capability (paragraph 3.3.2.2.5.23), the following functions:

- (1) automatic and manual attitude control
- (2) orbit maintenance
- (3) separation from boost vehicle
- (4) vernier insertion capability
- (5) orbit adjust
- (6) Laboratory Vehicle disposal

3.3.2.2.7.2 Functional Requirements (~~S-4~~)

The functional requirements of the following paragraph are those necessary to provide automatic and manual attitude hold and maneuver capabilities and translational acceleration to meet the MOL mission requirements. When ACTS is used to assure initial orbit the remainder of the ACTS propellant will be reprogrammed for degraded on-orbit operation.

3.3.2.2.7.2.1 Operating Modes (~~S-3 SAR~~)

- (a) Local Vertical and Orbit Plane Mode - the vehicle attitude shall be automatically maintained relative to the local vertical and the orbit plane.
- (b) Local Vertical/Relative Velocity Vector Mode - the vehicle attitude shall be automatically maintained relative to the local vertical and the relative velocity vector. The relative velocity vector is defined as the vector sum of the vehicle velocity vector and the velocity vector of the earth directly under the vehicle, both taken with respect to an earth-centered reference frame.
- (c) Inertial Attitude Hold Mode - shall provide for attitude hold relative to an inertial coordinate system and for sequential single axis maneuvers. Maneuvers may be commanded by the ground command or the crew.

~~SECRET~~



- ~~SECRET~~
- (d) Rate Stabilization Mode - shall provide for automatic damping of vehicle rates and for rate maneuvers controlled by ground command or manually. Rate maneuvers shall not exceed 5.0 deg/sec.
  - (e) Direct Control Mode - shall provide for manual high rates and manual emergency control. The reaction jets shall be controlled directly by the flight crew with a minimum amount of electronics to provide high reliability.
  - (f)  $\Delta V$  Mode - shall provide acceleration in the x direction. Capability shall be provided for ground or manual command of  $\Delta V$  set and initiate.
  - (g) Low Power Mode - electrical power consumption shall be minimized and the vehicle shall be oriented to reduce aerodynamic drag.
  - (h) Minimum Impulse Mode - shall be used by the flight crew to provide precise manual maneuvers.
  - (i) Vertical Acquisition Mode - shall provide automatic acquisition of the local vertical.
  - (j) Automatic  $\Delta V$  Termination Mode - shall provide automatic initiation and termination of velocity changes in the x direction.

3.3.2.2.7.2.2 Rate Roof Operation (~~S-3 SAR~~)

Provisions shall be incorporated into the system for automatically maintaining rates below the value specified in 3.3.2.2.7.4 when utilizing the Local Vertical and Orbit Plane mode, Local Vertical/Relative Velocity Vector mode, and the Attitude Hold mode.

3.3.2.2.7.2.3 Limit Cycle Deadband (~~S-3 SAR~~)

Two limit cycle deadbands shall be provided in each axis; one narrow deadband, and the other a wide deadband. The magnitude of the wide deadband shall be manually variable between 0.5 and 5.0 deg. The magnitude of the narrow deadband shall be selected to meet the requirements of item (2) of paragraph 3.3.2.2.7.4.

3.3.2.2.7.2.4 Inhibit (~~S-4~~)

The ACTS shall be capable of accepting an inhibit signal from other systems. This signal will inhibit all reaction jet firing until removed. A manual override shall be provided.

~~SECRET~~

3.3.2.2.7.2.5 Operating Life (~~C-4~~)

The ACTS shall be capable of continuous operation in any of the operating modes at any time during the mission. Propellant and thrust chamber requirements shall be based upon the operational mission profile.

3.3.2.2.7.2.6 Rate and Attitude Information

The ACTS shall be capable of providing body axis rate and attitude error signals to other OV subsystems. The probability of the error in analog rate signal exceeding 0.005 degree/second or the error in the analog attitude error signal exceeding 0.45 degrees shall be less than 0.997.

3.3.2.2.7.2.7 Attitude Acquisition

The ACTS shall be capable of automatic acquisition of and orientation to the local vertical and orbit plane when loss of acquisition is sensed automatically or upon ground command. Acquisition time shall not exceed 30 minutes.

3.3.2.2.7.3 Definition of Body Axes (U)

The body axes are defined as:

- (1) Pitch axis (y-axis) - This axis completes a right hand set with the roll and yaw axes.
- (2) Roll axis (x-axis) - An axis parallel to the vehicle longitudinal axis with the positive direction toward the Gemini B.
- (3) Yaw axis (z axis) - An axis normal to the vehicle longitudinal axis and parallel to a radius of the vehicle which is nominally earth-pointing. The positive direction is toward earth.

3.3.2.2.7.4 Accuracy Requirements (~~S-3 SAR~~)

The probability that the following angular deviations are not exceeded shall be greater than 0.997. (This is equivalent to a three sigma requirement for a normal statistical distribution).

- (1) Vehicle Attitude Reference - In the Local Vertical/Orbit Plane mode, the angular deviation of the pitch or roll reference signals from the local vertical shall not exceed  $\pm 0.35$  deg.

In the Local Vertical/Relative Velocity Vector mode the angular deviations of the pitch or

~~SECRET~~

~~SECRET~~

roll reference signals from the local vertical shall not exceed  $\pm 0.3$  deg and the angular deviations of the yaw reference signals from the relative velocity vector shall not exceed  $\pm 0.45$  deg.

In the Inertial Attitude Hold mode the drift of the attitude reference signal shall not exceed three deg per hour.

~~SECRET~~

~~SECRET~~

(2) Vehicle Body Axes -

Narrow Deadband - In the Local Vertical/Orbit Plane mode, the angular deviation of the pitch or roll body axes from the local vertical shall not exceed  $\pm 0.5$  deg. The angular deviation of the yaw body axis from the orbit plane shall not exceed  $\pm 0.5$  deg.

In the Local Vertical/Relative Velocity Vector mode the angular deviation of the pitch or roll body axis from the local vertical shall not exceed  $\pm 0.50$  deg. The angular deviation of the yaw body axis from the relative velocity vector shall not exceed  $\pm 0.60$  deg.

Wide Deadband - The deadbands shall be selected to minimize propellant requirements.

In the Low Power mode the angular deviation of the body axis from the desired reference shall not exceed  $\pm 4.0$  deg.

(3) Body Axis Rates - In the normal operating modes, rate control is not required. However, body rates shall be minimized to reduce propellant requirements.

During rate roof operation, control logic shall be provided to prevent the body axis rates exceeding  $\pm 0.005$  deg/sec for long periods of time.

3.3.2.2.7.5 Performance Requirements (~~S-3~~ SAR)

Translational Acceleration - The unidirectional translational acceleration shall be greater than  $0.40 \text{ ft/sec}^2$  in the x direction.

3.3.2.2.7.6 Gemini B Interfaces (~~S-4~~)

It shall be possible to control the ACTS from the Gemini B to separate the Orbiting Vehicle from the Launch Vehicle when initial orbit is achieved and for certain abort modes.

Capabilities in the Gemini B shall include:

- (a) ACTS electronics control monitors
- (b) ACTS propulsion control monitors
- (c) Controls for manual operation of the ACTS.

~~SECRET~~

3-73

~~CONFIDENTIAL~~

The Gemini B reference system and displays shall be utilized for visual reference but shall not be integrated with the ACTS electronics located in the Laboratory Vehicle.

3.3.2.2.7.7 Control Electronics Subsystem (~~C-4~~)

This subsystem consists of the reference element, the control logic and drive electronics, and the display element of the ACTS required to command the on-off reaction jet propulsion subsystem to control orbiting vehicle attitude and provide translational velocity changes while in orbit.

3.3.2.2.7.7.1 Reference Element (~~C-4~~)

This element shall contain the horizon sensors, gyros, and accelerometers necessary to provide vehicle linear acceleration, attitude, and angular rate sensing. It shall also include any other equipment necessary to provide outputs suitable for linear velocity, attitude, and angular rate control and display. Ion sensors shall be included in the selection of the Low Power mode reference element.

3.3.2.2.7.7.2 Display Element

Deleted.

3.3.2.2.7.8 Propulsion Subsystem (~~C-4~~)

The propulsion subsystem consists of thrust chamber assemblies (mounted to give vehicle rotation and translation) and propellant supply and pressurization assemblies. This subsystem responds to actuation commands from the control electronics subsystem. The subsystem shall be designed to permit full operation with only minor degradation in the event of a single malfunction of a component.

3.3.2.2.7.8.1 Subsystem Life (~~C-4~~)

The propellant supply and pressurization assemblies shall be capable of continuous operation during the on-orbit life of the Laboratory Vehicle. The thrusters shall be capable of operation in a worst-case duty

~~CONFIDENTIAL~~

~~SECRET~~

de 1

cycle imposed by the mission requirements. Time periods of acceptance testing, prelaunch testing (e. g., on-pad checkout and propellant handling) and all other durations of subsystem or component operation shall be considered when determining the life of the subsystem or any of its elements.

3.3.2.2.7.8.2 Propellant Gaging (~~C-4~~)

The subsystem shall include a method to measure and display to the flight crew the amount of propellant remaining in the subsystem.

3.3.2.2.7.8.3 Propellant Requirements (~~C-4~~)

The propellants shall be hypergolic bipropellants which are space-storable and shall be selected with consideration of thermal environment, minimization of ignition over-pressure transients, and the thrust chamber assembly selection.

The longitudinal translational velocity increment ( $\Delta V$ ) shall be          ft/sec for orbit maintenance, separation, vernier insertion correction, orbit adjust, and de-orbit. Additional propellant shall be provided for attitude control, propellant utilization, and contingencies.

3.3.2.2.8 Electrical Power Subsystem

3.3.2.2.8.1 General Requirements (U)

The Laboratory Vehicle Central Power System (CPS) shall be activated during prelaunch operations and shall provide the total Laboratory subsystem power during launch, insertion, orbit adjust, Laboratory activation, on-orbit and emergency mission phases.

3.3.2.2.8.1.1 Type of Power Source (U)

The generation of primary electrical power for the CPS shall be

~~SECRET~~

~~CONFIDENTIAL~~

accomplished with H<sub>2</sub>-O<sub>2</sub> fuel cell modules arranged in parallel, with automatic and manually actuated interconnections.

3.3.2.2.8.1.2 Nominal Power (~~C-4~~)

The CPS shall be a nominal 28v dc power system utilizing established design practices for subsystem compatibility.

3.3.2.2.8.1.3 Overloads (~~C-4~~)

During the 30-day on-orbit phase the CPS shall accommodate transients, intermittent and varying peak power levels and shall remain within its performance specification. Power requirements which exceed the specified capability of the CPS shall be supported separately.

3.3.2.2.8.2 Specific Requirements

3.3.2.2.8.2.1 Location (U)

The fuel cell powerplant shall be located in the forward unpressurized compartment of the Laboratory Vehicle.

3.3.2.2.8.2.2 Life (~~C-4~~)

The fuel cell powerplant shall have a minimum life of 1000 hr and during this life shall remain within its performance specifications while providing CPS power requirements.

3.3.2.2.8.2.3 Fuel Cell Redundancy (~~C-4~~)

The CPS shall have a minimum fuel cell module redundancy of 33 percent of the required modular configuration.

3.3.2.2.8.2.4 Parasitic Power (~~C-4~~)

Parasitic power generated and required by the fuel cell powerplant may be delivered to the main dc bus, but it shall not be included as part of the nominal 2.0 kw of power required to be delivered by the power plant for the CPS loads.

~~CONFIDENTIAL~~

~~CONFIDENTIAL~~

3.3.2.2.8.2.5 Emergency Power (~~C-4~~)

Emergency battery power shall be readily available and capable of maintaining emergency load conditions of 1 kw for a duration adequate to determine criticality of malfunction, Mission Control coordination, remedial action, and Flight Crew return to Gemini B.

3.3.2.2.8.2.6 Voltage (~~C-4~~)

During the mission phases, and for all combinations of loading within the mission power profile, including emergencies, the power sources shall maintain 25-31 volts at the bus.

3.3.2.2.8.2.7 Specific Reactant Consumption (~~C-4~~)

The total quantity of reactants including purge requirements needed by the fuel cell power plant to provide the required electrical power for the mission duration shall be no greater than 0.95 pounds per net kilowatt-hour.

3.3.2.2.8.2.8 Water Removal (U)

The water transport system shall remove the product water from the fuel cell. The water shall be delivered to the life support interface as potable for human consumption per paragraph 3.3.5.

3.3.2.2.8.2.9 Waste Heat (U)

The waste heat generated by the fuel cells shall be removed by a circulating coolant system. The coolant system shall dissipate its accumulated heat through an external space radiator located on the surface of the Laboratory. The coolant system shall allow the Laboratory Vehicle CPS to have an independent checkout and test capability.

3.3.2.2.8.2.10 Power Source Failure (U)

Power distribution from the fuel cell modules shall be designed so that the failure of any module or modules does not adversely affect

~~CONFIDENTIAL~~

3-77



~~CONFIDENTIAL~~

the operation of the remaining modules. Switch-out of the failed modules shall be automatically controlled with a remote manual override capability. Individual control of each module shall allow selective grouping of any combination of fuel cell modules.

3.3.2.2.8.2.11 In-Space Start (U)

The fuel cell power supply shall have the capability of an in-space shut down after on-orbit operation and an in-space start after on-orbit storage.

3.3.2.2.8.3 Power Control and Monitoring (U)

An automatic sensing and control system with a manual and remote command override capability shall be incorporated within the vehicle for monitoring and managing the CPS visual indications and status telemetry of electrical system events, conditions, outputs and malfunctions shall be provided. Manual and remote command control of load switching and reset of circuit breakers shall be provided.

The power control unit shall provide a distribution point for the major electrical power within the Laboratory, a switching capability, circuit access for ground maintenance, and fault isolation and protection.

3.3.2.2.8.4 Power Conditioning (U)

All Laboratory and Mission Payload equipment requiring power outside the characteristics of the fuel cell power plant shall provide individual power conditioning equipment.

3.3.2.2.8.5 Reactant Supply System (~~S-4~~)

The reactant supply shall be provided from a supercritical cryogenic storage system. A minimum of two tanks each shall be provided for hydrogen and oxygen storage. A redundant pressurization system shall be provided for each tank.

3.3.2.2.8.5.1 Capacity (~~S-4~~)

The cryogenic storage system shall have adequate capacity plus a 10 percent reserve to supply the EC/LS oxygen requirement and all of the

~~CONFIDENTIAL~~

~~CONFIDENTIAL~~

110

reactants for the fuel cell power system to accomplish the complete mission. The cryogenic storage system shall be capable of a minimum 48 hr non-vent standby time prior to launch. Design of the tankage system shall be such that venting will not occur during normal orbital operation. The cryogenic storage system shall not preclude provisions for an extended mission duration capability.

3.3.2.2.8.5.2 Quantity Measurements (U)

A quantity measuring system shall provide a continuous measurement of cryogenic quantity remaining. Accuracy of measurement shall be within 2 percent of the full scale indication.

3.3.2.2.8.6 Mission Phase Requirements (U)

During the pre-launch phase, the CPS shall have a check-out capability to permit performance parameters to be verified prior to launch. Performance parameters of the other Laboratory Vehicle sub-systems also shall be exercised, and the CPS shall sustain their launch mode power requirements, and those of the Gemini B upon transfer to internal power.

A capability shall be provided to monitor the CPS during all phases of a mission.

3.3.2.2.8.7 Laboratory Vehicle Equipment Power Requirements

3.3.2.2.8.7.1 Equipment Operating Voltage (~~C~~-4)

Laboratory equipment shall give specified performance when operated with 22-31 volts at the equipment power terminals.

3.3.2.2.8.7.2 Under and Over-Voltage (~~C~~-4)

Laboratory equipment shall withstand, without damage, continuous voltages from 20-33 volts at its power terminals and power interruptions up to one second and shall immediately give specified performance upon return to the equipment operating voltage.

~~CONFIDENTIAL~~

3-79

~~SECRET~~

3.3.2.2.8.7.3 Transients (S-4)

Laboratory equipment shall be capable of withstanding transients of  $\pm 100$  volts with respect to nominal bus voltage for durations up to 10 microseconds.

3.3.2.2.8.7.4 Electromagnetic Interference (U)

Electromagnetic Interference (EMI) control of the Laboratory Vehicle shall be as specified in SSD Exhibit 64-4.

3.3.2.2.8.7.5 Grounding (U)

The CPS primary power distribution shall incorporate a single point ground system and grounding network compatible with the Launch Vehicle, Gemini B, Laboratory Vehicle, and Mission Payload. Shield grounding shall be in accordance with SSD Exhibit 64-4.

3.3.2.2.8.7.6 Bonding (U)

The bonding requirements for the installation and interconnection of electrical and electronic equipment shall be as specified in SSD Exhibit 64-4 and MIL-B-5087B.

3.3.2.2.8.7.7 Electro-Explosive Device (EED) Installation (U)

The installation of EED pyrotechnic devices or actuators shall be in compliance with the requirements of SSD Exhibit 64-4 and AFWMTR-550-2.

3.3.2.2.9 Structural Subsystem (U)

3.3.2.2.9.1 Design Environment Criteria (U)

The environmental criteria applicable to the Laboratory Vehicle structure are as specified in SSD Exhibit 65-7.

3.3.2.2.9.2 Structural Design Criteria (U)

The structural design criteria applicable to the Laboratory Vehicle are specified in the "Structural Criteria for the Manned Orbiting Laboratory (MOL) Laboratory Vehicle System," Attachment No. 7 to Laboratory Vehicle Contractors Statement of Work.

~~SECRET~~

~~CONFIDENTIAL~~

3.3.2.2.9.3 Limit Load (C-4)

Limit load is the maximum anticipated load, or combination of loads, which a structure may be expected to experience during the performance of specified missions in specified environments.

The structure shall be designed to have sufficient strength to withstand simultaneously the limit loads, applied temperature, and other accompanying environmental phenomena for each design condition without experiencing excessive elastic or plastic deformation.

3.3.2.2.9.4 Factors of Safety (U)

	<u>Limit</u>	<u>Proof</u>	<u>Ultimate</u>	<u>Burst</u>
a. <u>Flight Loads</u>				
Manned Payloads	1.00	--	1.40	--
b. <u>Non-Flight Loads</u> (Other than Pressure)				
Dangerous to Personnel	1.00	--	1.50	--
Remote to Personnel	1.00	--	1.25	--
c. <u>Pressure Loads</u>				
Main Propellant Tanks	1.00	*	1.40	1.40
Rocket Motor Cases	1.00	*	1.25	1.40
Pneumatic Vessels (Including Accumulators and Pressurization Bottles)	1.00	1.67	2.22	2.22
Manned Cabins	1.00	1.33	2.00	2.00
Hydraulic Vessels (Including Accumulators and Pressurization Bottles)	1.00	2.00	4.00	4.00
Hydraulic Vessels (Normally Under Oil Pres- sure Only)	1.00	1.50	2.00	2.00
Hydraulic and Pneumatic (Lines, Fittings and Hoses)	1.00	2.00	4.00	4.00
Main Propellant (Supply and Vent Components)	1.00	1.50	1.88	1.88
Cryogenic Tanks	1.00	1.67	2.22	2.22

\* Proof pressure is defined as that pressure which is applied to a pressure vessel as a test at room temperature. (U)

~~CONFIDENTIAL~~

~~CONFIDENTIAL~~

3.3.2.2.9.5 Strength and Stiffness (C-4)

Structural failure shall not occur at loads less than ultimate.

The structure shall not experience deformations which impair functional performance at limit loads.

The structure shall not experience deformations which impair performance of function at loads less than limit.

Structural deformations shall not cause structural failure at loads less than ultimate.

Destructive flutter or other dynamic instability shall not occur at any condition within the design envelope.

Structural materials utilized in the pressurized areas shall possess demonstrated crack resistance under the specified environments and operations.

3.3.2.2.9.6 Hatches (C-4)

Pressure tight hatches, capable of actuation from either side, shall be provided at all ingress/egress hatches in the Laboratory pressurized compartments.

3.3.2.2.9.7 Windows (C-4)

Viewing windows, as appropriate, shall be provided in the Laboratory pressurized compartment to permit earth and star field viewing. Intra-Laboratory and transfer tunnel viewing shall be provided in the compartment bulkhead door.

3.3.2.2.10 Flight Crew Accommodations (U)

Provisions shall be made in the Laboratory for flight crew equipment, accessories, supplies, and test and monitoring as defined under Section 3.3.5.

~~CONFIDENTIAL~~

~~CONFIDENTIAL~~

3.3.2.2.10.1 Furnishings and Equipment (U)

The pressurized section shall provide furnishings and equipments in functional groups for maximum efficiency and flight crew safety.

3.3.2.2.10.2 Flight Crew Test and Monitoring Subsystem

3.3.2.2.10.2.1 Biomedical Test and Monitoring (U)

Equipment shall be provided to accomplish the biomedical tests as presented in 3.3.5.

3.3.2.2.10.2.2 Crew Performance Tests (U)

Equipment shall be provided to accomplish the crew performance tests as presented in 3.3.5.

3.3.2.2.10.3 Extravehicular Operations (U)

Extravehicular capability shall be provided to include restraint for the EV Crewman, umbilical Environmental Control System, visual monitoring equipment, effective illumination, and voice communications.

3.3.2.2.11 Mission Provisions (U)

Installation space shall be provided in the Laboratory Vehicle which is compatible with the mission equipment requirements. The space allocated shall permit installation of consoles, controls, displays, support brackets, signal and power conductors, and coolant lines to equipments, as required for a manned or unmanned operation.

3.3.2.2.11.1 Scientific and Technological Experiments (U)

A further objective of the Laboratory Vehicle design shall be to provide a configuration which will not preclude the incorporation of military scientific and technological experiments.

3.3.2.2.11.1.1 Space Provisions (U)

Any space not specifically required for primary purposes shall be evaluated for use by scientific and technological experiments. If feasible, any such space allocation should be consolidated to enhance its usefulness for experiments.

~~CONFIDENTIAL~~

3-83

~~CONFIDENTIAL~~

3.3.2.2.11.1.2 Support Provisions (U)

Consideration shall be given to the provision of support to scientific and technological experiments which may be installed in the above spaces. This shall include consideration of power, cooling, interconnections, and display and control consoles.

3.3.2.2.11.1.3 Mass Properties Provisions (U)

Requirements for local attachment of scientific and technological experiment equipment and the mass properties effects of such equipment upon the over-all segment loads shall be considered.

3.3.2.2.12 Flight Crew Training Equipment (U)

Training equipment, as appropriate, shall be provided to accomplish Flight Crew Training in accordance with 3.3.12. Portions of the Laboratory Vehicle procedures trainer shall be designed for integration into the MOL Mission Simulator.

3.3.2.2.13 Laboratory Peculiar AGE

3.3.2.2.13.1 Design (S-4)

The Laboratory Vehicle System Segment peculiar AGE shall consist of Operating Ground Equipment (OGE) and Maintenance Ground Equipment (MGE) designed to support all Laboratory segment assembly and checkout ground operations at the Laboratory contractors' facility. Portions of this AGE will be utilized for OV integration at the OV Integrating Contractor facility and at the launch site. Laboratory peculiar AGE shall be designed per requirements established in this specification, with maximum utilization of existing AGE. The Laboratory AGE utilized at the launch site shall be functionally identical to that AGE utilized at the contractor manufacturing facilities. The Laboratory peculiar AGE shall be designed for inclusion in GFE vans compatible with ILC operations. Laboratory peculiar AGE may be integrated into a complete OV checkout system as dictated by detailed design requirements. The Laboratory peculiar AGE shall be designed

~~CONFIDENTIAL~~

~~CONFIDENTIAL~~

for ease of maintainability, interchangeability, and shall have features which will facilitate isolation and detection. All Laboratory AGE shall be acceptance tested prior to being utilized for AVE ground operations. Data transmitted between Laboratory and its peculiar AGE shall be compatible with the data transmission system of the ILC at VAFB.

3.3.2.2.13.2 Performance (~~C~~-4)

The Laboratory Vehicle System Segment peculiar AGE shall include all the equipment necessary to transport, handle, store, verify, calibrate, checkout, monitor, record and service the Laboratory Vehicle. This AGE shall be capable of providing a means of verifying the proper operation of the Laboratory Vehicle and identifying areas of failure or operation outside the prescribed limits. This AGE shall be capable of integration with the complete MOL system AGE at VAFB. Fault isolation equipment at the launch site will be limited to that equipment necessary to isolate faults to the black box or replaceable component level. Detailed fault isolation and failure analysis within black boxes and/or components will be conducted at contractor/subcontractor plants. Portions of the Laboratory AGE shall support the Laboratory Vehicle System Segment end-to-end systems test when integrated into the OV checkout system.

3.3.2.3 Functional Interfaces (U)

(Functional interfaces shall be listed here when defined by the cognizant Interface Control Working Group - ICWG.)

3.3.2.4 Contract End Items (U)

(The contractor shall provide for incorporation in this paragraph a list of the Contract End Items by CEI specification number, nomenclature, and the CEI into which it installs. This paragraph shall list all end items being provided under these system segments.)

~~CONFIDENTIAL~~

3-85/6



~~SECRET~~ SPECIAL HANDLING

3.3.2.5 Mission Peculiar Requirements, Laboratory Vehicle

3.3.2.5.1 Space Allocation Requirements

3.3.2.5.1.1 Consoles and Camera Equipment

The Laboratory Vehicle shall provide for and accommodate consoles and camera equipment necessary for the operation, information display and processing activities for the mission payload. Console space requirements in the pressurized section of the laboratory module are as follows:

Manned Automatic Configuration

(later)

Automatic Configuration

(later)

3.3.2.5.1.2 Data Re-entry Vehicle Section (Manned Flights only)

The Data Re-entry Vehicle Section (DRVS) shall support, house, and protect up to three data re-entry vehicles (DRV), a launcher tank, auxiliary electrical and mechanical equipment required to control DRV separation and DRVS environmental control. The DRVS shall be located in the Laboratory Module which shall provide the following space and orientation:

(later)

3-76.1

3-86.1

~~SECRET~~

SPECIAL HANDLING

~~SECRET~~ SPECIAL HANDLING

3.3.2.5.2 Maneuvering Capability Requirements

The Attitude Control and Translation System shall have the capability to orient the orbiting vehicle to any roll, pitch or yaw attitude as commanded for photography of objects of secondary interest, for orbit adjust, crab correction, and other purposes. The specification for attitude accuracy shall remain the same for yaw offsets up to  $3^{\circ}$  from the orbit plane, otherwise the roll and pitch accuracy shall be allowed to degrade in proportion to the angle commanded by 1% of the commanded angle. The system shall be capable of settling within 30 seconds from the end of a maneuver down to within the specified photo period accuracies prior to an active photo pass.

Not more than one second can be allowed for control system settling to within the above attitude and attitude rate specifications following a disturbance during an active photographic pass.

3.3.2.5.3 Backup DRV Separation System (Automatic Configuration only)

A backup stabilization subsystem and backup command subsystem are required in order that a satisfactory orbit ejection attitude for at least one DRV separation may be obtained even though a failure has been experienced in any combination of primary electrical power, command and control, and attitude control subsystems.

3.3.2.5.4 Alignments  
(later)

3.3.2.5.5 Electrical Power  
(later)

3-86.2

SPECIAL HANDLING 3-86.2

~~SECRET~~

~~SECRET~~ SPECIAL HANDLING

3.3.2.5.6

Command and Control

~~SECRET~~ SPECIAL HANDLING 3-86.3

~~CONFIDENTIAL~~

3.3.3 Gemini B System Segment (U)

The Gemini B system segment shall consist of a re-entry module (REM), an adapter, and the supporting ground system. The Gemini B will be a NASA Gemini spacecraft with minimum modifications. The Gemini B shall be capable of performing 30-day earth orbital flights as an integral part of the OV and shall be capable of controlled earth orbit, loiter, re-entry, and water landing as an autonomous spacecraft. The Gemini B shall be dependent on other system segments for performance of certain functions; the extent of this dependence upon other segments shall be as specified herein and in the CEI specifications, design criteria, and interface specifications.

3.3.3.1 Allocated Performance and Design Requirements

3.3.3.1.1 Weights (U)

Maximum design launch weight for the Gemini B, including the REM and adapter, shall be 5610 lb.

3.3.3.1.2 Electrical Power (U)

Electrical power requirements for Gemini B are given in paragraphs 3.3.1.1.2.2 and 3.3.3.2.6.1.

3.3.3.1.3 Effectiveness (U)

The Gemini B system segment requirements for system effectiveness are given in paragraph 3.1.3.1.2.3.

3.3.3.1.4 Flight Crew Stay Time ~~(C-4)~~

The maximum total time the flight crew will be required to stay in the Gemini B is 62 hours. Of this time, at least 14 hours shall be available for loiter as defined in paragraph 3.1.1.6.

3.3.3.1.5 Leak Rate ~~(C-4)~~

The Gemini B REM leak rate, including the crew transfer tunnel, shall not exceed 2.5 lb/day. The REM leak rate with crew transfer hatches closed shall not exceed 1.5 lb/day. These leak rates

~~CONFIDENTIAL~~

3-87

~~CONFIDENTIAL~~

are for a pressurization of 5.0 psi under orbit environmental conditions. The leak rate at the orbital storage pressure of 0.1 psi minimum shall not exceed 0.05 lb/day.

3.3.3.2 Peculiar Performance and Design Requirements

3.3.3.2.1 Gemini B Requirements

3.3.3.2.1.1 Re-entry Module (~~C-4~~)

The Gemini B re-entry module shall consist of a modified NASA Gemini re-entry module capable of re-entry from polar orbits consistent with requirements of paragraph 3.1.1.1.3.3. This module shall provide protection for the flight crew from the environment of launch, space, re-entry, and landing within the limits specified herein. Provisions shall be included for mounting and protecting the equipment necessary for meeting the requirements of the subsequent paragraphs. Capability shall be provided for return of data within the Gemini B.

3.3.3.2.1.1.1 Crew Transfer (U)

Capability shall be provided to permit transfer of the crew members through the Gemini B main pressure bulkhead and heat shield to an internal tunnel consistent with the requirements of paragraph 3.3.3.2.11.

3.3.3.2.1.1.2 Data Package (~~C-4~~)

The Gemini B REM shall have the capability for return of data from orbit. The total weight and total volume available shall be a minimum of 170 lb and 3 cu ft, respectively.

3.3.3.2.1.2 Adapter(U)

The adapter shall consist of an approximately 56-in. long conical structure required to transition from the re-entry module to the Laboratory Vehicle. Provisions shall be included for mounting and protecting the equipment not required to be part of the re-entry module

~~CONFIDENTIAL~~

~~CONFIDENTIAL~~

but required to support the Gemini B. The Gemini B shall have the capability of separating from the Laboratory both the Laboratory/Gemini B adapter separation plane and the adapter retrograde separation plane. The Gemini B shall also have the capability of separating the re-entry module from the retrograde adapter section.

3.3.3.2.1.3 Strength and Rigidity (U)

The structure of the Gemini B shall be capable of sustaining all loads and environments imposed during the MOL mission for ground handling and transportation, pre-launch, launch, ascent, on-orbit, retrograde, re-entry, landing, retrieval, and abort modes.

3.3.3.2.1.4 Aerodynamic (~~C~~-4)

The re-entry module shall be trimmed by center-of-gravity position to provide nominal open-loop re-entry touchdown variations of not less than 80 n mi right and left total crossrange. The conditions for which this design goal shall be met are: mass distribution existing at the end of powered flight, re-entry from all orbits as defined in paragraph 3.1.1.1.4.2, nominal retro motor performance (six retrograde motors fired), and spacecraft minimum design weight. This capability shall be obtained only through the use of bank angle ( $\beta$ ) variations in the range of  $-90^\circ \leq \beta \leq +90^\circ$  where, for a zero value of  $\beta$ , the lift vector is directed away from the earth in the vertical plane.

3.3.3.2.2 Guidance and Control Requirements

3.3.3.2.2.1 General (U)

The Gemini B shall have a guidance and control system which provides the functions of back-up inertial guidance during the ascent phase and re-entry guidance and attitude control during the period in which the Gemini is separated from the Laboratory Vehicle.

~~CONFIDENTIAL~~

3-89

~~CONFIDENTIAL~~

3.3.3.2.2.2 Back-up Launch Guidance (U)

The Gemini B inertial guidance system, when in the back-up launch guidance mode, shall provide the required steering and discrete signals to the Titan III flight control system throughout the entire launch and ascent phases. Switchover to the Gemini B back-up guidance will be initiated by the Titan III MDS, or by the crew.

3.3.3.2.2.3 Re-Entry Guidance and Control (U)

The Gemini B guidance and control system shall provide these functions during retrofire and re-entry for both normal and aborted missions. Both automatic and manual re-entry control shall be provided. The guidance system shall provide an accuracy of  $\pm 4$  n mi (2 sigma dispersions) about the 70,000-ft altitude intersection point with the nominal re-entry trajectory if no error is present in the pre-retro initial conditions provided to the guidance system. The system shall have the capability to guide to non-nominal points.

3.3.3.2.2.4 On-Orbit Post-Separation Navigation and Control (U)

The Gemini B shall provide manual and automatic attitude control during this phase and, based on data transmitted from the ground directly or through the Laboratory Vehicle, shall provide a retrofire prediction navigation capability for up to 14 hr from receipt of data.

3.3.3.2.3 Instrumentation Requirements (U)

The Gemini B shall have the capability to sense, condition, and provide data appropriate to the particular flight phase. The instrumentation of the Gemini B shall provide capability to monitor critical Gemini B and Launch Vehicle events, critical Launch Vehicle parameters, Gemini B system status, and certain critical Laboratory status items by the flight crew and, as required, by the ground during all mission phases while the flight crew is in the Gemini B. Suitable instrumentation capability shall be provided to permit display and

~~CONFIDENTIAL~~

control of the Laboratory ACTS. Capability shall be provided for monitoring of Gemini B status by the ground and flight crew while the flight crew is in the Laboratory. The Gemini PCM digital telemetry format shall be used. Suitable interface modifications shall be provided for integrating and for establishing compatibility of SGLS with the Gemini PCM digital telemetry.

3.3.3.2.4 Environmental Control Requirements

3.3.3.2.4.1 General

The Gemini B shall provide the environmental control and life support (EC/LS) for the flight crew members until crew transfer. The Gemini B shall again provide environmental control and life support for the flight crew members after the Gemini B is reactivated for mission termination. The atmosphere of the Gemini B, while occupied, shall be 5-psi pure oxygen. The Laboratory Vehicle shall provide pressurization gas to maintain a minimum pressure of 0.1 psi in the Gemini B cabin and transfer tunnel during the on-orbit storage period. Breathing atmosphere, drinking water, and food shall be provided for the crew stay time in Gemini B compatible with the requirements of Paragraph 3.3.3.1.4.

3.3.3.2.4.2 Cabin Environmental Control

The capability shall be provided for complete environmental life support while the Gemini B is manned. The MOL pressure suit assembly shall be considered as an emergency back-up capability for this function. A potable water supply and a method for handling urine shall be provided. The cabin temperature shall be maintained within a range of 60°F to 95°F while occupied on-orbit; during re-entry the temperature shall not exceed 150°F.

3.3.3.2.4.3 Suit Environmental Control

Metabolic oxygen, pressurization, and ventilation shall be provided to support the MOL pressure suit assembly. The capability shall be



provided to allow the flight crew to perform the necessary operational functions in a closed loop suit with the cabin either pressurized or depressurized.

3.3.3.2.4.4 Equipment Environmental Control

Provisions shall be included for maintaining the Gemini B equipment within the required temperature range for both operating conditions and on-orbit dormant storage conditions.

3.3.3.2.4.5 Crew Transfer Environmental Control

The Gemini B ECS will supply suit ventilation, breathing oxygen, and emergency pressurization (if required) during transfer to the Laboratory. This same function shall be performed by the Laboratory ECS during transfer to the Gemini B. Capability shall be provided to permit extravehicular transfer between the Gemini B and the Laboratory as a back-up mode.

3.3.3.2.5 Propulsion Requirements

3.3.3.2.5.1 General

Sufficient propulsive capability shall be provided to permit attitude control of the Gemini B during normal re-entry, re-entry from aborts and on-orbit loiter, for separation of the Gemini B from the Laboratory Vehicle, and application of de-orbit velocity increment.

3.3.3.2.5.2 Re-Entry Control

The Gemini B re-entry control system (RCS) shall provide sufficient control authority over the entire re-entry flight to achieve the attitude control necessary to permit the full effectiveness of the re-entry guidance system and prevent any structural/temperature and crew load factor constraints from being violated through uncontrolled attitude disturbances.

3.3.3.2.5.3 On-Orbit Post-Separation Control

Propulsive capability shall be provided for control of the attitude and attitude rates of the Gemini B for on-orbit loiter after separation from the Laboratory Vehicle prior to de-orbit.

3.3.3.2.5.4 Launch Abort Separation

Abort modes using the Gemini B re-entry module shall be capable of using either the retrograde propulsion system or the on-orbit separation propulsion system to produce separation from a malfunctioning flight vehicle.

3.3.3.2.5.5 On-Orbit Separation

A propulsive capability shall be provided to separate the Gemini B from the Laboratory Vehicle on-orbit. The separation propulsion shall not impose detrimental effects on the Laboratory Vehicle. Sufficient separation distance shall be developed to preclude imposing detrimental effects on the Laboratory Vehicle by the operation of the retrograde motors.

3.3.3.2.5.6 Retrograde

The retrograde system shall provide an impulse sufficiently large to provide safe re-entry conditions from the nominal orbit and any intermediate orbit with one motor not operating. The retrograde impulse timing, orientation, and magnitude shall provide re-entry conditions which, considering all dispersions and re-entry bank angle command schedules, will not produce structural temperatures greater than the design values at any time during re-entry or at water impact.

3.3.3.2.6 Electrical Power Requirements

3.3.3.2.6.1 General

The Gemini B shall have the capability for providing power for ascent abort, on-orbit post separation, re-entry and retrieval. The Laboratory Vehicle shall supply Gemini B power as given in

paragraph 3.3.1.1.2.2. Provisions shall be made for utilization of ground power prior to launch and for all ground checkout.

3.3.3.2.6.2 Electrical Power Supply

Electrical power supply shall consist of a dc power source; ac power, as required by specific systems, shall be supplied by inverters and regulators considered a part of the utilizing system. There shall be redundancy in all power sources. Re-entry power sources must be active during the launch phase for abort purposes. Independent and redundant power sources shall be provided for pyrotechnic circuits.

3.3.3.2.6.3 Electrical Power Distribution

A capability for distributing the electrical power from the power supply to the using system shall be provided. The spacecraft structure shall not be used as an electrical current path. The system negative shall be grounded at one point only in the spacecraft. A compatible grounding network between Gemini B, Laboratory, and Titan III shall be designed to maintain this concept.

3.3.3.2.6.4 Electromagnetic Interference

Electromagnetic interference (EMI) of the Gemini B shall be minimized consistent with the requirements of SSD Exhibit 64-4. Reference paragraph 4.1.2.5.

3.3.3.2.7 Time Reference Requirements

3.3.3.2.7.1 Basic Time Reference

An electronic capability shall be provided to furnish accurate accounting of elapsed time, time-to-go, and time correlation. A reset capability shall be included.

3.3.3.2.7.2 Event Timer

A capability for providing short-term timing of function shall be provided.

~~CONFIDENTIAL~~

3.3.3.2.8 Pyrotechnic Requirements

3.3.3.2.8.1 General (U)

The Gemini B shall have the capability for actuating, severing, separating, deploying, sealing, and jettisoning by utilizing pyrotechnic devices.

3.3.3.2.8.2 Safety (U)

Actuation of pyrotechnic devices shall not endanger the crew or damage adjacent systems. Installation of pyrotechnic devices shall be so designated that the hazard to launch ground crews is minimized during assembly and checkout of the Gemini B. All possible precautions shall be taken to preclude inadvertent initiation of pyrotechnic devices. Electromagnetic Compatibility requirements for these devices must be consistent with SSD Exhibit 64-4. The requirements of AFWTRM 550-2 will be met by all pyrotechnic devices.

3.3.3.2.8.3 Effectiveness (U)

All functions requiring the use of pyrotechnic devices shall utilize either redundant devices or have an alternate mode of operation.

3.3.3.2.9 Landing Requirements

3.3.3.2.9.1 General (U)

The Gemini B re-entry module shall have the capability to return to the earth's surface by deployment of recovery devices. The capability for seat ejection during descent shall be provided.

3.3.3.2.9.2 Descent and Impact (~~C~~-4)

The rate of descent of the re-entry module shall be  $32 \pm 2$  fps at sea level for a weight of 4860 lb.

~~CONFIDENTIAL~~

3-95

~~CONFIDENTIAL~~

The water and sea state impact loads on the re-entry module shall not exceed the deceleration levels in the following directions:

Forward	30 g
Aft	30 g
Up	11 g
Down	15 g
Left	11 g
Right	11 g

3.3.3.2.9.3 Flotation (U)

Following water impact, the Gemini B shall float in a crew hatch-up position. Provisions for additional flotation gear to be manually secured to the Gemini B by recovery force personnel shall be provided.

3.3.3.2.10 Post-Landing and Survival Requirements

3.3.3.2.10.1 Location (U)

The means for location of the re-entry module and crew members after landing shall be provided. This location and capability shall include visual devices for both day and night operation as well as HF and VHF voice and VHF recovery beacon capability. Location aids in the re-entry module shall be operable for a post-landing period of 36 hr.

3.3.3.2.10.2 Flight Crew Safety (U)

Sufficient food and potable water shall be provided for a post-landing period of 48 hr. Equipment to permit flight crew survival outside the re-entry module either on water or land shall be provided. The Gemini B shall be capable of floating in water while maintaining an interior environment permitting crew survival inside the crew compartment for a continuous period of not less than 36 hr after touchdown in water.

~~CONFIDENTIAL~~

~~CONFIDENTIAL~~

3. 3. 3. 2. 11 Flight Crew Transfer Requirement

3. 3. 3. 2. 11. 1 Normal Mode (U)

Sufficient free volume shall be provided to permit either crewman to open, stow, and subsequently re-install and latch the transfer hatches. Hatch and tunnel size shall be large enough to preclude trapping of the crewman if emergency inflation of the suit occurs during transfer. Positive stowage of the transfer hatches shall be provided to prevent damage during transfer and on-orbit storage.

3. 3. 3. 2. 11. 2 Back-up and Emergency Modes (U)

The regular egress hatches used for backup extravehicular transfer shall remain closed after transfer of the last crewman. Provisions shall be made for opening and closing the hatches from inside and outside Gemini B while in a pressurized suit. Provisions shall be provided for handholds, etc. on the exterior of the Gemini B.

3. 3. 3. 2. 12 Flight Crew Equipment and Display Requirements

3. 3. 3. 2. 12. 1 General (U)

The design and arrangement of the flight crew station shall be based on seating two crew members of a size consistent with the requirements of paragraph 3. 3. 5 in a side by side arrangement. The crew members shall be clothed in MOL pressure suit assemblies.

3. 3. 3. 2. 12. 2 Displays and Controls (C-4)

Display and control capability shall be provided to permit the flight crew to monitor and manually control Gemini B functions consistent with the requirements stated herein. Display capability to satisfy the malfunction detection system (MDS) requirements (paragraphs 3. 3. 3. 2. 16 and 3. 3. 6) must be provided. Control provisions must be included to permit shutdown of the Titan III engines by the

~~CONFIDENTIAL~~

~~CONFIDENTIAL~~

flight crew while in the Gemini B. Capability to control the Laboratory Vehicle ACTS shall be provided. Pertinent Laboratory system status display capability and control of critical Laboratory functions shall be provided consistent with the requirements of paragraphs 3.1.1.1.5.5 and 3.3.2. Control provisions for safety of flight functions shall be operable by the crew in either vented or pressurized suits.

3.3.3.2.12.3 Flight Crew Seating (U)

Provisions shall be included for seating of the two-man flight crew in the proper position and with adequate restraint to minimize the effect of launch and re-entry acceleration forces. These seat provisions shall include the capability of successfully ejecting the crew members from the re-entry module for certain modes of launch and ascent phase abort, and for emergency landing.

3.3.3.2.13 Communications and Command Requirements

3.3.3.2.13.1 General (U)

The AFSSD developed Space-Ground-Link System (SGLS) suitably modified for Gemini B shall be used to provide the main functions of two-way voice communications, spacecraft to ground telemetry, tracking, and digital command from the ground. These functions shall be supplied only when the Gemini B is active. Provisions shall be made for inter-communication between the crew at all times. Recovery aids shall be provided.

3.3.3.2.13.2 Voice Communications (U)

In addition to SGLS, one UHF and one HF two-way voice communication system shall be provided. A capability for post-landing operations with a primary voice communication mode and a back-up beacon mode shall be provided.

~~CONFIDENTIAL~~

3. 3. 3. 2. 13. 3     Telemetry

A capability for spacecraft-to-ground real-time telemetry shall be provided. This telemetry capability shall be continuously available when in sight of a ground station during ascent, loiter, and re-entry phases. During the on-orbit phase, the telemetry capability shall be available on call. The Gemini PCM format shall be used. Suitable interface modifications shall be provided for integrating and establishing compatibility of SGLS with the Gemini instrumentations.

3. 3. 3. 2. 13. 4     Tracking and Recovery

SGLS and additional aids for flight phase radar tracking and for post-landing recovery location shall be provided. Radar tracking aids shall be capable of continuous operation during launch and re-entry phases and shall be compatible with C-band ground tracking stations. Post-landing recovery location aids capable of operating on the international distress frequency of 243 Mc shall be provided.

3. 3. 3. 2. 13. 5     Command

A capability for ground to spacecraft command transmissions and receptions shall be provided. The Gemini command format shall be used. Suitable interface modifications shall be provided for integrating and establishing compatibility of SGLS with the Gemini digital commands.

3. 3. 3. 2. 13. 6     Intercommunication

The capability for intercommunication between the crew shall be provided during all mission phases. These phases shall include those times when both crew members are in the Gemini B, when one crew member is in the Gemini B and the other crew member is in the crew transfer mode, and when one crew member is in the Laboratory



Vehicle. The system required for intercommunication shall be compatible with the systems required for vehicle to ground voice communications.

3.3.3.2.14 Flight Crew Training Equipment

Training equipment, as appropriate, shall be provided to accomplish Flight Crew Training in accordance with paragraph 3.3.12. Portions of the Gemini B procedures trainer shall be designed for integration into the MOL Mission Simulator.

3.3.3.2.15 Gemini B Peculiar Ground Systems

3.3.3.2.15.1 Gemini B Peculiar AGE

3.3.3.2.15.1.1 Design

The Gemini B segment peculiar AGE shall consist of OGE and MGE designed to support all Gemini B Segment operations from after final acceptance at the contractor's facility through launch. This Gemini B peculiar AGE shall be designed per the requirements established by this specification. Maximum utilization shall be made of existing or modified NASA Gemini designs. The Gemini B AGE utilized at VAFB shall be functionally identical to the AGE utilized at the contractor's facility and the AGE utilized during factory acceptance.

3.3.3.2.15.1.2 Performance

The Gemini B segment peculiar AGE shall include all the equipment necessary to transport, handle, store, verify, calibrate, check out, monitor, record, service and control the Gemini B segment. This AGE shall be capable of providing a means of (1) verifying the proper operation of the Gemini B segment to assure successful operation of all systems during all segment test and factory acceptance, (2) determining whether the Gemini B segment is operable within prescribed limits, and (3) identifying to the black box and/or replaceable component areas of failure or operation outside of prescribed limits. This

~~CONFIDENTIAL~~

AGE shall form a part of the OV AGE and will also support the integration of the Gemini B with the other elements of the OV and the Titan III. Fault isolation equipment at the launch site will be limited to that equipment necessary to isolate faults to the black box or replaceable component level. Detailed fault isolation and failure analysis within black boxes and/or components will be conducted at contractor/subcontractor plants.

3.3.3.2.16 Flight Crew Safety Requirements

3.3.3.2.16.1 General (~~C~~-4)

The flight crew safety contribution of the Gemini B shall include both that provided by the inherent safety of the Gemini B design when the system is operated in a normal manner and by the crew escape/mission abort systems and/or operating modes for abnormal system operation and malfunctions. Crew fatalities as defined here are those fatalities attributable to the mission phase prior to recovery and subsequent to SRM ignition.

3.3.3.2.16.2 Inherent Safety (~~C~~-4)

Inherent safety is provided by ensuring the compatibility of the Gemini B system and spacecraft capabilities with the conditions and environments imposed by normal operation and by the effectiveness of the systems and subsystems. The probability that a crew fatality will result from any kind of failure of the Gemini B shall not be greater than 0.001.

3.3.3.2.16.3 Safety During Mission Abort (~~C~~-4)

When an abort is required, the use of the abort/escape systems combined with the inherent safety of the Gemini B shall allow a probability of crew fatality no greater than that called out in the table below. The table shows the maximum allowable probability of crew fatality as a function of flight phase in situations in which an abort is required.

~~CONFIDENTIAL~~

3-101

~~CONFIDENTIAL~~

<u>Stage During Which Abort Occurs</u>	<u>Maximum Probability of Crew Fatality If An Abort is Required</u>
Stage 0 Operation	0.100
Any Other Launch Vehicle Stage Operation	0.020
Orbital Operations	0.001

The probability that the Gemini B shall cause a mission abort shall not exceed 0.0001 for the entire mission.

3.3.3.3 Functional Interfaces (U)

(Functional interfaces shall be listed here when defined by the cognizant Interface Control Working Group - ICWG)

3.3.3.4 Contract End Items (U)

(The contractor shall provide for incorporation in this paragraph a list of the Contract End Items by CEI specification number, nomenclature, and the CEI into which it installs. This paragraph shall list all end items being provided under these system segments.)

~~CONFIDENTIAL~~

~~CONFIDENTIAL~~

3.3.4 Mission Payload System Segment (C-4)

The Mission Payload System Segment shall utilize a Mission Module (unpressurized, ten feet in diameter and approximately 36 feet long) located aft of the Laboratory Module. Control and display consoles necessary to the operation of mission payloads will be accommodated within the pressurized section of the Laboratory Module as stated in paragraph 3.3.2.2.11.

The specifications of the Mission Payloads will be provided separately.

3.3.4.1 Allocated Performance and Design Requirements

3.3.4.1.1 Effectiveness

Effectiveness requirements for this segment are specified in paragraph 3.1.3.1.2.

3.3.4.1.2 Weight

The weight allocation for this segment is specified in paragraph 3.3.1.1.1.

3.3.4.1.3 Electrical Power

The electrical power allocation for this segment is specified in paragraph 3.3.1.1.2.4. The allocation per referenced paragraph shall be supplied to the Mission Payload Segment by the Laboratory Vehicle Segment. Mission Payload power requirements in excess of the allocation of paragraph 3.3.1.1.2.4 shall require a corresponding adjustment of the weights allocation given in paragraph 3.3.1.1.1.

~~CONFIDENTIAL~~

~~SECRET~~

SPECIAL HANDLING

3.3.4.2 Mission Payload Performance and Design Requirements

3.3.4.2.1 General

The purpose of this section of the specification is to present a definition of the Dorian System by defining and describing the major subsystems and components; defining the system specification tree and system segment list; and listing the contract and items.

Manned Flights

The Orbiting Vehicle is composed of the Gemini B System Segment, the Laboratory Vehicle System Segment and the Mission Payload System Segment.

Automatic Configuration

The Orbiting Vehicle consists of the Laboratory Vehicle System Segment and the Mission Payload System Segment (which includes the DRV Section).

3.3.4.2.2 Mission Payload System Segment Description

The Mission Payload System Segment includes the Mission Module Section, the Photographic Section, and the Data Re-entry Vehicle (DRV) Section. The Mission Module Section includes additional Dorian System equipment located in the Laboratory Module. The major Dorian System items are shown in Figure 3-7 for the manned automatic configuration and in Figure 3-8 for the automatic configuration.

The Dorian System consists of a high resolution optical reconnaissance sensor and suitable control, recording, and processing equipment. The image recording equipment will be dual frame cameras capable of photographing the target image at approximately one frame/second. Upon being reflected by a tracking mirror, the ground target image will pass through the photographic optics, consisting of a primary mirror, two folding mirrors, and a Ross corrector assembly, into the camera located in the Laboratory Module. The ground target will be tracked by the tracking mirror, servo-controlled by an on-board command and control system. Latest ground computed ephemeris information will be continuously updated using an accelerometer. Vernier Control of the tracking mirror will be provided utilizing star tracker and rate gyro subsystem together with an image motion detector. The stereo angle range of the tracking mirror will be  $+30^{\circ}$  to  $-40^{\circ}$  with an obliquity angle range of  $\pm 40^{\circ}$ .

Manned Automatic Configuration

The astronaut will have the capability of overriding the automatic tracking mirror control to minimize image motion at the center of the format or to center the particular point of interest within a given target area.

~~SECRET~~ SPECIAL HANDLING

SPECIAL HANDLING

~~SECRET~~

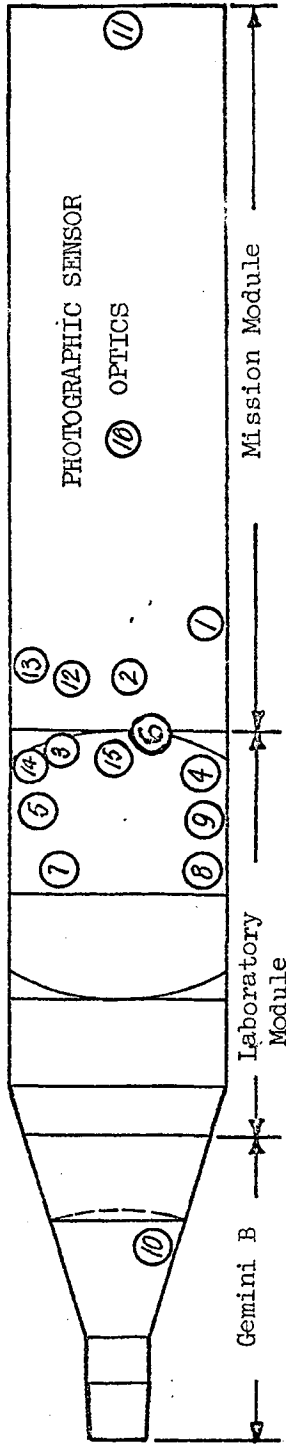

- 1. ENVIRONMENTAL CONTROL SUBSYSTEM
- 2. TRACKING MIRROR CONTROL SUBSYSTEM
- 3. CAMERA
- 4. ACQUISITION AND TRACKING SCOPES
- 5. PAYLOAD CONSOLES
- 6. MISSION CONTROL SUBSYSTEM
- 7. DRV STORAGE
- 8. DRV LAUNCHER
- 9. DATA READOUT SUBSYSTEM
- 10. FILM RECOVERY VIA GEMINI
- 11. MISSION MODULE STRUCTURE
- 12. INSTRUMENTATION SUBSYSTEM (VIA DESIGN LAB LINK)
- 13. STAR TRACKER & RATE GYRO SUBSYSTEM
- 14. IMAGE MOTION DETECTOR
- 15. AUTOMATIC OPTICAL ALIGNMENT SUBSYSTEM
- 16. PRIMARY OPTICS

\*Includes all circled items.

DORIAN SYSTEM\* (MANNED-AUTOMATIC CONFIGURATION)

Figure 3-7

~~SECRET~~

SPECIAL HANDLING

~~SECRET~~  
SPECIAL HANDLING

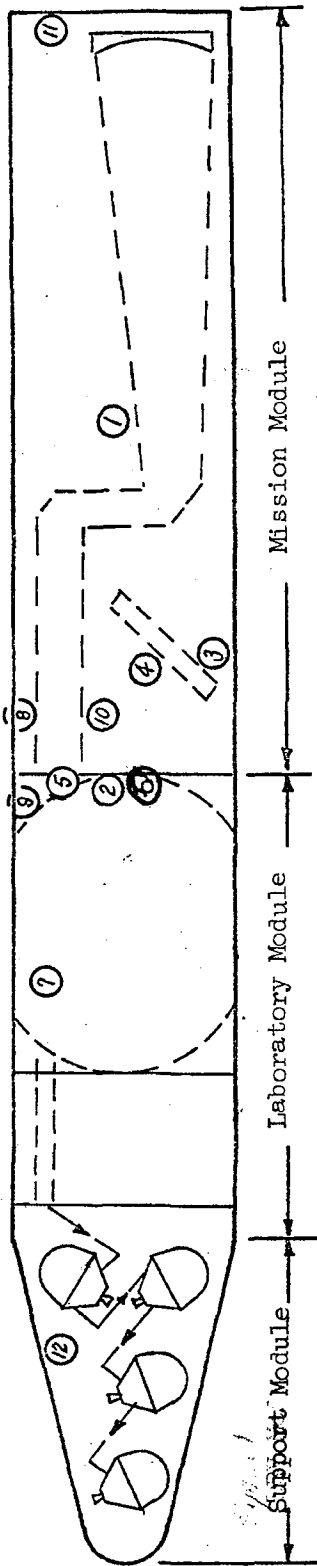

1. PRIMARY OPTICS
2. AUTOMATIC OPTICAL ALIGNMENT SUBSYSTEM
3. ENVIRONMENTAL CONTROL SUBSYSTEM
4. TRACKING MIRROR CONTROL SUBSYSTEM
5. CAMERA
6. MISSION CONTROL SUBSYSTEM
7. AUTOMATIC FILM TRANSPORT SUBSYSTEM
8. STAR TRACKER AND RATE GYRO SUBSYSTEM
9. IMAGE MOTION DETECTOR
10. INSTRUMENTATION SUBSYSTEM
11. MISSION MODULE STRUCTURE DESIGN
12. DRV SECTION

DORIAN SYSTEM\* (AUTOMATIC CONFIGURATION)

\*Includes all circled items.

3-6  
Figure 3-8

~~SECRET~~  
SPECIAL HANDLING

Normally, target photographic operations will be automatically controlled; however, during manned flights, the astronaut will be able to acquire the target using an acquisition and tracking scope having a zoom lens. A target cue display will be available to aid in target recognition. The astronaut will also have the capability to monitor (and, if desired, control) final target centering and tracking rate error reduction using the primary optical system.

The capability will be provided in the Laboratory Module for manned flights to process selected individual frames of photography through a readout system and relay selected portions of these frames to the ground. Recovery of the primary record will be by means of small Data Re-entry Vehicles (DRV's) launched from the Laboratory Vehicle and the Gemini B spacecraft. A more complete description of the Photographic Section may be found in 3.3.4.5.

Automatic Configuration

Data will be returned by means of four DRV's (larger than those of the manned version). These DRV's will be supported in and released from the Support Module which includes the nose cone of the vehicle.

3.3.4.2.3 Weights

The Mission Payload System Segment weight budget is as follows:

	<u>Manned-Automatic</u>	<u>Automatic</u>
Photographic Section*	4800	
Data Re-entry Vehicle Section	380	
Peripheral Equipment***	<u>1020</u>	
	8330	

\* Includes camera, visual optics, alignment and focus equipment, film transport, and film.

\*\* Includes weight of nose fairing and DRV launcher in laboratory.

\*\*\* Includes reconnaissance consoles (manned only) data readout system (manned only) acquisition and tracking system (manned only), star tracker and rate gyro subsystem, Image Motion Detector and other miscellaneous payload support equipment.

3.3.4.2.4 Electrical Power

Electrical power will be supplied by the laboratory fuel cells. The dynamic characteristics of the mission payload electrical system are (later). The on-orbit average power allocated for Mission Payload System Segment is \_\_\_\_\_ watts. Allowable peak transient are (later)



3.3.4.2.5 Disturbances Due to Mission Payload Equipment

The torque disturbances due to outgassing, magnetic materials and other sources of external torque shall not exceed \_\_\_\_\_ ft. lbs. or a total of \_\_\_\_\_ ft lb sec for the 30-day mission.

The torque disturbances due to internal moving parts shall be kept to a minimum. Examples of moving parts are the mirror, the film transport, the astronauts, doors and other pieces of equipment such as DRV's, tracking scopes, etc. The torque disturbances due to internal moving parts shall be kept to a minimum. Examples of moving parts are the mirror, the film transport, the astronauts, doors and other pieces of equipment such as DRV's, tracking scopes, etc. The changes in OV angular momentum required to put these devices into motion shall not exceed the following during the period beginning one minute before and ending immediately after an active photographic pass:

- Yaw angular momentum + \_\_\_\_\_
- Pitch angular momentum + \_\_\_\_\_
- Roll angular momentum + \_\_\_\_\_

The total accumulated magnitude of angular momentum changes which exceed these values outside of the period of an active photographic pass shall not be more than the following:

- Yaw angular momentum + \_\_\_\_\_
- Pitch angular momentum + \_\_\_\_\_
- Roll angular momentum + \_\_\_\_\_

3.3.4.2.6 System Coordinates

The Orbiting Vehicle coordinate system definitions for the manned and unmanned versions, are given in Appendix A

3.3.4.2.7 Design Considerations

Mission Payload design criteria shall be such as to minimize launch base test requirements and to maximize payload security.

3.3.4.2.8 Flight Termination System

There are no functional flight termination system requirements for the Mission Payload. Launch abort and equipment recovery will include security provisions for Dorian System equipments (e.g., target cues).

3.3.4.2.9 Explosive Devices, Squib Simulator, etc.

Chapter 10 of AFWTRM 550-2 provides guidance to range users regarding design, installation, and checkout of ordnance items. Generally, explosive devices must be designed to permit installation as late as possible during the pre-launch phase.

3.3.4.2.10 Launch Safety

The design of the MOL/Dorian System shall be such that hazards to personnel during the pre-launch, checkout, and launch operation is minimized. Applicable documents on ground safety are listed in Section 2.0 with the prefix letters SF. Particular attention is called to the WTR Range Safety Manual (AFWTRM 550-2).

3.3.4.2.11 Umbilicals

It shall be a design goal to minimize the use of umbilicals to the Mission Payload System Segment during launch pad integration and checkout. If possible, the Mission Module Segment power, instrumentation, air conditioning, and computer programming requirements will be provided via the Laboratory Vehicle AGE. Proper terminal equipment must be provided to maintain required mission security.

3.3.4.2.12 Weight and Balance

It shall be a design objective not to require weight and balance equipment at the launch base. Final weight and balance adjustment shall be performed during the mission module/laboratory module integration and checkout prior to shipment to the launch base.

3.3.4.2.13 Alignment

(later)

3.3.4.3 Mission Module Section

3.3.4.3.1 Mission Module Structure

(later)

3.3.4.3.2 Thermal Environment Control Subsystem

(later)

3.3.4.3.2.1 General

It is required that the environmental control system not limit the photographic sensor operation.

3.3.4.3.2.2 Ground Conditioning

(later)

3.3.4.3.2.3 Powered Flight

(later)

3.3.4.3.2.4 Orbital Flight

(later)

3.3.4.3.3 Command and Control Requirements

3.3.4.3.3.1 General

The Mission Control Subsystem (MCS) shall provide for the commanding of the cameras, optical equipment, and other mission module functions. The Satellite Control Facility shall be used to the maximum extent for the determination of the parameters used by the MCS. On-board data processing shall be used as required to meet performance objectives. The MCS shall be designed to support the Dorian System either manned or unmanned.

3.3.4.3.3.2 Main Optics Tracking

The MCS shall provide closed loop control of the tracking mirror. The accuracy and resolution of the digital interface with the motors and instruments shall be designed for compatibility with the mirror servomechanisms. The tracking equations and digital interface shall provide for control of the mirror with errors contributing no more than 0.07 percent to image motion. During a single forward to rearward track, the MCS shall provide for mono or stereo photography of a single target or a target cluster. Target cluster requirements are specified in Section 3.3.4.3.3.7.

3.3.4.3.3.3 Orbital Position Determination

The MCS shall determine the position of the vehicle on orbit by interpolating an ephemeris table. A description of the orbit spans required for photography shall be accepted from any SCF tracking station by the MCS. Without the use of on-board instrumentation, orbital positions as defined by the MCS during the photographic spans shall have the following two sigma accuracies  $1\frac{1}{2}$  revolutions after the orbit definition has been loaded ( $2\frac{1}{2}$  revolutions after the determination span):

In-track	0.2 mile
Cross track	0.1 mile
Altitude	0.1 mile

An in-track correction bias shall also be accepted from the tracking station. In addition, the output of an accelerometer shall be integrated to establish the in-track error resulting from drag. With proper accelerometer performance, the two sigma in-track error shall be no greater than 0.1 mile ( $2\frac{1}{2}$  revs after the determination span).

Manned Automatic Configuration

Manual hand controller inputs shall be accepted from the crewmen to correct the in-track and crosstrack reference.

3.3.4.3.3.4 Image Motion Compensation

By further processing the orbit definition (3.3.4.3.3.3) and accelerometer inputs, the image motion shall be determined to sufficient accuracy to reduce the image rate at the center of the format to less than 0.07 percent. An image motion detector shall be provided. The MCS shall provide information to the image motion detector equating to a V/h error no greater than one percent. The image motion detector shall return error signals or measurements.

As an objective, the image motion detector shall measure both the in-track image motion error and the cross component resulting from yaw error.

Manned Automatic Configuration

Manual hand controller inputs shall be accepted from the astronaut to correct image rates. These corrections shall apply to the orbit reference, and affect following targets. The processing of image motion detector inputs to the MCS shall be an astronaut option.

3.3.4.3.3.5 Payload Attitude Measurement

Two or more star trackers shall be integrated into the mission module. The mounts for these trackers shall be positioned and designed for

~~SECRET~~

SPECIAL HANDLING

the maximum correlation between the star tracker reference and the optics pointing reference. Two of the star trackers will normally be tracking during photographic operations. The specific stars to be tracked shall be determined by ground data processing. Assuming an in-track error no greater than that specified in 3.3.4.3.3.3 the star tracker system, shall establish the attitude of their mounting axis with respect to the local vertical and the orbit plane with two sigma errors no greater than 1.5 minutes. Prior to acquisition, the MCS shall point the axis of the tracker to the line of sight to the star with an error no greater than 2 degrees.

The number and reliability of the star trackers shall assure that the probability of two or more trackers working at the end of the mission is 0.95.

3.3.4.3.3.6 Camera Control

The MCS shall provide open loop adjustments and commands, and off-axis image motion compensation servo control. The open loop adjustments shall include exposure (slit control), focus (correction for slant range and focal length), and a cycle command. Either open loop or closed loop servo commands shall be provided to the platen and/or slit as required for across the format IMC. Calculations for this IMC control shall be performed by the MCS.

Error signals shall be accepted from a focus sensor and a boresight light tracker. The focus sensor shall provide signals correlating with the apparent error in focal length for the scene under observation. Open loop operations shall be provided by recording focus error signals for ground analysis and subsequent platen commands. In addition, the MCS shall provide for closed loop focus by filtering the error signal to test suitability of the scene, and then by automatically commanding platen adjustments.

The MCS shall accept error signals from the boresight light tracker for system alignment. When operating with a source of collimated light within the optical system, the MCS shall drive alignment servos to null the error. Both open loop and closed loop operation shall be provided. As an objective, the MCS also shall use the boresight light tracker to track a light source on the ground. Following ground processing of the error signals, the MCS shall accept an alignment matrix from the ground relating the star tracker reference to the apparent optical axis reference.

~~SECRET~~

SPECIAL HANDLING

3-80104.9

~~SECRET~~

SPECIAL HANDLING

The MCS shall provide information to the camera data lamps. This information shall include a convenient rev. and frame identifier, time which can be correlated to within one millisecond of GMT (post flight), the exposure setting, and information allowing the determination of the angle between the LOS to the target and the local vertical with an error no greater than 2 minutes of arc ( $2\sigma$ ).

Unmanned Version

The MCS shall provide a discrete to the camera system for looper replenishment. This discrete shall be issued at a time when the starting and stopping of the film cassettes does not adversely disturb system operation. Additional discretets shall be provided for film wrapup, cut, and seal.

Manned Version

The MCS shall provide control signals to select the film to be positioned for each exposure, or to tag the frames to be processed on-board.

3.3.4.3.3.7 Sequential Control

The MCS shall provide for the sequential control of the Mission Payload Segment. This function shall include the execution of real time commands within one second of their receipt, and the execution of stored commands within 200 msec. of the time indicated by their associated time label. Stored commands shall be employed for housekeeping tasks not directly related to photography.

During a single forward to rearward motion of the tracking mirror, the MCS shall sequence the events required to photograph a single target, or a cluster of targets. Nominally, a single target will be photographed in stereo with three different exposure settings. The various exposures will be taken to improve the resolution of both the highlights and the shadows. When photographing target clusters, the available time and camera cycle constraints may limit photography to the one exposure setting calculated by the MCS using sun angle and scene content information. The cluster or target definition provided by the ground shall specify the exposure ground rule, stereo angle, and specific target for each frame. Clustered targets may be defined as offsets to the first target in the cluster to be photographed.

SPECIAL HANDLING

~~SECRET~~

3 3784.10

~~SECRET~~

SPECIAL HANDLING

Manned Version

When photographing a target cluster, manual hand controller input correcting position for the first frame shall apply to all targets in the cluster. Rate corrections shall be accepted throughout the sequence.

3.3.4.3.3.8 Thermal Door Control

The MCS shall control the thermal door servos. The door positions shall be controlled to limit the heat energy entering the tracking mirror bay without obstructing the light from the target. The acceleration of the doors shall be controlled by the MCS to hold disturbance torques to an acceptable level. ←

3.3.4.3.3.9 Target Acquisition and Selection (Manned Flights)

Two acquisition and tracking scopes shall be provided to assist the astronauts in their selection of the target and the reduction of pointing errors. The MCS shall provide for the closed loop control of these two optical devices using an interface similar to that provided for the primary tracking mirror. Both astronaut stations shall have the capability to observe the image from either acquisition and tracking scope, or from the primary optics. Manual hand controller inputs shall be accepted from the astronaut to perform the functions listed in 3.3.4.3.3.3 and 3.3.4.3.3.4 and to slew the acquisition scopes in a manual search mode. The MCS shall store and process a matrix relating the axis of the main optical system to the axes of the two acquisition and tracking scopes.

Alternate targets (or target clusters) shall be available to the astronaut to permit the circumvention of weather. The selection of options for the target or cluster following any given target or cluster shall be prepared at the Mission Control Center. The target options shall be transmitted to the vehicle either as earth referenced coordinates, or as designators of targets stored in the vehicle.

Controls shall be provided for the designation of targets by the astronauts and for their comments relating to the estimated quality of the photography.

The MCS shall provide open loop commands to the astronaut cue system. These commands shall result in the automatic presentation of the target cueing aids required by the astronauts to center the targets or properly position the offset reference.

~~SECRET~~

SPECIAL HANDLING

**SPECIAL HANDLING**

~~SECRET~~

3.3.4.3.3.10 MCS Telemetry

Two data services shall be provided to the telemetry system from the MCS computer: real time diagnostic data and a stored mission reporting service.

Real time diagnostic data shall be provided at a rate between one and five kilobits per second. These data shall contribute to the analysis of control system performance. This diagnostic data shall include all control signals interfacing with the computer software.

The mission reporting service shall provide a summary of system operation during the photographic pass. This service shall be provided at a rate between 500 and 1200 bits per second to permit direct transfer to data lines between the tracking station and the Mission Control Center. Operational data on each photograph shall be included. In addition, critical instrumentation shall be reported as a backup to the vehicle telemetry recorder, the SGLS ground station, and the SCF data processing system.

3.3.4.3.3.11 Reliability

The MCS shall be designed to survive failure. After any single failure, the MCS shall be capable of supporting a productive mission. The equipment shall be organized to support an efficient test of the redundancy. It shall be a design objective that this redundancy be achieved with a minimum of additional equipment configured so that failure may reduce capability but not abort the mission.

3.3.4.3.4 Electrical Power and Distribution Subsystem

(later)

~~SECRET~~ SPECIAL HANDLING



~~SECRET~~ SPECIAL HANDLING

3.3.4.3.5 Data Readout Subsystem (Manned Flights only)

A readout subsystem shall be provided for the transmission of photographic information to the ground. The primary requirements for this system are quality and security. The secondary requirements are quantity, economy, astronaut convenience, and reliability. A standard SCF S-band data link operating at 20 MBPS shall be employed.

3.3.4.3.5.1 Resolution

As a design objective, the data readout subsystem shall scan and transmit pictures with no loss in resolution. It is required that the loss in photographic resolution due to scanning and digitizing shall be no greater than 20 percent.

3.3.4.3.5.2 Quantity

The readout subsystem shall read out the maximum area of photographic material consistent with the other requirements in Section 3.3.4.3.5. It shall be a design requirement to read out 5 square inches in 5 minutes, and a design goal to read out 100 square inches in 5 minutes.

3.3.4.3.5.3 Operational Employment

Operation of the readout subsystem shall require a minimum of the astronaut's time. The scanner shall accept portions of various pictures which have been edited by the astronaut. It shall be a design goal that the astronaut not be required to assist the scanning operation over a tracking station.

The number of tracking stations equipped for readout will be a function of the ground equipment costs. Decryption and processing of data at the tracking station is not required, but may be performed if it contributes to quality or economy.

3.3.4.3.5.4 Security

Encryption equipment will be provided GFE.

~~SECRET~~ SPECIAL HANDLING

NOT APPROVED FOR  
RELEASE 11 JULY 2016

3.3.4.3.6 Acquisition and Tracking Scopes (Manned Flights Only)

Two acquisition and tracking scopes for redundancy and efficiency of target acquisition shall be an objective. The optical axes of the scopes can be positioned from +70° to -40° in-track and +45° crosstrack. Position and tracking rate data from the scopes will be fed to the computer for main optics acquisition.

3.3.4.3.6.1 Magnification Range

The scope image will be a 5X magnification with a zoom capability to give 25X. It shall be a design objective to also provide 1X for wide field of view.

3.3.4.3.6.2 Field of View

The apparent field of view will be 20°, but at the magnification of the eyepiece (5X) the astronaut will see a 4° field.

3.3.4.3.6.3 Alignment

The scopes will have the capability of being boresighted with the main optics while on-orbit.

3.3.4.3.6.4 Display

The view from each scope will be available at both astronaut stations.

3.3.4.3.6.5 Scope Control

The acquisition and tracking scopes will be servo driven using independently controlled positioning servo systems. The input signals will be supplied from the MCS and from the controlling astronaut's ~~hand controller~~ motion. Each astronaut will have control capability for both scopes. The gimbal arrangement and optical-dynamical effects should be as close as possible to the Tracking Mirror Control. The torquer and equilization design will give consideration to the astronauts abilities and should maximize efficient use of this capability. Consideration of a quickened reticle, wave form input spectrum and noise effects should be included in order to simplify the tracking task, provide specified accuracy, damping and response for the overall subsystem.

**SPECIAL HANDLING**

~~SECRET~~

3.3.4.3.7 Astronaut Viewing Capability (Manned Configuration)

A lookout capability will be provided, permitting the astronauts to scan the entire volume beneath the Orbiting Vehicle, 360° in azimuth, at elevation angles up to and including at least 90°. At a magnification of 1X, the field of view shall be at least 20°. The lens system will also have to capability to zoom to a magnification of 5X. The capability to determine the relative position of objects within the field of view to within \_\_\_\_\_ degrees in both azimuth and elevation is required.

Consideration shall be given to providing the above capability in the Acquisition and Tracking Scope or with a separate instrument. (Also see (3.3.2.2.9.7)(3.2.2.7.1))

~~SECRET~~

**SPECIAL HANDLING**

~~SECRET~~

SPECIAL HANDLING

3.3.4.4 Data Re-entry Vehicle Section

3.3.4.4.1 General Requirements

Manned-Automatic Configuration

The Data Re-entry Vehicle Section (DRVS) shall include one to three Data Re-entry Vehicle (DRV's) and shall support, house, and protect the DRV's, a launcher tube, and auxiliary electrical and mechanical equipment required to control DRV separation.

The DRVS launcher tube shall be adequate to contain one re-entry vehicle approximately 22 to 33 inches in diameter at its mounting base and 130 lbs weight with 20 - 60 lbs of data capsule capacity. The data capsule is defined as the film container in the DRV. The launcher shall be located at the proper re-entry angle assuming a normal level attitude of the Orbiting Vehicle at separation.

The DRVS shall be located in the Laboratory Module (LM) which shall provide the required space and the environmental control as specified herein.

In the event a DRV does not eject from the DRVS launcher, the capability shall exist to retrieve the film and re-seal the DRVS launcher as required.

Automatic Configuration

The DRVS\* shall include four DRV's and shall support, house, and protect the DRV's and auxiliary electrical and mechanical equipment to control DRV separation and provide environmental control. The DRVS shall also serve as the nose cone of the launch vehicle and shall be designed to withstand the launch and ascent environment.

The DRVS shall be adequate to support four DRV's approximately 33" in diameter, 43" long, and 370# weight (including film). The DRV's will be supported at the proper re-entry angle assuming the OV roll axis is normal to the local vertical at separation.

3.3.4.4.2 DRVS Structure and Packaging

a. Accessibility

(1) DRV Installation and Removal

(Later)

\* In the automatic configuration the DRVS is contained in the Support Module.

~~SECRET~~ SPECIAL HANDLING

~~SECRET~~

SPECIAL HANDLING

(2) Retro-rocket Ignitor-Installation

The safety problem associated with the solid retro-rocket will possibly require shipment of the assembled DRV prior to installation of the rocket ignitor or initiator. The design of the rocket ignitor shall be such as to allow shipment of a unit as completely assembled as possible under air transport restrictions. However, if required because of shipping regulations, provisions shall be made to install the ignitors or initiators at the pad without disassembling the DRV, and without invalidating any previous testing.

3.3.4.4.3 Pyrotechnics

All pyrotechnic-operated devices will have redundant or back-up pyrotechnics. Redundant pyrotechnics shall be fired from independent electrical circuits. All pyrotechnic devices shall be hermetically sealed and qualified to show no degraded performance after 60 days under simulated orbital environmental conditions.

3.3.4.4.4 DRVS Environmental Control (Thermal)

a. General

The environmental control design shall maintain the DRV within the proper temperature range. This will be accomplished, using both passive and active thermal control as required.

b. Ground Conditioning

The ground temperature range and humidity limits are as per Section 3.4. The cleanliness limits are (later).

c. Orbit

The temperature limits (later) shall be maintained.

3.3.4.4.5 Data Recovery Vehicle Subsystem Weight Budget

The total weight of each DRV (exclusive of film) as defined herein shall not exceed 130 lbs for the manned version or 315 lbs for the unmanned version.

3.3.4.4.6 Minimum Acceptable Reliability Level

The DRVS equipment shall have a minimum acceptable reliability level of (later).

3.3.4.4.7 Prelaunch Testing

At the launch pad, the DRVS will be capable of all necessary prelaunch tests as part of an overall system test while fully assembled

~~SECRET~~

SPECIAL HANDLING

~~SPECIAL HANDLING~~

~~SECRET~~

and mated with the Laboratory Module. Command of this testing will be through the vehicle command and control system and monitoring will be done via telemetry. The functions to be tested and the test procedure will be the same as those during the final acceptance tests at the factory.

3.3.4.4.8 Data Re-entry Vehicle (DRV)

The DRV shall be complete de-orbiting re-entry vehicle. While in orbit, it will maintain the proper environment for the film and will supply status data to the telemetry subsystem. Its capabilities (with manual assistance)\* include: sealing as required; preparation for de-orbit and re-entry; and separation from the DRVS support structure.

After separation from the DRVS support structure,, the DRV will transmit a radio frequency signal to provide re-entry status data and to act as a retrieval aid. During the atmospheric re-entry phase, the DRV will provide environmental protection of the film. After re-entry, the DRV will descend via a parachute designed for aerial retrieval. At parachute deployment, the DRV will provide the required lights to assure night retrieval. The DRV will survive water impact and the retrieval aids will remain active until the sink subsystem is activated.

The DRV will contain a system for self-destruction if it does not re-enter within a designated area.

a. Detail Performance Requirements

(1) General

Manned-Automatic Configuration

The DRV will be fully accessible while attached to the DRVS support structure. It will be capable of mechanical disassembly without demating from the DRVS support structure and without disconnecting electrical circuits. The capability for replacement of any item or component while on the launch pad shall exist. The design of pyrotechnic installations shall permit the verification of such installations without disassembly of the DRV.

Automatic Configuration

The DRV will be fully accessible while attached to the Support Module structure. It will be modularized and designed for interchangeability so that an unacceptable DRV can be replaced in the vehicle without detrimentally affecting the vehicle DRV performance separation, weight, and, balance constraints. The capability for replacement of any item or component

\* In manned configurations

~~SECRET~~ SPECIAL HANDLING

337104/88

~~SECRET~~

SPECIAL HANDLING

of the DRV in the OVAB shall exist. The design of pyroelectric installations shall permit the verification of such installations without disassembly of the DRV.

(2) Ascent

Manned-Automatic Configuration

During ascent, the DRV will maintain its interior pressure at or above the Laboratory Module level.

Automatic Configuration

During ascent the DRV will maintain its interior pressure at (later)

(3) Orbit

The DRV and its components will be designed and qualified to withstand at least 60 days in a vacuum space environment without degrading its subsequent operational capability or reliability. External surfaces of the DRV shall be capable of being treated with thermal paint.

Manned-Automatic Configuration

While in the environment of the Laboratory Module, the operational DRV will maintain its data capsule internal temperature within the range  $75 \pm 15$  degrees F.

The DRV launcher will be pressure sealed so that in the event of loss of Laboratory Module pressure, the leak rate from the launcher will be less than 1%/day. Manual pressure relief shall be provided for controlled access to the DRV launcher.

During orbit and all subsequent mission phases, the DRV will provide a light-tight container for the film.

Automatic Configuration

The DRV and DRVS design shall be such that the film is maintained at a temperature of  $75^{\circ} \pm 15^{\circ}$ F. The DRV and film chute shall be pressure sealed as necessary so that the Laboratory Module pressure can be maintained at 1.5 psi.

The DRV and film chute shall provide a light-tight environment for the film.

(4) Preparation for Deboost

The DRV will require no more than two electrical signals to prepare if for deboost. These two signals may be used for such purposes as activating re-entry batteries, starting timers, beacons, or arming programmers.

Manned-Automatic Configuration

The operations required for placing the data capsule

3-104.198

~~SECRET~~

**SPECIAL HANDLING**

~~SECRET~~

Automatic Configuration

The DRV and film chute design shall permit serial loading of the four DRV's without a requirement for film splicing.

(5) Data Re-entry Vehicle Separation

The DRV will be separated while the OV roll axis is aligned with the flight path within a tolerance of  $\pm 2$  degrees (three sigma) about the pitch, and yaw OV axes. The OV will have maximum rates of  $\pm .02^\circ$ /second (three sigma) about all three axes. In an emergency mode, the OV attitude tolerance at DRV separation will be  $\pm 10^\circ$  (three sigma) about each OV axis.

Manned-Automatic Configuration

The DRV separation and push-off subsystems are to be considered part of the launcher subsystem. The launcher subsystem shall spin the DRV as required for stabilization.

Automatic Configuration

The DRV separation and push-off subsystem are to be considered part of the DRVS. Spin-up of the DRV will be provided by the DRV spin-de-spin system after separation of the DRV from the Orbiting Vehicle.

(6) Deboost

After separation and spin-up, the DRV will deboost itself from orbit by firing the retro-rocket, and de-spinning, if required, to a rate which will allow the proper re-entry angle and proper parachute deployment. The deboost operation shall result in no damage or detrimental effects to the Orbiting Vehicle, including the primary payload optics. Approximately at the time of separation, the DRV will commence transmitting an RF signal modulated to provide minimum operational decision data and which will act as a tracking and retrieval aid. This RF signal shall be of sufficient power and characteristics as to be received by existing tracking stations, ships, and recovery aircraft at a line-of-sight range. A redundant tracking aid shall be required. This deboost must be successful under worst case DRV unbalance. The deboost must also be successful from the emergency mode attitude limits, including both N-S and S-N re-entry.

(7) Re-entry

The DRV will provide thermal and environmental protection for the film during atmospheric re-entry. The DRV will be designed

~~SECRET~~

**SPECIAL HANDLING**  
3-104-20



so that in-gassing will occur upon atmospheric re-entry and in such a manner as to cause no damage to the film payload. The film will not be subjected to temperature in excess of 110°F.

(8) Deboost and Re-entry Dispersions

In the case of proper film handling and with the OV under the control of the primary stabilization system at DRV separation, the impact point of the DRV will be within a rectangle  $\pm 75$  nm in-track and  $\pm 8$  nm crosstrack (three sigma). Impact is defined as the latitude and longitude of the DRV upon descending to 50,000 ft. In the case where the vehicle is in the emergency mode, the successful dispersion rectangle will be increased by a factor of 2 in each dimension.

(9) DRV Destruction Subsystem

In the event the DRV overshoots the predicted impact point, it will contain a mechanism for destroying itself and its data by natural means so that it is beyond recognition upon reaching the earth. This destruction may occur upon recognition of the overshoot or at eventual orbit decay and re-entry. This destruction will not take place for an overshoot of the predicted impact point of less than 1400 nm and is mandatory in the event of an overshoot exceeding 2600 nm.

(10) DRV Recovery

(a) Primary Mode - Aerial Recovery

Final descent will be controlled by a parachute subsystem. This parachute will provide a minimum of 20 minutes of descent time on the parachute before water impact. The descent rate at 10,000 feet will not exceed 25 ft/sec under standard atmospheric conditions. The parachute system will be compatible with RCG aerial recovery gear. Night recovery capability is required.

(b) Secondary Mode - Water Recovery

Water recovery requires the radio retrieval aid and a flashing light system. If not covered in the air, the DRV will survive water impact and float such that the radio retrieval aid and the flashing light system are still effective. The radio frequency aid will be capable of operation for a minimum period of 24 hours after separation. The flashing light will continue to operate for approximately 12 hours after separation.

**SPECIAL HANDLING**

~~SECRET~~

(11) DRV Sink Subsystem

The DRV will continue to float for a minimum of 50 hours. The sink subsystem will flood and sink the capsule after a maximum of 90 hours in the ocean. A design requirement of this subsystem is simplicity and a negligible probability of premature operation.

(12) Post Re-entry DRV Retrieval

After aerial or water recovery, the US Government will provide shipment and control of the data capsule. A means of de-activating the DRV will be provided. A shipping container will be required to house the data capsule during shipment and handling after retrieval. The DRV design will be such as to facilitate removal of the film from the DRV in complete darkness.

b. DRV Electrical Subsystem

All power required in the DRV will be supplied by the Laboratory Module until receipt by the DRV of that signal which will be used to activate the DRV battery during the deboost sequence.

The electrical design of the DRVS, consisting of harnessing and components to control and monitor the DRV status and separation, shall meet the electrical design requirements of Section 3.4.

c. Special Requirements

(1) Supplemental Telemetry System

(later)

d. Orbit, De-orbit, and Re-entry Conditions

The DRV shall be capable of being de-orbited properly from any position on the following orbits.

Orbit Perigee Altitude	70 nm to 90 nm
Eccentricity	0 to 0.025
DRV Orientation	One optimum to be selected by DRV Contractor
Orbit Plane Inclination	From 65° to 125°
Orbit Duration	60 days

~~SECRET~~

**SPECIAL HANDLING**

3-104-221  
3-107-27

~~SPECIAL HANDLING~~

~~SECRET~~

e. Data Re-entry Vehicle Reliability Requirements

The reliability design objectives are defined for operation during the period of time from launch vehicle liftoff through completion of recovery operations. Equipment design and component selection shall take cognizance of these reliability goals. The DRVS contractors shall consider reliability improvements through redundancy (and appropriate use of the astronaut in the manned version).

The reliability goals demonstration requirements shall be as follows:

(1) Reliability Goals

Manned-Automatic Configuration

(later)

Automatic Configuration

(later)

3.3.4.4.9 Separation Subsystem

The DRV shall be ejected so as to place it in the correct attitude and spin stabilized for ignition of the retro-rocket.

~~SECRET~~

SPECIAL HANDLING

3.3.4.5 Photographic Section

3.3.4.5.1 General

The Photographic Section contains optical, mechanical, thermal, electrical, and structural components necessary to perform high quality, stereo, photographic reconnaissance.

The available volume for photographic section use is 10 feet in diameter (to maintain structural continuity with the Titan booster) and 35 feet long. Local areas of protuberance may exceed this diameter.

The optical system of the payload (see Figure 3.3.9) consists of a 70 inch aperture, [REDACTED] focal length Ross telephoto lens having a  $0.54^\circ$  semi-field angle. The optical axis is approximately parallel to the longitudinal axis of the Mission Module which contains the payload. The Mission Module and payload are unpressurized. A 70-inch diameter, circular, flat tracking mirror is located in front of the lens at the forward end of the Mission Module. The tracking mirror is capable of pointing the line-of-sight  $\pm 40^\circ$  in roll (left and right of the X-Z plane),  $30^\circ$  forward in pitch and  $40^\circ$  aft in pitch. The tracking mirror is gimballed in two axes and is servo driven to slew, to follow computed target tracking rates, and to respond to position and rate change inputs inserted by a target tracker or by an astronaut.

Frame cameras utilizing  $9\frac{1}{2}$  inch wide film are located at the end of the Ross corrector barrel at the Laboratory Module side of the bulkhead. The cameras may take a sequence of up to ten photographs of each target, nominally within approximately  $\pm 15$  to  $-15$  degrees fore and aft (stereo) angles. Three different exposure settings are planned for each target. The nominal sequence rate is 1 frame per second. The total primary camera film supply shall be sufficient to obtain 15,000 frames of photography per 30-day mission. The 15,000 photographs may be apportioned by command between one photograph per target to 10 photographs per target.

The Mission Module provides a viewport which allows the primary optical beam to be moved through the required obliquity and stereo angles for photography. Viewport doors are provided for thermal protection during non-photographic periods.

Manned-Automatic Configuration

The Ross corrector barrel of the optical system is above and parallel to the optical axis of the primary mirror. Light is diverted from the optical system into a visual optics barrel which is parallel to the Ross corrector barrel. A zoom eyepiece at the end of the visual optics and within the Laboratory Module allows the astronaut to observe and track the target during photography. Magnifications of [REDACTED] are provided.

Figure 3-9

OPTICAL SENSOR BASIC CONFIGURATION

(Later)

~~SECRET~~

SPECIAL HANDLING

Assemblies in the Laboratory Module which are required for the manned reconnaissance operation are the Pre-editor and Processor, Film Viewer and Editor, and the Film Scanner and Readout. Also essential to photography are the 2 astronaut consoles with TV displays of the acquisition telescope fields, target cue displays and a hand controller for target centering and rate correction of the tracking mirror and acquisition scopes. Auxiliary photographic equipment includes a 16 mm sequence camera which looks through the primary optics.

3.3.4.5.2 Operational Requirements

The Photographic Section shall be capable of both northbound and southbound photography during a single mission and shall meet the specified resolution and total smear limit under the specified conditions. The altitude range for photography shall be 70 to 230 nm. Other aspects of the mission orbital envelope for photography are specified in Section 3.1.1.4.4.

It shall be an operational requirement to photograph as many targets as possible consistent with high quality stereo photography.

3.3.4.5.3 Camera

The camera system consists of the mechanical, electrical, and optical elements necessary to position the film and properly expose it. The system shall consist of cameras capable of providing a circular image on 9.5" wide aerial film. The film shall be transported across the platen between exposures and held in place during exposure (or moved if across the Format IMC is required). The film holding system shall be of such a design that system performance will not be degraded by film surface deformation.

Film transport from the storage reels, positioning on the camera platen, and transport to the take-up reels shall be automatically initiated after each exposure. The time between completion of one exposure to the allowable start of another shall be 1.0 second or less.

The local exposure time is defined as the time specified to expose a picture element. The frame exposure time is the time required to expose a photographic frame to all scene and data information. The nominal local exposure time will be 1/200 sec for S0-362 film. An exposure range will be provided for all sun elevation angles down to 5°. The nominal frame exposure time shall be 0.2 sec in accordance with the requirements on the number of frame/target.

~~SECRET~~

SPECIAL HANDLING

3-10-76  
3-10-76

SPECIAL HANDLING

~~SECRET~~

The Mission Control Subsystem shall be capable of providing pre-programmed sequences of from one to ten or more photographs. These sequences shall be programmable as to exposure and may contain up to three exposure levels to obtain  $\pm 1$  stop exposure range.

The position of the camera mount shall be controllable to provide \_\_\_\_\_ inches of focus correction. The camera shall be designed to accommodate the equipment necessary for recording data on the  $9\frac{1}{2}$  inch film.

#### Manned-Automatic Configuration

The system shall also be capable of providing and identifying one frame of photography/target for on-board processing with no loss of photographic information.

#### 3.3.4.5.4 Optical Design/Performance Requirements

This section describes the requirements on the primary photographic and visual systems only. Performance requirements for the sequence camera are contained in Section 3.3.4.5.7.

#### 3.3.4.5.4.1 Primary Optics

The final image shall be photographic negative on type SO-362 film. The orbital quality measurement method and quality requirements for the primary image are as follows:

##### a. Measurement Method

The quality of the primary image shall be measured by photographing during flight, one or more specifically prepared test targets having several tri-bar patterns of standard Air Force design and having a calibration gray scale of known reflectivity. During the performance check the brightness of the various areas of the target will be measured at the target with pre-calibrated instruments. Simultaneously with these measurements the optical sensor shall photograph the target from satellite altitude. Not less than four photographs shall be taken.

#### Manned-Automatic Configuration

Two of the latent images will be processed with on-board equipment according to specifications in Section 3.3.4.5.9. Two of the latent images will be returned to earth via a DRV Gemini B. Resolution readings and density measurements of the processed record shall be made by an astronaut and reported at the earliest opportunity.

~~SECRET~~

SPECIAL HANDLING

3-10427

~~SECRET~~

b. Quality Requirement

Analysis of the film records together with measured brightness values shall permit the calculation of apparent contrast at the entrance pupil. A calculated apparent contrast between 1.5 and 3.0 shall imply acceptable test and atmospheric conditions for a quality check. Within this range on contrast, the system shall be capable of resolving tri bars as indicated in Figure 3-10. The conditions of this figure form a part of this specification. Performance tradeoffs for conditions outside this range shall be supplied by the photographic sensor contractor.

3.3.4.5.4.2 Visual Optics (Manned Configurations)

The performance and testing requirements are as follows:

a. Performance

Magnification		continuously variable
Apparent Field	40°	full field.
Flight Transmission	___	% for visual relay only
Resolving Power	___	lines/degree
Central 10°	___	lines/degree
Rest of Field	___	lines/degree
Eye Relief	___	nm

b. Testing

Magnification of the visual relay shall be checked before it is assembled to the primary optical system. It can be checked in a test fixture containing a reticle with known spacings. The angle subtended by these spacings can be measured with a clinometer looking through the eyepiece. The magnification of the telescope can be computed if the magnification of the visual relay and the focal length of the primary mirror are known.

Apparent field can be measured on the same test fixture as used for magnification by having reticle marks to indicate the field size for a given magnification.

Light transmission of the visual optics relay shall be measured with a photometer.

Resolving power of the telescope shall be measured with the complete system correctly aligned. Since this only happens in orbit,

~~SECRET~~ SPECIAL HANDLING  
3-104-4828



Figure 3-10

RESOLUTION VERSUS CONTRAST

(Later)

~~SECRET~~  
SPECIAL HANDLING

the performance test must be made by looking at test charts on the ground. This can be done during the photographic testing.

Eye relief shall be measured by attaching a pupilometer to the eyepiece to locate the exit pupil.

3.3.4.5.5 Recording Handling

3.3.4.5.5.1 Film Requirement

The nominal film width shall be  $9\frac{1}{2}$  inches. The primary reconnaissance film shall be Kodak Special High-Definition Aerial Film (Estar Thin Base) Type SO-362. The vehicle shall carry 13,000 feet or 230 lbs of this film for photographic operations exclusive of leader requirements and expected waste.

3.3.4.5.5.2 Black and White

Manned Configuration

The primary film SO-362 will be loaded into 5 supply reel cassettes and loaded into the camera manually and over operational lighting conditions. Each supply reel shall satisfy film requirements for 6 days operation. The number of targets acquired per pass shall not be limited by supply or take-up capacity. The exposed record shall be wound into take-up cassettes and manually removed from the camera under operational lighting.

Automatic Configuration

The primary film, SO-362 will be loaded into one supply reel threaded, through the camera and into the multiple take-up cassettes.

3.3.4.5.5.3 Color and Special Films (Manned Configuration)

The vehicle shall be capable of carrying additionally supply cassettes of color, night, or special films. For use other than in main camera see Section 3.3.4.5.9.

3.3.4.5.6 Photographic Format

The photographic image shall be a 9.4 inch diameter circular format centered with respect to the edges of the film. The interframe spacing shall be 1 inch, giving a frame length of 10.4 inches.

~~SECRET~~

SPECIAL HANDLING

3-104/390

Areas outside the image, the four corners, are available for edge data recording on the film. Edge data to be recorded shall include the following:

a. Binary Code

- (1) Greenwich Civil Time (accuracy  $\pm 1$  millisecond)
- (2) Vehicle Attitude (accuracy  $\pm 3$  minutes)
- (3) Tracking Mirror Stereo and Obliquity Angles (accuracy  $\pm 3$  minutes)
- (4) Film Exposure Time (8 levels)
- (5) Revolution Number
- (6) Frame Sequence Number (begin with zero for each revolution)

b. Alphanumeric Symbols

- (1) Revolution Number
- (2) Frame Sequence Number

All foregoing data will be recorded when the slit is in center format position. The binary data shall also be recorded on magnetic tape for transmission to ground.

In addition to above data, other suitable exposures and markings will be made on the film to show:

- (a) Fiducial marks
- (b) Frame center mark
- (c) Interframe mark
- (d) Revolution end mark
- (e) Frame vernier dots (1/200 sec spacing with motion of slit)
- (f) Mark or magnetic imprint for special frames

3.3.4.5.7 Sequence Camera (Manned Configurations)

A motion picture camera shall be provided in the visual optics system. This system will provide 16 frame/sec color motion pictures of the image displayed to the astronaut. The operational light for this camera shall be obtained without introducing any flicker into the astronaut's view, and it shall not limit the luminance of his visual image to less than \_\_\_\_\_ ft-lamberts at nominal scene brightness and to less than \_\_\_\_\_ ft-lamberts at any time during primary payload operations.

~~SECRET~~  
SPECIAL HANDLING

The camera shall provide sufficient film to provide coverage for 1500 targets during the mission. For each target, the sequence camera shall activate during primary off-on periods. Exposure control shall be automatic.

The sequence camera shall provide \_\_\_\_\_ feet coverage with \_\_\_\_\_ nominal ground resolution at nadir. The sequence camera format shall contain only data required for time correlation with the primary camera.

Operation of the sequence camera outside of shutter actuation shall not require the attention of an astronaut at any time during a photographic pass, and the camera shall be designed to require as little attention as feasible from the astronaut.

3.3.4.5.8 Film Processor (Manned Configuration)

3.3.4.5.8.1 General

The Laboratory Module shall be provided with an on-board processor which will process selected frames of SO-362 primary record for the purpose of on-board photographic reconnaissance and readout to the ground for quick access to reconnaissance information.

3.3.4.5.8.2 Acquisition

The primary record to be processed shall be obtained without endangering the continuity of primary record to be processed on the ground. Provision shall be made for identifying frames to be on-board processed and provision shall be made for removing these frames and transporting them to the processor without restriction to the lighting conditions in the Laboratory Module.

3.3.4.5.8.3 Processor

The on-board processor shall be capable of processing 50 pictures/day with no more than 5 minutes/picture total processing time. The processor shall not degrade resolution by more than 15 percent of the resolution obtainable with optimum ground processing. Chemical contaminants shall not in any way affect the quality of the recovered primary record and shall in no way endanger the health, safety, or comfort of the astronauts. The processor shall be capable of operation in nominal Laboratory Module lighting conditions and shall produce a dry photograph suitable for viewing and readout.

~~SECRET~~ SPECIAL HANDLING 3-10432  
7-109-32

~~SECRET~~  
SPECIAL HANDLING

~~SECRET~~

3.3.4.5.8.4 Viewer

A viewer shall be provided to examine the on-board processed record. The viewer shall be large enough to accommodate two frames of photography. The viewer shall be equipped with a binocular microscope of magnification range \_\_\_\_\_ to \_\_\_\_\_ capable of displaying the scene to its full resolution limit. The microscope shall be capable of scanning an entire image.

3.3.4.5.9. Dual Camera System (Primary and Secondary) (Manned Version)

It shall be a design objective to provide, in addition to the primary camera, a secondary frame camera which uses the primary optics and has the same image format as the primary camera. Simultaneous photography with both cameras is not a requirement. Photographs will be made with the secondary camera by either diverting the light beam from the primary to secondary camera platen, or by replacing the primary camera with the secondary without a change in the light beam. The purpose of the secondary camera is to provide the capability of photographing the target with color and/or films other than that used for primary photography. Thus, the same target can be photographed with both the primary high resolution black and white film and a different film such as color. Astronaut access to the secondary camera is a requirement.

The camera system shall be capable of changing films and necessary filters with a loss of no more than one frame of photography/change.

3.3.4.5.10 Environmental Control

3.3.4.5.10.1 General

The environmental control subsystem shall provide proper temperature control for the Photographic Section during all phases of vehicle operations. Passive thermal control shall be used to the greatest practical extent. Ground conditioning of the Photographic Section shall be performed by internal convective cooling and electric heating as required.

3.3.4.5.10.2 Ground Conditioning

Ground conditioning during all phases of ground test (including factory system test and pad operations) will employ an internal ducting system to maintain the required thermal control.

~~SECRET~~

SPECIAL HANDLING

~~SECRET~~

The temperature range and humidity limits are  
(later). The cleanliness limits are (later).

The ground conditioning system shall provide an environment that will allow acceptable thermal conditions for payload operation within five hours after launch.

3.3.4.5.10.3 Powered Flight

The temperature and humidity limits are as per Section 3.3.2.2.6.2.4. The cleanliness requirements are (later).

Vent paths shall be sized consistent with the design pressure differentials. The allowable pressure differentials on the aft laboratory bulkhead are +5 to -1/2 psi differential (P laboratory-P mission module). The allowable compartment pressures for the forward booster compartment are \_\_\_\_\_.

3.3.4.5.10.4 Orbit

A passive system of environmental control shall be employed to the greatest practical extent. This system shall utilize thermal control coatings, insulation, and component placement. Active environmental control shall be automatic.

The temperature and humidity requirements are as per Section 3.3.2.2.6.2.4. The cleanliness requirements are (later).

Coating deterioration due to the space environment shall be minimized and must be compatible with the mission life and system performance requirements.

The optical performance degradation with door open time shall be minimized. The design goal is to obtain no measurable degradation for 10 minutes of active operation with the maximum sun angle ( $\beta = 0$ , 21 June).

3.3.4.5.11 Mechanical Mounting

3.3.4.5.11.1 General

Suitable mechanical mountings for the Photographic Section shall be supplied for all phases of the payload operations. The mounting shall not in any way affect or alter the performance of the Photographic Section.

~~SECRET~~

SPECIAL HANDLING  
3-104.34

**SPECIAL HANDLING**

~~SECRET~~

3.3.4.5.11.2 Ground Handling

Mechanical mounting of the Photographic Section during testing shall be performed in such a way that the test results shall be independent of the test method.

3.3.4.5.11.3 Powered Flight

The Photographic Section shall be mounted in such a way that launch forces cannot endanger the Photographic Section or its subsequent performance.

3.3.4.5.11.4 Orbit

The mechanical mountings during flight must be such that no performance degradation results. The mountings shall allow strain free support of the payload at all times during the useful orbital life of the vehicle. The payload shall be aligned to within + \_\_\_\_\_ degrees of the vehicle X axis before alignment and shall be held within + \_\_\_\_\_ degrees after alignment.

No focus shift of the image on the record and no alignment shift of any of the payload elements shall occur due to the payload mountings.

3.3.4.5.12 Performance Prediction

Performance prediction is a tool that is useful for design purposes. For the Dorian System, performance prediction shall be accomplished by the method described in Attachment 2.

~~3.3.4.6~~ Aerospace Ground Equipment Requirements

3.3.4.6.1 In-Plant Test Equipment

(later)

3.3.4.6.1.1 Alignments

(later)

3.3.4.6.1.2 Special Purpose Testing

(later)

3.3.4.6.2 Handling and Transportation Equipment

(later)

3.3.4.6.2.1 Handling

(later)

3.3.4.6.2.2 Transportation

(later)

**SPECIAL HANDLING**

~~SECRET~~

3-3-104-355

- 3.3.4.6.3 Launch Base Test Equipment  
(later)
- 3.3.4.6.4 Ground Power and Electrical Distribution  
(later)
- 3.3.4.6.5 Aerospace Vehicle Servicing Equipment  
(later)
- 3.3.4.6.6 Ground Environmental Control Equipment  
(later)
- 3.3.4.6.7 Launch Monitoring and Control Equipment  
(later)
- 3.3.4.6.8 Safety Equipment  
(later)
- 3.3.4.6.9 Miscellaneous Aerospace Ground Equipment  
(later)
- 3.3.4.7 Mission Payload Functional Interfaces  
(Physical and functional interfaces shall be listed here when defined by the cognizant Interface Control Working Group - ICWG).  
Manned Version  
(later)  
Unmanned Version  
(later)
- 3.3.4.8 Contract End-Item List (CEI)  
Figures 3-11 and 3-12 illustrate the top level specification trees for the major end items comprising the manned and unmanned versions, respectively, of the Dorian System. Detailed end-item critical lists shall be prepared and maintained by each applicable contractor in accordance with his contract. Detailed specifications shall also be prepared, submitted to the Procurement Agency for approval, and subsequently maintained by the contractor for each end-item to be furnished.  
The applicable CEI lists are as follows:
  - 3.3.4.8.1 Mission Module Section Breakdown (later)
  - 3.3.4.8.2 Photographic Section Breakdown (later)
  - 3.3.4.8.3 DRV Section Breakdown (later)



~~SECRET~~

SPECIAL HANDLING

NRO APPROVED FOR  
RELEASE 1 JULY 2015

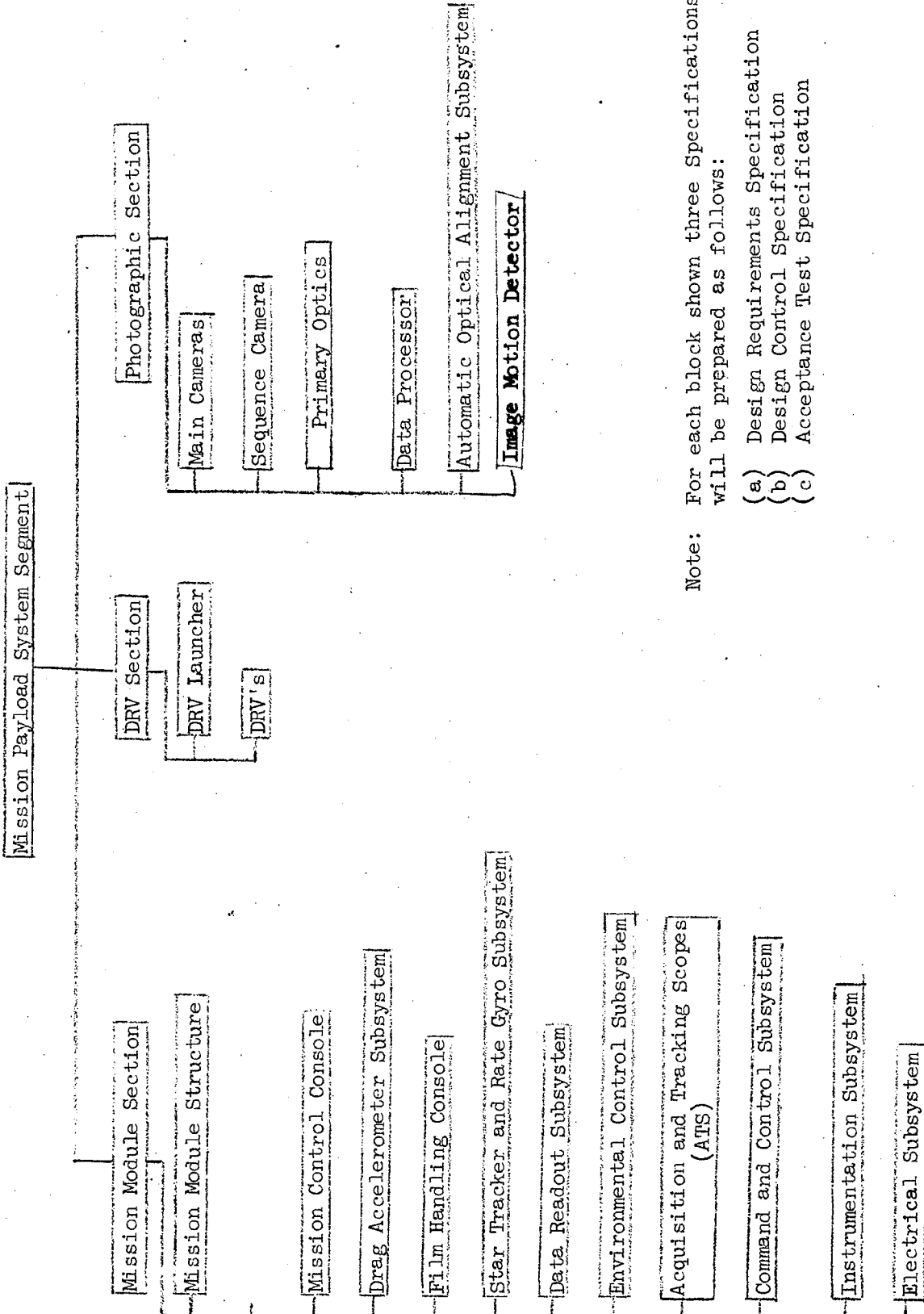

Note: For each block shown three Specifications will be prepared as follows:

- (a) Design Requirements Specification
- (b) Design Control Specification
- (c) Acceptance Test Specification

DORIAN SYSTEM SPECIFICATION TREE (MANNED VERSION)

Figure 3-11  
3-11

~~SECRET~~

SPECIAL HANDLING

3-104.37

SPECIAL HANDLING

~~SECRET~~

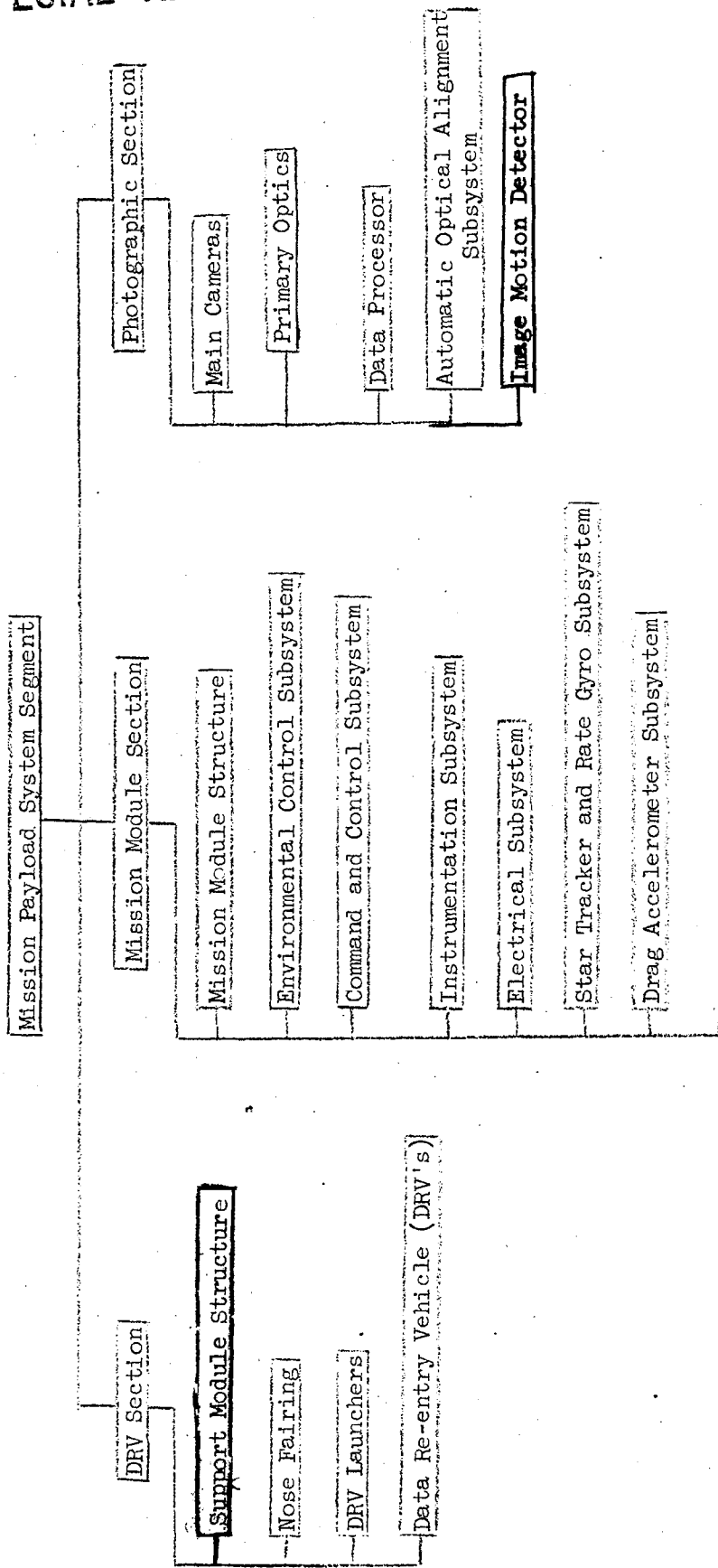

Note: For each block shown three Specifications will be prepared as follows:

- (1) Design Requirements Specification
- (2) Design Control Specification
- (3) Acceptance Test Specification

DORAIN SYSTEM SPECIFICATION TREE (UNMANNED VERSION)

Figure 3-12  
3-12

~~SECRET~~

3-104.38  
SPECIAL HANDLING  
3-104.38

~~CONFIDENTIAL~~

3.3.5 Crew Equipment System Segment (U)

This system segment defines the crew equipment requirements for performance of the MOL mission.

This section covers equipment for both intravehicular and extravehicular tasks, performed both with and without a pressure suit (both pressurized and unpressurized).

3.3.5.1 Allocated Performance and Design Requirements

3.3.5.1.1 Effectiveness (U)

Effectiveness requirements for this segment are specified in paragraph 3.1.3.1.2.5.

3.3.5.1.2 Weight (C-4)

For Crew Equipment design purposes, each crew member shall weigh 138 - 192 lb. The basic flight suits, together with portable oxygen supplies and umbilicals, shall not exceed 94 lb. Extravehicular equipment, including spare suits and umbilicals, portable environment systems, tools, tethers, and portable illumination sources, shall not exceed 220 lb. Flight crew test and monitoring equipment for both biomedical and human performance tests shall not exceed 520 lb, phasing down to a 95 lb weight target for later flights. Personal equipment, such as clothing and personal hygiene, shall not exceed 75 lb.

3.3.5.1.3 Volume (U)

Baseline functional volumes for Laboratory Vehicle design for the human operator shall be based upon anthropometric data using 10-90 percentile men by weight and by height. Both shirtsleeve and suited (pressurized and unpressurized) modes shall be considered. Storage volume for back-up suits, clothing, medical treatment, and personal items shall be provided.

~~CONFIDENTIAL~~

3-105

~~CONFIDENTIAL~~

3.3.5.1.4 Extravehicular Equipment

3.3.5.1.4.1 Pressure Suit Assembly (U)

The pressure suit assembly (PSA) includes the basic garment, with integral thermal and micrometeoroid protective provisions "anti-g" protection, helmet, gloves, communications, bioinstrumentation, plus recovery, flotation, survival and rescue equipment attached to the pressure suit.

During extravehicular operations, the PSA shall be provided with crew atmosphere control requirements through an umbilical and environmental control system components.

The PSA shall provide adequate mobility in shoulders, arms, hands, waist, hips, and knees to conduct all suited tasks planned for the MOL mission. The helmet shall provide undistorted visibility, portable illumination, protection from both ultraviolet and infrared radiation by the use of a removable visor, and micrometeoroid protection. The PSA shall provide protection against both radiated and conducted heat from direct, reflected, and surface contact, between the limits of  $-100^{\circ}\text{F}$  to  $+200^{\circ}\text{F}$ . Micrometeoroid protection shall be provided integrally in the PSA.

Each member of the primary and back-up crews shall be provided two PSA during each mission, one for primary and one for back-up use. Each PSA shall be custom-fitted to the individual flight crewman.

3.3.5.1.4.2 Auxiliary Extravehicular Equipment (C-4)

The major equipment items to be used in conducting the extravehicular operations, in addition to the PSA, are an umbilical type Environment Control System, personal VHF transceiver, and devices for traversing the OV surface such as handholds and tether belt. Capability for visually monitoring an extravehicular crew member shall be provided in the Laboratory.

3-106

~~CONFIDENTIAL~~

3.3.5.1.5 Intravehicular Operations (U)

Basic operations in the Gemini B will consist of flight operations during ground checkout, launch, orbital injection and insertion, Laboratory activation, de-orbit and recovery and shall be conducted in an unpressurized suit during non-emergency operations. Emergency operations for the same profile may utilize a pressurized suit. Routine Laboratory operations shall be conducted in shirtsleeve protective clothing.

3.3.5.1.5.1 Intravehicular Operations Equipment (U)

Restraining and locomotion devices shall be provided to permit the crew members to effectively operate at and move between various work and living stations in the vehicle. Such devices shall employ both fixed base and moving base restraint concepts as required to facilitate all operations and maintenance tasks. Standard and special tools with tool and component support shall be provided for maintenance and repair tasks. Comfortable restraint devices for sleeping shall be provided that occupy minimum volume both in use and during storage.

3.3.5.1.5.2 Flight Crew Clothing and Accessories (U)

Personal equipment, other than the PSA, shall be provided for the flight crew (e.g. body covering, footgear, gloves, tethers, eye protection devices, shaver, personal hygiene gear and first aid equipment). The intravehicular shirtsleeve clothing shall allow for essential body functions (including proper thermal transfer properties), skin health and hygiene, and shall be constructed of materials and characteristics of no-lint, appropriate strength, appropriate moisture absorbance and transfer, and soil and fire resistance. All clothing and accessories shall be consistent with Laboratory Vehicle requirements.

3.3.5.2 Peculiar Performance and Design Requirements

3.3.5.2.1 Orbital Operations Aids

3.3.5.2.1.1 On-board Technical Data (U)

The flight crew shall be provided with readily accessible technical data on systems, equipments, and procedures required to perform (e.g. using equipment, collecting data), in the operational and maintenance functions.

3.3.5.2.1.2 Crew Activity Programing (U)

The activities of the flight crew required for vehicle operations in performance of mission operations and tests on a given flight, and for personal maintenance (e.g. eating, sleeping, exercise) shall be programmed for each flight to achieve maximum mission effectiveness. Such programing shall contain alternative paths and the capability for reprograming crew time to accommodate alternate mission profiles or contingencies on a real or near real time basis with the crew participating in alternative sequence decisions.

3.3.5.2.2 Nutritional and Metabolic Requirements (U)

Atmosphere and thermal control requirements, together with water and waste management specifications, are included in the Environmental Control and Life Support Subsystem of the Laboratory Vehicle Segment.

3.3.5.2.2.1 Crew Energy Outputs (U)

A nominal energy output of 3000 kilocalories (kcal) per man per 24 hour cycle will be distributed as follows: 8 hr sleep at approximately 75 kcal per hour per man; two 30-min periods per man of physical work and/or exercise at 600 kcal/hr; 15 hr of other duty functions at approximately 120 kcal/hr. The EC/LS system should be designed to accommodate these thermal loads without depending on positive man heat storage during work or exercise periods, nor depending upon negative man heat storage during sleep periods. The system should also normally limit evaporation from the crewman to nominal figures

of 45 cc/hr except during exercise periods when an evaporation rate of 1000 cc/hr is allowable for a combined respiratory and skin water loss of 500 cc during a 30 min exercise period.

3.3.5.2.2.2 Food Composition

The 3000 kcal diet shall consist of a minimum of 70 g of protein, (carbohydrate and fat to be defined) and fortified with vitamins and minerals and having a calcium content less than 500 mg.

The food shall be carried in a dehydrated state; efficient, zero-g qualified food preparation, packaging, and dispensing procedures shall be provided. Food and water-handling systems shall provide for simple and effective means of recording specific food intake by nutrient type and calories.

3.3.5.2.2.3 Water Requirements (U)

Total water provision shall be  $3200 \pm 300$  g per man-day, including the water used to reconstitute the food for the liquid diet. Potability standards, including U. S. Public Health Service requirements and associated control measures, shall be established for water use during the entire mission. Water for food preparation and drinking shall be provided at 155°F and 55°F, respectively.

3.3.5.2.3 Personal Hygiene (U)

General skin hygiene shall be preserved by a simplified system of moist skin scrubbing. Oral hygiene shall be accomplished by water and brush without dentifrice. Particulate matter (beard, nail clippings, etc.) shall be aspirated and trapped.

3.3.5.2.4 Flight Crew Test and Monitoring

3.3.5.2.4.1 Biomedical Tests (U)

Equipment shall be provided to obtain in-flight data from both the flight crew and from the environment to which it is exposed. Prerequisites to the in-flight test program include acquisition of essential pre-flight and post-flight baseline data and extensive ground-based

testing to understand as fully as possible the physiological mechanisms of "simulated" weightlessness and the explicit parameters selected for in-flight measurement.

Provision shall be made for measurement of the following functions considering the effects of weightlessness, environmental loads, and body demands: (1) blood volume, pressure and flow; (2) the electromechanical behavior of the heart; (3) fluid and electrolyte levels and balance; (4) gastro-intestinal function and nutritional status; (5) metabolism of selected body materials, e. g., calcium and protein; (6) respiratory mechanics and rate of energy metabolism; (7) nervous system functions; e. g. muscle strength and coordination, general mental status; (8) body mass. Important associated environmental parameters shall be measured, including physical and tissue equivalent radiation measurements.

#### 3.3.5.2.4.2 Biomedical Monitoring (U)

The biomedical test equipment specified in 3.3.5.2.4.1 shall contain biomedical monitoring equipment to be used for flight safety monitoring in the Laboratory during all flights. These measures shall include continuous heart rate plus EKG, blood pressure, temperature, and respiration rate on schedule and on demand.

The baseline scheme for monitoring during launch and re-entry will consist of the basic NASA Gemini monitoring scheme. This includes 2 leads of EKG, blood pressure, respiration profile, and oral temperature.

#### 3.3.5.2.4.3 Crew Performance Tests (U)

The flight crew shall be tested on a set of standardized tasks integrated into a computer-driven, control-display test console designed to assess human performances related to aerospace vehicle and payload operations. The test profile shall include memory, vigilance monitoring, intellectual processes, and sensory-motor performances.



3.3.5.2.4.4 Man-Equipment Design Validation (U)

Flight crew performance shall be validated by the use of direct (TV, voice, recordings, and photographs) and indirect (flight data analysis, logs, and debriefings) measures.

3.3.5.2.5 AGE

3.3.5.2.5.1 Crew Support (U)

Facilities shall be available at or near the launch and recovery areas to house and transport crew members and to provide the necessary medical support, including prelaunch and post-flight medical evaluations.

3.3.5.2.5.2 Pressure Suit (U)

Ground support facilities shall be provided at locations wherever suit usage is contemplated.

3.3.5.2.5.3 Flight Crew Test and Monitoring (U)

AGE shall be provided as required for crew test and monitoring equipment.

3.3.5.3 Functional Interfaces (U)

(Functional interfaces shall be listed here when defined by the Cognizant Interface Control Working Group-ICWG.)

3.3.5.4 Contract End Items (U)

(The contractor shall provide for incorporation in this paragraph a list of the Contract End Items by CEI specification number, nomenclature, and the CEI into which it installs. This paragraph shall list all end items being provided under these system segments.)

~~SECRET~~

3.3.6 Titan III System Segment (U)

The Titan III Launch Vehicle consists of two seven segment 120" dia solid rocket motors and a two stage core vehicle as defined in SSBD 65-22. Basic requirements for performance and reliability are specified in this section.

3.3.6.1 Allocated Performance and Design Requirements

3.3.6.1.1 Minimum Payload Performance (3 SAR)

The Launch Vehicle shall be capable of launching a 32,000 lb Orbiting Vehicle into a reference 80 degree inclination 80/130 n mi elliptical orbit with perigee between 30° and 50° North latitude, without yaw steering from WTR. Payload decrements for greater inclination angles and yaw steering to meet range safety requirements should be subtracted from the above value. Estimates of such decrements associated with orbit inclinations other than 80° and/or yaw steering requirements are tabulated below.

<u>Orbit Inclination</u>	<u>Payload Decrement</u>
*80°	430
*82°	500
*84°	620
*86°	800
88°	1020
90°	1250
95°	1790
97°	1980
100°	2230

\*Yaw steering predicated on estimated range restrictions.

~~SECRET~~

3-113

~~SECRET~~

3.3.6.1.2 Insertion Accuracy (~~S-3~~ SAR)

The required insertion accuracy from a reference 80/130 n mi orbit shall be as follows:

3 $\sigma$  Insertion Accuracy

	Primary Guidance	Secondary Guidance
Inertial Velocity (tangential velocity)	12 fps	20 fps
Inertial Flight Path Angle	0.05 deg	0.1 deg
Altitude	1 n mi	2 n mi
Out-of-Plane Velocity	10 fps	300 fps
Out-of-Plane Position	0.5 n mi	10 n mi

3.3.6.1.3 Launch-on-Time Probability (~~S-4~~)

The Titan III system segment (AGE, Launch Vehicle, and facility) shall have a 0.90 probability of meeting a one hour window on any one of three successive days specified two weeks in advance of the scheduled launch date.

3.3.6.1.4 Effectiveness (~~S-4~~)

The Launch Vehicle shall have a probability of successfully accomplishing a launch countdown (Final 30 sec) of 0.93. The probability of accomplishing a successful launch through orbit insertion shall be 0.97.

3.3.6.1.5 Launch Restrictions (U)

3.3.6.1.5.1 The Flight Vehicle shall be capable of being launched in 99 percent winds aloft and ground winds at WTR as defined in Meteorological Note No. 2, Atmospheric and Wind Design Criteria for PMR, Titan IIIIX/Agema, Martin Company/Denver, dated 7 August 1964.

3.3.6.1.5.2 Visual Abort Mode (U)

Visual monitoring of the Launch Vehicle, and abort warning during the lift off and clearing of the launch complex shall be provided.

~~SECRET~~

~~SECRET~~

3.3.6.1.6 System Monitoring During Ascent (U)

A capability to monitor critical events and system status during ascent shall be provided to the Gemini B and mission control.

3.3.6.1.7 Orbiting Vehicle Separation (U)

The OV shall provide propulsive capability for the Stage II/OV separation. Redundant separation signals and separation devices will be supplied by the Launch Vehicle contractor. Backup will be provided by crew initiation capability. During separation, tip-off rates shall not exceed 2 deg per sec about any axis. The separation mechanism shall not induce detrimental shock or contaminants which could significantly degrade mission payload performance.

Requirements for thermal protection of the Titan III/M Mission Module interface area from flight termination exhaust plume impingement effects shall be determined.

3.3.6.1.8 Trajectory Constraints (U)

The dispersed 3 sigma ascent trajectory shall not exceed MOL system constraints.

3.3.6.1.9 Induced Oscillations (U)

The Launch Vehicle longitudinal oscillations will not induce sustained oscillations in the OV/Booster Interface in excess of 0.25g peak-to-peak in the frequency range of 5 to 30 cps.

3.3.6.1.10 Yaw Steering ~~(S-3)~~

The Launch Vehicle shall be capable of being yaw-steered during the powered portion of flight to meet the requirements specified in Paragraph 3.1.1.1.3.1. Pre-programmed orbital inclination inputs shall be accepted up to 24 hours before launch.

3.3.6.1.11 Perigee Placement ~~(S-3)~~

The Launch Vehicle shall accept a programmed positive insertion flight path angle ( ) up to 0.4 deg with a granularity of no more than 0.05 deg.

3.3.6.2 Peculiar Performance and Design Requirements

3.3.6.2.1 Malfunction Detection System (U)

A Malfunction Detection System (MDS) shall be provided to sense impending catastrophic or degrading failures. MDS paths and signals

~~SECRET~~

~~SECRET~~

shall be redundant. Escape shall be manually initiated; however, provisions shall be made for both automatic and manual thrust termination during Stage 0 flight.

3.3.6.2.1.1 Abort Warning (U)

Sensors, logic, and displays shall be provided to meet MOL system criteria for crew abort evaluation and decision.

3.3.6.2.2 Backup Guidance and Control

3.3.6.2.2.1 Redundant Guidance System (U)

The Gemini B IGS shall be used as a back-up to the Titan III system IGS for all stages of powered flight. Both automatic and manual switchover and switchback capability shall be provided.

3.3.6.2.2.2 Redundant Flight Control Systems (U)

Redundancy shall be provided in the flight control system.

3.3.6.2.3 Safety Criteria (C-4)

The Launch Vehicle systems, including the airborne and ground (real time) malfunction detection systems, shall be designed to meet the following criteria:

- (a) Between solid motor ignition and orbit insertion, the probability of a failure with a warning time\* less than 3.0 sec, plus undetectable failures, shall not exceed 1.8 per thousand flights.
- (b) Between 40 and 90 sec of powered flight, the failure rate with a warning time\* between 0.5 and 6 sec shall not exceed 3.2 per thousand flights.
- (c) Verification of an orbit lifetime of at least two orbits or generation of an abort signal or  $\Delta V$  requirements shall be provided.

\*Warning time is defined as the time between signalling the spacecraft of need to abort and either (1) start of structural breakup in the Launch Vehicle, or (2) exceeding ejection system or other spacecraft constraints.

~~SECRET~~

~~SECRET~~

- (d) Autonomous detection of guidance malfunctions on board the Titan III shall be provided after loss of range tracking (elevation angle <5 deg).

3.3.6.2.4 Performance Constraints (U)

The Launch Vehicle shall be constrained to the following nominals:

- (a) Maximum dynamic pressure shall not exceed 900 psf
- (b) Maximum acceleration during Stage 0 shall not exceed 3.29g
- (c) Maximum heating integral goal for critical Launch Vehicle stations shall be  $100 \times 10^6$  ft-lb/ft<sup>2</sup>

3.3.6.3 Functional Interfaces (U)

(Functional interfaces shall be listed here when defined by the cognizant Interface Control Working Group-ICWG)

3.3.6.4 Contract End Items (U)

(The contractor shall provide for incorporation in this paragraph a list of the Contract End Items by CEI specification number, nomenclature, and the CEI into which it installs. This paragraph shall list all end items being provided under these system segments.)

~~SECRET~~

3-117/118

3.3.7 Facilities System Segment

Design and construction of new and/or modified existing facilities shall satisfy the requirements of the MOL System as defined in this specification and in applicable Facilities Criteria Documents.

The facilities covered in this section encompass those facilities necessary to support the MOL development program and MOL operations from receipt of the segments at VAFB through launch of the MOL and recovery of the Gemini B. New facilities shall be provided only as required; maximum use shall be made of existing facilities modified as required.

3.3.7.1 Allocated Performance and Design Requirements

Required facilities for MOL System operations include the Initial Launch Capability (ILC), an Orbiting Vehicle Assembly Building (OVAB) an Engineering and Operation Facility, an Operational Readiness Unit, The Contractor Support Facility (CSF), Hazardous Handling Building, Pyrotechnic Storage Building, Miscellaneous Administration Building, and an Operational Training and Evaluation Facility, all to be located at VAFB. Facilities for storing and processing flight vehicle segments, components and spares, shall meet the requirements for function, safety and environments including contamination control, as specified under the provisions of \_\_\_\_\_. In addition, Mission Control at STC Sunnyvale and appropriate communication networks and facilities are required.

3.3.7.2 Peculiar Performance and Design Requirements

3.3.7.2.1 Initial Launch Capability

The MOL system will be integrated and launched from the ILC system at the VAFB.

3.3.7.2.1.1 Launch Pad

The MOL launch pad facilities shall provide an environmental enclosure for the entire Orbiting Vehicle while on the Titan III launch Vehicle, suitable parking areas for the Orbiting Vehicle AGE vans and fluid servicing units, and adequate services for the support of Orbiting Vehicle launch operations. Means shall be provided to effect the safe removal of the flight crew to at least 800 ft from the Gemini B in the

event a potentially dangerous condition arises between the time the flight crew enters the spacecraft and solid motor ignition. Facilities shall be located with consideration for the provision of a clear landing area as required for the flight crew in case of launch abort.

3.3.7.2.1.2 Launch Control Center

The ILC Launch Control Center (LCC) and connecting cable ways and ducting between the AGE vans and the Launch Control Center shall accommodate the MOL System AGE installation. Communication lines connecting the launch complex and the Launch Control Center shall satisfy MOL system requirements.

3.3.7.2.2 Industrial Area

Use of VAFB industrial area facilities by the Orbiting Vehicle prior to entering the ILC shall be minimized. New facilities or modifications to existing facilities shall be provided as follows:

3.3.7.2.2.1 Engineering and Operation Facility

Engineering and Operation, and Contractor Support Facilities shall be provided for the individual segment contractors and Air Force and Aerospace personnel.

3.3.7.2.3 Orbiting Vehicle Assembly Building

A facility shall be provided for the receipt, inspection, assembly, and checkout of the OV. Provisions shall be made for vertical assembly and checkout of the OV, including the pre-launch installation of pyro-technical and ordnance devices. Additional facilities shall be provided for the AGE required to conduct individual segment tests and to perform an integrated OV test.

3.3.7.2.3.1 Receiving, Inspection and Storage Facilities

A clean room area shall be provided in the Orbiting Vehicle Assembly Building for the receipt and inspection of individual segment portions



~~CONFIDENTIAL~~

of the OV system, which will be subsequently integrated and checked out. Sufficient area shall be provided for necessary AGE and personnel to perform subsystem tests required to align, calibrate, or adjust the appropriate systems. Area shall be provided for the storage of critical space components and elements as required.

3.3.7.2.3.2 Orbiting Vehicle Subsystem Maintenance Area (U)

An Orbiting Vehicle subsystem maintenance area shall be provided for possible modifications and/or maintenance found necessary on subsystems that are removed from the OV. Areas in the existing OVAB buildings shall be used for this function, where possible.

3.3.7.2.4 Pyrotechnic Receiving, Test, and Storage Facilities (U)

A pyrotechnic receiving, test, and storage test facility shall be provided at a location remote from the OVAB for receiving and testing of Orbiting Vehicle explosive devices. Provision shall be made for installation of explosive devices on the OV at the launch pad.

3.3.7.2.5 Bench Support Areas (U)

Bench support areas shall be provided for test equipment required to support design modifications, to determine the accuracy of spares, to detect malfunctions, and to support a limited maintenance and repair capability at VAFB. Areas in the ILC and/or existing VAFB buildings shall be used for this function, where possible.

3.3.7.2.6 Mission Control (C-4)

Facilities shall be provided at the Satellite Test Center (STC) at Sunnyvale, California for housing all powered flight and Mission Control equipment for display and control, data retrieval and storage, computation, on-orbit flight planning and changes, mission analysis, and biomedical support. Equipments necessary for the interconnection of the Mission Control with the LCC, telemetry receiving stations, mission simulation facility, range safety and range control, and range tracking station communications nets shall be installed.

~~CONFIDENTIAL~~

3-121

~~CONFIDENTIAL~~

3.3.7.2.7 Operational Training and Evaluation Facility (S-4)

Facilities shall be provided in the Operational Training and Evaluation Facility to house the necessary flight crew equipment, training equipment, physiological evaluation equipment, and a complete mission simulator which will operate in conjunction with Mission Control, the WTR, and the world-wide tracking network.

3.3.7.2.8 Operational Readiness Unit (U)

Facilities in the Operational Readiness Unit shall be provided at VAFB to furnish suitable living accommodations for primary and back-up flight crews, as well as key mission personnel. Space shall be provided for approximately eight flight crew members and 12 key personnel continuously on duty. This facility shall be located relatively close to operational training and evaluation facility.

3.3.7.2.9 Bioastronautic Operational Support Unit (Deleted)

3.3.7.3 Functional Interfaces (U)

(Functional interfaces shall be listed here when defined by the cognizant Interface Control Working Group-ICWG.)

3.3.7.4 Contract End Items (U)

(The contractor shall provide for incorporation in this paragraph a list of the Contract End Items by CEI specification number, nomenclature, and the CEI into which it installs. This paragraph shall list all end items being provided under these system segments.)

~~CONFIDENTIAL~~

3.3.7.5 Mission Payload Facility Requirements

Adequate provisions shall be made in the checkout, maintenance and launch areas for Dorian environmental and special security requirements. The provisions of FED-STD-222 are applicable to areas provided for servicing the mission payload.

3.3.7.5.1 Communications

Peculiar Mission Payload launch base communications requirements shall be established in such a manner that all required pre-launch and launch operations can be conducted with required security.

~~CONFIDENTIAL~~

3.3.8 Launch Operations System Segment (U)

The Launch Operations System Segment essentially covers all functions, techniques, and procedures that take place in the immediate geographical area of the launch site. It encompasses items involving the flight hardware and flight crew, and extends from their receipt at the launch site until lift-off of the Flight Vehicle from the launch site.

In addition, the activities within this segment depend upon the completion of the design, construction, and acceptance of the launch base facilities described in the Facilities Systems Segment. A further requirement is the design, installation, checkout, and acceptance of the AGE/OGE as an integrated system capable of performing pre-launch and launch verification tests on both the integrated OV and the Flight Vehicle.

3.3.8.1 Pre-launch Operations (U)

Pre-launch operations include receipt, check-out, assembly, maintenance, modification, and launch-verification testing of all flight hardware at the launch site. It includes certain training and bioastronautic preparation and readiness of the flight crew at the launch site. Additionally, launch site ground crew training and preparedness is contained in this system segment. Pre-launch operations also encompass the necessary planning and management required to accomplish launch, both for the pre-launch operations themselves and the support requirements thereof. Control of all launch site facilities and equipments for launch operations is contained within this segment.

3.3.8.2 Launch Operations (~~S~~-4)

Launch operation shall begin with the start of readiness count (approx R-54 hr), proceed through T-count (approx T-300 min) and terminal count (approx T-32 sec) and end at lift-off. Prior to lift-off, control of the countdown shall be exercised within the Launch Control Center

~~CONFIDENTIAL~~

3-123

~~CONFIDENTIAL~~

(LCC) in the Launch Complex. Decisions as to readiness of the test vehicle and flight crew from an equipment and health standpoint shall be made there, with readiness decisions being monitored by Mission Control at STC. From the start of countdown until the ground instrumentation systems used during ascent become primary, the LCC shall function as an arm of Mission Control. During the countdown all Flight Vehicle/Test Support interfaces with Mission Control shall be revalidated. In general, the Launch Operations System Segment shall contain the necessary on-site planning and documentation effort which will assure support of the ascent operations requirements. These ascent operations requirements include instrumentation, data handling, abort-recovery, and post-launch data needs.

3.3.8.2.1 OGE Equipment and Computer Programs (U)

Special equipment and computer programs shall be furnished to achieve an integrated MOL Flight Vehicle system exercise, countdown, and launch only to the extent required by the specified system effectiveness (paragraph 3.1.3).

3.3.8.2.2 Ground Wind Restrictions

Maximum allowable ground wind speeds for transport of the complete orbiting vehicle shall be established by the Laboratory Vehicle contractor. Ground wind restrictions for launch pad mating and other pre-launch pad operations shall be established by the launch integrating contractor.

3.3.8.3 Functional Interfaces (U)

(Functional interfaces shall be listed here when defined by the cognizant Interface Control Working Group - ICWG)

3.3.8.4 Contract End Items (U)

(The contractor shall provide for incorporation in this paragraph a list of the Contract End Items by CEI specification number, nomenclature, and the CEI into which it installs. This paragraph shall list all end items being provided under these system segments.)

In addition, the contractors shall define the range support requirements in sufficient depth to permit the extraction of those requirements as direct inputs to the appropriate range support documentation specified by SSDM 80-1.

~~CONFIDENTIAL~~

3.3.8.5

Mission Payload Launch Operations Support

(later)

3.3.8.5.1

Contractor Support

(later)

3.3.8.5.2

Software Requirements

(later)

~~CONFIDENTIAL~~

3.3.9 Flight Operations and Support System Segment (S-4)

Flight Operations and Support System Segment is concerned principally with Mission Control and includes all equipments, communications, computer programs, personnel, techniques, and procedures necessary to accomplish MOL Mission Control from start of launch countdown to mission completion, including data retrieval, laboratory disposal, and crew recovery when applicable. The segment also includes appropriate provisions for integration, simulation, training, and over-all system exercising. This segment shall be designed, implemented, tested, and operated as a system and shall have an integral system validation capability. The nominal point of segment control will be at the Air Force Satellite Test Center (STC) at Sunnyvale, California.

3.3.9.1 Mission Control Operations (C-4)

Throughout all phases, the Mission Control shall have available the worldwide facilities for range support and recovery support which have been assigned to the program. Launch range instrumentation and support will be furnished jointly by the Western Test Range (WTR) and the Satellite Control Facility (SCF). The SCF will provide the on-orbit network, Mission Control and Data Re-entry Vehicle recovery forces. Certain supplemental support will be provided by NASA (Goddard) and the National Range Division (NRD). Instrumentation ship support for injection coverage will be provided by the ship pool under the operational direction of the NRD. Communication support will be obtained from existing SCF, NRD, and NASA networks, with additional services obtained through established DOD channels. All recovery forces for the Gemini B and flight crew will be provided through the agency of the DOD Manager for Manned Space Flight Support.

3.3.9.1.1 Initial Conditions

Within the 24 hours preceding terminal countdown, the instrumentation network, recovery force system, SCF, and their supporting centers shall be checked out on an end-to-end system basis. Other supporting services, such as weather forecasting and launch range materials

~~CONFIDENTIAL~~

~~CONFIDENTIAL~~

handling services, shall be active during previous operations and shall be on-line as required. MOL vehicle/AGE/instrumentation/SCF/LCC interfaces shall have been established and validated prior to the initiation of the terminal countdown.

3.3.9.1.2      Launch Control (C-4)

Prior to lift-off, control of the countdown shall be exercised within the MOL LCC at VAFB. Decisions as to readiness of the test vehicles from an equipment standpoint shall be made there with cognizance of such readiness decisions being maintained by Mission Control. From the countdown until the instrumentation systems normally used during ascent become primary, the LCC shall function as an arm of Mission Control. During the final countdown, all Vehicle/Test Support interfaces with Mission Control shall be revalidated through the instrumentation networks and the required display/control functions activated at the STC.

3.3.9.1.3      Vehicle/Crew Control (C-4)

This function shall be physically located in the STC and shall be the prime function of Mission Control from lift-off until re-entry, crew recovery, and data retrieval. During the countdown all display and control capabilities shall be brought on-line and checked out with the data handling and instrumentation networks.

3.3.9.1.4      Network Control (C-4)

Launch area and worldwide instrumentation data handling and communications support shall be controlled during all phases by a summary status and control element at the STC. During the countdown all network control functions shall be validated and brought on-line.

3.3.9.1.5      Recovery Control (C-4)

This function shall be physically centralized at the STC and shall include the capability for deployment and control of, and continuous communication with, forces for planned, contingency, and emergency

~~CONFIDENTIAL~~



~~CONFIDENTIAL~~

recovery support. During the countdown, recovery forces shall be brought to an appropriate state of readiness.

3.3.9.1.6 Instrumentation and Communications Network (~~C~~-4)

During launch preparations local launch area instrumentation systems shall be brought on-line. Final data acquisition parameters shall be transmitted to the worldwide ground support network. All network stations shall be brought on-line and exercised on a complete system basis using, where appropriate, local simulation equipment and data tapes interconnected with the station instrumentation which shall supply data to the STC data processing and display equipment for system exercising.

3.3.9.1.7 Ascent Phase

3.3.9.1.7.1 Tracking (~~C~~-4)

The ground tracking systems shall derive position information to assist in the Mission Control functions, including discrete commanding, slow malfunction detection, and crew safety when applicable. During the later phases of ascent, both on-board guidance data and ground-derived tracking data shall be used to verify achievement of an orbit having adequate life, to establish the initial ephemeris, and to make any alternate control decisions. For the manned flights, tracking of the Gemini B spacecraft and impact prediction are required after an abort during powered flight.

3.3.9.1.7.2 Telemetry (~~C~~-4)

Telemetry data from the Launch Vehicle, Gemini B, and Laboratory shall be obtained on a selected basis from before lift-off to verification of initial orbit.

3.3.9.1.7.3 Command (~~C~~-4)

Commands to the Gemini B shall up-date displays on the manned flights. The Gemini B command format and rate will be equivalent to NASA Gemini. The WTR command system shall provide the necessary range safety commands for the Launch Vehicle.

3.3.9.1.7.4 Voice Communications (~~C~~-4)

Voice communications between Mission Control and flight crew shall be continuous.

~~CONFIDENTIAL~~

~~CONFIDENTIAL~~

3.3.9.1.7.5 Data Flow, Computation, and Display ~~(C-4)~~ (Manned Flights)  
Metric tracking data and selected Launch Vehicle and orbiting vehicle telemetry data shall be used for trajectory, IIP, flight crew safety, and related calculations. The outputs shall be displayed at Mission Control. Selected Gemini B, Laboratory, and flight crew telemetry data shall be converted to engineering units and displayed in real time at Mission Control. Launch Vehicle telemetry data shall be displayed, as well as used in computations related to slow malfunction detection. Commands shall be enabled directly from Mission Control. Mission Control shall have the capability to sense and analyze malfunctions and effect abort and switchover decisions with short time constraints. In those cases where the time constraint necessitates instantaneous decisions by the flight crew based on vehicle displays (i. e., through the on-board malfunction detection system), Mission Control shall provide assistance and backup. Special provisions shall be made to optimize retro-sequence in case of abort. A detailed assessment shall be made of the mission performance during powered flight and a baseline established for any later decisions. Necessary modifications to any planned maneuver shall be determined.

3.3.9.1.7.6 Data Flow, Computation and Display ~~(C-4)~~ (Unmanned Flights)

For unmanned flights metric data and selected telemetry data will be used for trajectory IIP and related calculations. The ground system shall comprise the applicable portions of the system utilized for manned flights, and outputs shall be displayed in real time at the Mission Control Center.

3.3.9.1.8 Early Orbit Phase

3.3.9.1.8.1 Tracking ~~(C-4)~~

At least three valid metric tracking passes shall be obtained to establish the orbit for control purposes.

3.3.9.1.8.2 Telemetry ~~(C-4)~~

For this flight phase, telemetry data shall be obtained from both the Laboratory and Gemini B.. Data from both sources shall be simultaneously selectable for retransmission to Mission Control.

~~CONFIDENTIAL~~

~~SECRET~~

3.3.9.1.8.3 Command (~~S~~-3 SAR)

Commands for the Laboratory and Gemini B shall update on-board displays, the guidance system, and other systems as required. The Mission Payload data system shall be capable of being loaded and controlled from the STC. Secure command capability shall be provided for the Laboratory Vehicle and Mission Payload Segments.

3.3.9.1.8.4 Voice Communications (~~S~~-4)

Voice Communications capability between the flight crew and Mission Control shall be continuous during all passes over primary network stations and over certain supplemental stations to minimize gaps in coverage.

3.3.9.1.8.5 Data Flow, Computation, and Display (~~S~~-4)

Tracking data shall be processed without delay at the STC computer complex until the final ephemeris is established and verified. Telemetry data will be processed in real time and displayed to the Mission Control elements.

The mission control function shall include a detailed analysis of all mission telemetry data to back up the flight crew during transfer and Laboratory activation, establish the validity of the orbit configuration, and provide malfunction detection and any remedial action. The system operations plans shall be updated or modified on the basis of the actual orbit and vehicle/flight crew condition.

3.3.9.1.9 On-Orbit Phase (~~S~~-4)

3.3.9.1.9.1 Tracking (~~S~~-4)

Tracking shall be only that necessary to provide sufficient ephemeris accuracy for control purposes. Supplemental tracking shall be called up to provide additional accuracy as required by the mission.

~~SECRET~~

~~SECRET~~

3.3.9.1.9.2 Telemetry (~~C-4~~)

During routine on-orbit operations, time-sharing of status and payload data dumps and selection and compression in real time of a limited amount of received data for transmission to the STC shall be normal modes of operation. Additional requirements derived from mission data in combinations of extra carriers or special formats on the vehicle status telemetry systems shall be processed in both on-line and off-line modes.

3.3.9.1.9.3 Command (~~S-3 SAR~~)

Commands for the Laboratory shall be the same as those for the early orbit phase with additional allowance for growth in mission information system requirements. Secure commands shall be provided.

3.3.9.1.9.4 Voice Communications (~~C-4~~) (Manned flights only)

Voice communications capability between Mission Control and the flight crew shall be continuous during all passes over primary stations. Supplemental stations shall be called up for special events or emergencies.

3.3.9.1.9.5 Data Flow, Computation, and Display (~~C-4~~)

The data handling system shall have the capability during a mission to adapt to and process different formats, information rates, and quantities of multiplexed vehicle and payload data, and to store data for trend analysis. The system shall have the capability to edit and strip-out mission data up to 1 mb/sec. Mission data in the 20 mb/sec range shall be presented to mission equipment in video form or down converted as appropriate.

During the orbit phase, Mission Control shall perform detailed analysis, failure prediction, fault location, and remedial planning as well as mission operations planning. The quality of mission data shall be evaluated in real time, or near real time, as appropriate. Detailed mission data analysis and evaluation shall function with time constraints appropriate to the mission and compatible in all cases with over all mission control function.

~~SECRET~~

~~SECRET~~

3.3.9.1.10 Re-entry Phase (Manned Flights Only)

3.3.9.1.10.1 Tracking (~~C-4~~)

Metric tracking shall be of sufficient coverage to establish the new ephemeris for the Gemini B and Laboratory after separation. Supplemental support for the Gemini B shall be expected to handle emergency as well as planned re-entry. For the primary recovery area, metric tracking shall be provided after retrofire to develop an accurate impact prediction. In case of recovery in a contingency area, metric tracking shall be utilized as available.

3.3.9.1.10.2 Telemetry (~~C-4~~)

Telemetry capability will support the Gemini B. Support shall be the maximum achievable with the primary network stations with voice coverage from additional stations.

3.3.9.1.10.3 Command (~~S-3 SAR~~)

Commands for the Gemini B will update displays, the guidance system, and other vehicle systems as required. Secure commands for the Gemini B are not required. Ground command control will provide retrofire times and sequence for both planned recovery and contingency areas.

3.3.9.1.10.4 Voice Communications (~~C-4~~)

Communications capability shall be only with the Gemini B. Relatively continuous coverage will be provided.

3.3.9.1.10.5 Data Flow, Computation, and Display (~~C-4~~)

Gemini B and Laboratory telemetry and tracking data shall be processed in real time and near real time as appropriate and displayed at Mission Control. As a result of the limited loiter time and back-up capability of the Gemini B, the mission control function shall provide extensive support for the flight crew. Close flight crew/Mission Control interaction shall be effected for the initiation of the re-entry sequence.

~~SECRET~~

3-131

~~SECRET~~

3.3.9.2 Flight Operations Support (C-4)

Flight Operations Support will be furnished for Mission Control at the STC and at remote stations of the SCF. This support encompasses interfaces with Test Support and Recovery, the mission-peculiar computer programs, the ground system simulation equipment and computer programs, and the mission operations personnel, techniques and procedures. This support also shall provide the capability for control of diverse cooperative mission support forces.

3.3.9.2.1 Satellite Test Center (S-3 SAR)

The STC shall provide the following capabilities, with the manned functions deleted for the unmanned flights:

- (a) Control and display consoles for powered flight, life support, biomedical monitoring, OV sub-systems, mission payload monitoring and control
- (b) Control and display capability for ground support and recovery control
- (c) Working areas for operations planning, analysis, control, and biomedical staffs
- (d) Mission analysis and control staff working areas
- (e) Display subsystem providing a limited number of large screen displays for special events, displays for control consoles and supporting staffs
- (f) Data buffering storage and retrieval subsystem for formatting, buffering, filing, retrieval, and outputting telemetry data
- (g) Interfaces with the launch and checkout complexes
- (h) Command storage and processing subsystem
- (i) Mission security capability
- (j) Real time computer complex for trajectory and orbit related computation
- (k) Communications switching, terminal, technical monitoring, and control facility

~~SECRET~~

~~SECRET~~

OK

The major computational and data handling functions for powered flight, orbit and recovery shall be performed by a large computer center operated as part of or in direct support of Mission Control operations.

On-line telemetry processing, buffering, filing, and display driving shall be allocated to small buffer computers located within the STC. Remote site data processing functions shall be allocated to available network station computers.

3.3.9.2.2 Operational Computer Program Support (S-4)

The Operational Computer Program support shall consist of all mission peculiar computer programs required for the entire MOL mission integrated into a compatible system (Reference SSD 61-47A). Major computer program functions required of the large computer center shall include:

- (a) Tracking data editing and conversion
- (b) Trajectory calculations
- (c) Impact prediction (including abort  $\Delta V$  and delay options for manned flights.
- (d) Coordinate conversion of telemetered booster and Gemini guidance data for manned flights.
- (e) Orbit injection (including ACTS thruster, and retro-rocket options for manned flights)
- (f) Command synthesis
- (g) Orbit determination and related computations.
- (h) Injection burn-time and vehicle altitude
- (i) Retrofire and recovery as applicable to Gemini B and Data Re-entry Vehicles.
- (j) Ephemeris-related computations
- (k) Network station acquisition tables
- (l) Mission Payload data processing
- (m) Mission Payload support -- orbit related
- (n) Telemetry and event processing and display (including post-event correlation)
- (o) Orbiting Vehicle status/malfunction monitoring
- (p) Orbiting Vehicle crew operations scheduling for manned flights.
- (q) Flight operations planning and scheduling

~~SECRET~~

3-133

~~SECRET~~

In addition a number of program components shall be provided to integrate and complete the above functions. The most significant of these is executive control, which will allow the execution of the program elements according to priorities that vary with the mission phase. Other routines required include the utility programs (compilers, assemblers, input/output routines, etc.), standard arithmetic routines (trigonometric, matrix operations, integration/differentiation, etc.), and error detection and correction programs. Major computer program functions required of the small buffer computers include:

- (a) Network station prepass information
- (b) Data acquisition
- (c) Tracking sensor data input and conditioning
- (d) Telemetry data conditioning and format conversion
- (e) Telemetry display
- (f) Telemetry alarms and checks
- (g) Telemetry data file for retrieval
- (h) Command execution and verification

3.3.9.2.3 Ground System Simulation Support (~~S~~-4)

The Ground System Simulation Support shall provide the capability to simulate all mission phases and operations and shall provide a means for training flight crews, flight directors and controllers, and support personnel located within the STC and related support areas including the network stations. In addition, the support shall provide a means of: (1) checking all operational Mission Control programs, (2) validating and accepting special MOL STC equipment, (3) training and rehearsing network station operational personnel, (4) validating communications lines to remote areas and control centers prior to a mission, and (5) finally developing and validating Mission Control and payload control procedures.

~~SECRET~~



~~SECRET~~

This support shall make use of the Mission Simulator suitably interfaced to Mission Control. Simulation modes shall include both open-loop and closed-loop with various configurations of the total network.

The modes of simulation with Mission Control shall include:

- (1) Powered flight simulation through the actual real time data handling and communications system developed for actual powered flight.
- (2) Network Station simulation through a 2400 bit per second data line and other communications in the same format as used by the actual primary network stations.
- (3) The generation of suitable simulation tapes for use by actual network stations.

3.3.9.2.4

Network Support (~~4~~) ? (~~5-3~~)?

The Network Support shall provide remote site tracking, telemetry, command, and voice functions which support on-board OV Vehicle Communications and tracking systems. Site capabilities shall include data acquisition, data handling, display, and intra/inter-site communications. The SGLS will be operational at all SCF sites for the MOL flights.

Primary SCF support locations shall include: (1) Guam; (2) Kaena Point, Hawaii; (3) Kodiak, Alaska; (4) New Boston, New Hampshire; [REDACTED] and (6) Vandenberg, California. The SCF Indian Ocean Station will support early orbit and contingencies. Each site shall be capable of verifying, in a specified time, their subsystem performance on an individual basis as well as verifying the total site configuration and ability to support the MOL mission. Validation of two-way interchange of data with Mission Control shall be possible. The extent to which the site remains fixed in the MOL support configuration depends upon the time required and confidence achieved in the checkout and verification process.

For manned flights, supplemental coverage to that of the SCF will be required during early orbits and on an emergency call-up

~~SECRET~~

~~SECRET~~

basis to improve crew safety and mission success probability. Such coverage shall be limited to UHF voice communications with the flight crew. Locations which provide coverage in early orbit and are capable of filling gaps in SCF coverage include the NASA installations at Carnarvon, Grand Canary, and Tananarive; such ETR installations as Antigua and Ascension; and the WTR installation at Midway. Present studies also consider the possibility of requesting early orbit, loiter, and special events. Metric C-band tracking data from these stations shall be routed to the STC on an off-line basis via teletype.

For either manned or unmanned flights, skin track data from SPADATS shall be made available.

3.3.9.2.4.1 Instrumentation (~~S-3 SAR~~)

The acquisition of mission data and control of the Launch Vehicle by the ground network shall be achieved by the use of C-band radar tracking supplemented by precision velocity measuring systems for determining position and velocity during powered flight, and by S-band telemetry systems for ground monitoring of system performance in real time.

The requirement for mission data and control of the OV shall be met using the integrated telemetry, tracking, command, and voice (TTCV) capabilities of the S-band Space-Ground Link Subsystem (SGLS).

The capability to simultaneously receive all SGLS telemetry, and voice information when applicable, from both the Gemini B and Laboratory shall be included at certain primary MOL network stations which are required for early orbit support; metric tracking and commanding, using SGLS, is required only of one link at any given time. Throughout the mission all primary network stations shall have the capability to select sets of data from any two PCM telemetry information carriers and to display these data locally in real time; it shall also be possible to select different sets of data or the same sets of data for transmission to Mission Control in real time.

~~SECRET~~

~~SECRET~~

All primary network stations shall provide support to the Orbiting Vehicle backup command and telemetry system.

For the manned flights only, support of the Orbiting Vehicle 20 mbs data link in the S-band (2200 - 2300 Mc RF band) shall be provided at four locations: Vandenberg AFB, New Hampshire, Alaska, and a Pacific Island site. During routine on-orbit operations, time sharing of status and payload data dumps and the selection and compression in real time of a limited amount of received data for transmission to Mission Control shall be normal modes of operation.

Voice transmission and reception in the RF band of 225-400 Mc, using AM modulation, shall be required as a minimum at all network stations for all manned flights.

Transmission of complex digital command loads from primary network stations shall be limited to quasi-real time in which commands are sent to the station prior to the pass and transmitted during the pass at the appropriate time. All primary network stations must have the capability to command and update the Gemini B systems as required for manned flight re-entry.

For manned flights, the capability must exist continuously to compute the impact point on the basis of a tracking pass after retro-fire or after receipt of voice information of the time of retrofire, attitude, re-entry profiles, and on-board instrument readings. In addition, sufficient DRV re-entry data must be provided to the SCF Recovery Control Group in time to permit location and air-snatch recovery.

3.3.9.2.4.2 Communications (S-3 SAR)

The ground communications network shall use the existing and planned NRD, STC, and in some cases for manned flights NASA networks. When applicable, sufficient channel capacity and reliability shall be provided to support flight crew-to-Mission Control voice, network stations control voice, telemetry data transmission, command control, and tracking data transmission. All launch network stations, including the injection ship and the SCF on-orbit stations, shall be netted with the STC utilizing hardline or equivalent circuits. Communications satellites may be used where appropriate.

~~SECRET~~

~~SECRET~~

The use of encrypted space-to-ground, ground-to-space communications systems for both voice and data is required; encrypted circuits from and to the STC for all SCF network stations shall be provided. For the manned flights, full duplex voice circuits from the network stations to the STC shall be employed for OV-to-ground voice relay. The capability for remote site keying of the ground-to-space transmitters from the STC shall be implemented at all SCF stations to allow direct communications between Mission Control and the flight crew. This capability is desired from all other stations utilized for voice-only transmissions where communications circuits permit, but it is not mandatory. In all cases the local station controller shall have a patch-in capability for local transmissions. Certain SCF stations shall be equipped with secure systems for flight crew voice reception and transmission utilizing SGLS and shall be equipped with secure ground communications for direct relay of classified voice information to the STC.

3.3.9.2.4.3 Data Transmission (~~C-4~~) (S-3 SAR)

*For manned flights* To achieve real time control for manned flights, telemetry and metric tracking data for the powered flight phase of the mission shall be transmitted to the STC from the launch site area and down-range ships utilizing redundant wideband data lines for real time control. For all flights, at all primary SCF network stations, secure 2400 bps data lines shall be utilized for the real time interchange of telemetry, tracking and command data with the STC. The backup mode for all data during both powered and orbital flight shall utilize teletype circuits where data lines are not achievable due to communications or equipment limitations.

3.3.9.2.4.4 Meteorological Support (~~C-4~~)

Meteorological Support shall provide weather data obtained from various reporting and forecast sources necessary to support the MOL mission.

3.3.9.3 Functional Interfaces (U)

(Functional interfaces shall be listed here when defined by the cognizant Interface Control Working Group - ICWG.)

3.3.9.4 Contract End Items (U)

The contractors shall define the range support requirements in sufficient depth to permit the extraction of those requirements as direct inputs to the appropriate range support documentation specified in chapter 3 of SSDM 80-1.

~~SECRET~~

This Page Intentionally Left Blank

~~SECRET~~

SPECIAL HANDLING

3.3.9.5 Payload Operation Control Requirements

3.3.9.5.1 Ground Support System Requirements

The major ground support system requirements for command and control of the Dorian System consist of:

a. Processing of tracking data and determination of orbit parameters. The orbit determination and ephemeris prediction shall have the following accuracy: The error in extrapolation of the position of the vehicle  $2\frac{1}{2}$  revs beyond the last set of tracking data shall not be greater ( $2\sigma$ ) than 0.2 nautical miles in track, 0.1 nautical mile cross track, and 0.1 nautical miles in altitude with respect to the reference geoid (World Geodetic System 1960). The capability to update the orbit determination and ephemeris prediction every orbit revolution shall exist in the software.

b. Processing of target list data and orbit ephemeris data to accomplish target selection. The system shall be capable of accomplishing target selection within one-half hour of receipt of a changed target list and/or new target weather information.

c. Transmission of orbit parameters and target information to the vehicle. During manned operations, predicted weather for upcoming targets also will be furnished. The capability to transmit updated orbit parameters to the vehicle within one orbit revolution of receipt of the tracking data for the orbit update shall exist, provided an SCF tracking station is available.

d. Recording and processing data transmitted from the vehicle (e.g., Data Readout System).

e. Analysis of Dorian System performance and status from data (e.g., telemetry) transmitted from the vehicle. The ground system (including personnel) shall be capable of a complete status analysis of all Dorian System components within one-half hour of transmission of telemetry data to an SCF tracking station. A capability for preliminary status analysis of major Dorian subsystems while the transmission is taking place shall also exist.

f. Computation of DRV re-entry parameters for control of DRV ejection. Pertinent data will be transmitted to the vehicle and used to control time of ejection.

SPECIAL HANDLING

~~SECRET~~

ok

~~CONFIDENTIAL~~

3. 3. 10                    Recovery System Segment ~~(C-4)~~ (Manned Flights Only)

The Recovery System Segment includes those forces deployed to support planned, contingency, and emergency recovery modes as well as pad and ascent aborts. Although Recovery Control shall be exercised as an element of Mission Control, this segment also includes those communication and control networks peculiar to the Recovery Operation.

3. 3. 10. 1                Recovery Operations ~~(C-4)~~

The recovery system shall make maximum use of those equipments, techniques, and procedures developed for Gemini/Apollo recovery support which are appropriate for MOL. The track/search operations will make use of aircraft and ship direction-finding (DF) equipment compatible with the Gemini-B HF and UHF recovery aids. A flashing light and sea marker will be used as visual search aids.

Extensive support shall be required of the world-wide communication system to handle emergency as well as planned re-entry. Relatively continuous voice coverage should be provided. In general, recovery communications shall be by a network other than the normal tracking and communications network; however, the hardwire capability of the tracking and communications network shall supplement recovery communications where applicable.

3. 3. 10. 2                Recovery Force ~~(C-4)~~

The recovery force shall be comprised of sea, land, and air units, associated crews, and specialist teams as necessary to meet the performance requirements of recovery. Such resources shall be provided from existing government sources wherever possible and practicable. Aircraft and ships shall be provided in such quantities and at such locations in the designated recovery areas or appropriate bases as is necessary to effect retrieval of the spacecraft and crew within the required access times. Special high-density recovery

~~CONFIDENTIAL~~

~~CONFIDENTIAL~~

forces shall be provided in the immediate area of the launch pad and downrange along the ground track to ensure recovery of the crew following launch phase abort. These forces shall be comprised of fixed (HC-130) and rotary wing (HH-3C) aircraft, land vehicles, amphibious vehicles, and sea craft, and shall be capable of immediate reaction in case crew abort is initiated. Recovery forces shall use both HF and UHF direction-finding equipment as the primary tracking system below the ionization blackout region and selected elements will be equipped to carry a para-rescue crew. Recovery aircraft and sea craft shall be deployed in the planned recovery areas during period of planned recovery. At other times and in other areas, recovery aircraft shall be in a location and state of readiness to support contingency and emergency areas along the ground track.

3. 3. 10. 3            Access and Retrieval (~~C-4~~)

Access time is defined as the time from determination of impact to the time when the flotation gear is rigged and first level medical assistance is provided to the crew. Access times vary during mission phases as a result of crew safety criteria and will be determined at a later date.

3. 3. 10. 4            Post Recovery (~~C-4~~)

Post recovery operations include crew medical care and debriefing and safe packaging of Mission Payload data. Data and crew shall be returned to locations to be specified.

~~CONFIDENTIAL~~



**SPECIAL HANDLING**

~~SECRET~~

3.3.10.5 Payload Recovery Requirements (~~Manned and Unmanned~~)

3.3.10.5.1 General

Photographic record will be returned by means of Data Re-entry Vehicles and in the manned version via Gemini B, as well. Recovery forces shall provide adequate security for recovered payload record until turned over to properly designated courier.

3.3.10.5.2 DRV Recovery

Data Re-entry Vehicles will be deorbited, re-enter and be air recovered in the Hawaiian area. Provision for backup water recovery will be provided.

**SPECIAL HANDLING**

3-143-142.1

~~SECRET~~

~~CONFIDENTIAL~~

3.3.11 Test Support System Segment (~~C~~-4)

The Test Support System Segment consists of all requirements (over and above those support capabilities that exist as an integral part of the SCF) for support furnished the Launch Operations System Segment, the Flight Operations and Support System Segment. In particular, this segment includes support of pre-launch, launch, ascent, and any remote station support as may be required especially for manned flights. Such support includes the planning for, acquisition of, and operation or control of the equipments, communications, computers, computer programs, personnel, techniques, and procedures necessary to support MOL operations. The segment also includes appropriate provisions for integration, simulation, training, and support exercising. Test Support shall function as an element of the total operational test system, with functional performance during each operational phase as appropriate. Pre- and post-test data are also included in this segment.

3.3.11.1 Pre-Launch Support (~~C~~-4)

Support of pre-launch operations shall begin in the form of planning for integration of all operations-support elements external to that provided by the SCF. This planning must include: any remote site telemetry, tracking, command and/or voice supplemental requirements; interstation and center ~~(s)~~ communications; extensive meteorological support; data handling and computation; and Range support for launch and ascent coverage. As operations progress towards launch, pre-launch support shall be more significantly involved in providing those services necessary to assure launch, and will include services for both flight hardware and flight crew.

3.3.11.2 Launch and Ascent Support (~~C~~-4)

In addition to providing for smooth phase-over of support services from pre-launch to launch, the employment of the resources in the launch site area shall also include all the ground instrumentation necessary for the initial powered flight phase. Ascent support down-range for all flights shall include one range instrumentation ship to achieve down-range coverage through insertion, plus approximately 30 secs.

~~CONFIDENTIAL~~

~~CONFIDENTIAL~~

For manned flights, a range instrumentation ship having precise navigation, C-band tracking, multiple link PCM telemetry, voice, real time display and computation, and high-speed data communications capabilities is required for injection coverage. From the ship, reception of selected Gemini B and Laboratory SGLS telemetry, as well as Launch Vehicle S-Band telemetry, will be required for real-time monitoring and control; the SGLS up-link capability is not mandatory. The ship shall have reliable high-speed data communications with Mission Control. Tracking of the Gemini B and impact prediction is required for an abort during powered flight.

For unmanned flights, a range instrumentation ship is required with minimum capabilities to record all telemetry links and to perform impact prediction in the event of a mission abort. This ship shall have at least reliable voice communications with the Mission Control Center.

33.11.3

On-orbit and Recovery Support (S-4)

Test Support for these phases includes the supplemental world-wide remote sites necessary to satisfy MOL Orbiting Vehicle requirements. Selected Eastern Test Range (ETR) and Western Test Range (WTR) and NASA stations shall provide support on a prearranged call-up basis for two-way DHF voice to minimize gaps in coverage. In addition, C-Band radar tracking from selected ETR, WTR, and NASA stations shall be provided, also on a prearranged call-up basis for emergency or back-up support of either the Orbiting Vehicle or Gemini B using the C-Band transponder located in the Gemini B. Metric C-Band tracking data from these stations shall be routed to the STC on an off-line basis via teletype and the STC shall be equipped to accept those metric data and perform the data conversions necessary for STC orbital calculations.

~~CONFIDENTIAL~~

~~CONFIDENTIAL~~

Any ships active in Test Support shall be on planned standby to support special events or emergencies. These ships shall be responsive to the Recovery Segment for possible supplementary support to operations requirements.

~~CONFIDENTIAL~~

3-145/146

~~CONFIDENTIAL~~

- 3. 3. 12 Flight Crew System Segment
- 3. 3. 12. 1 Allocated Performance and Design Requirements
- 3. 3. 12. 1. 1 Flight Crew Complement and Performance Allocation (S-4)

The flight crew shall perform vehicle control, monitoring, primary and back-up control of subsystems, maintenance of certain systems, mission operations, information management, certain mission control decisions, extravehicular activity, and personal maintenance together with monitoring and maintenance of crew health.

- 3. 3. 12. 1. 2 Crew Task Definition (U)

Crew Tasks shall be defined by mission requirements and evaluated by functional time line analyses.

- 3. 3. 12. 2 Peculiar Performance and Design Requirements

- 3. 3. 12. 2. 1 Flight Crew Selection and Training

- 3. 3. 12. 2. 1. 1 Flight Crew Selection (U)

The MOL SPO shall have primary responsibility and control of flight crew selection.

- 3. 3. 12. 2. 1. 2 Flight Crew Training (U)

The MOL SPO shall have primary responsibility for flight crew training. The training will consist of briefings on MOL operations, mission plans, communications, data handling, experiments, and other related technical areas. In addition, this training will cover static representation of MOL subsystems, operations or equipments, dynamic simulations of the operating situations, and combined static and dynamic simulations as described below.

- 3. 3. 12. 2. 1. 2. 1 System Function Training (U)

System training shall cover the study or demonstration of design function or operation of a single system or subsystem of a major segment of the MOL.

~~CONFIDENTIAL~~

3-147

~~CONFIDENTIAL~~

3. 3. 12. 2. 1. 2. 2 Part-Task Training (U)

Part-task trainers shall be used in training for selected function or functions of the MOL mission operation where specific critical skill(s) is required.

3. 3. 12. 2. 1. 2. 3 Procedures Training (U)

Procedures training simulates an operation of an entire segment of the MOL system, including operation under contingency conditions for the Gemini B and Laboratory System Segments. The Laboratory procedures trainer must incorporate major operational systems as warranted. The trainers needed for this purpose shall incorporate the fidelity required for realistic and meaningful simulation.

3. 3. 12. 2. 1. 2. 4 Mission Simulation (U)

Two complete mission training simulators, incorporating the procedures trainers insofar as possible, shall be developed to provide for both separate and integrated simulation of all whole mission and system segments of the MOL. This shall include interacting ground support facilities with which full mission operations can be planned, developed, validated, and rehearsed.

3. 3. 12. 2. 1. 2. 5 Environmental Training (U)

Training shall be provided in special environments involving positive acceleration (centrifuges), weightlessness (zero-g aircraft), and reduced pressures and special atmospheric compositions (space chambers).

3. 3. 12. 2. 1. 2. 6 Engineering Development Simulation (U)

Simulation of selected system elements will be provided on engineering development simulation equipment to provide early crew inputs for the design phase and to familiarize the crew with equipment and operating problems.

~~CONFIDENTIAL~~

3. 3. 12. 2. 2      Training and Proficiency Data (Deleted)

3. 3. 12. 2. 3      Man-Equipment Design Validation (Deleted)

3. 3. 12. 3      Functional Interfaces (U)

(Functional interfaces shall be listed here when defined by the cognizant Interface Control Working Group - ICWG. )

3. 3. 12. 4      Contract End Items (U)

(The contractor shall provide for incorporation in this paragraph a list of the Contract End Items by CEI specification number, nomenclature, and the CEI into which it installs. This paragraph shall list all end items being provided under these system segments. )

- 3.3.12.5 Flight Crew Dorian Support Requirements (Manned Version only)
- 3.3.12.5.1 General  
(later)
- 3.3.12.5.2 Training  
(later)
- 3.3.12.5.3 Target Acquisition and Tracking  
(later)
- 3.3.12.5.4 Film Handling  
(later)
- 3.3.12.5.5 On-orbit Optics Alignment  
(later)
- 3.3.12.5.6 Data Readout Support  
(later)



~~CONFIDENTIAL~~

#### 4.0 PERFORMANCE/DESIGN VERIFICATION AND TEST

The test operations of the developed MOL system required to fulfill the MOL mission are specified.

The tests and verification demonstrations specified herein are those required at the overall system and major system segment levels and/or the general requirements which must be recognized in preparing Part I, Section 4 of each contract end item specification. (U)

The basic document specifying the external environment to which the MOL shall be exposed is SSD Exhibit 65-7, Environmental Criteria for the MOL System.

#### 4.1 GROUND TEST REQUIREMENTS

##### 4.1.1 Development Tests

##### 4.1.1.1 General Requirements

Design development tests shall be performed to determine design feasibility, design adequacy, equipment performance, effectiveness, functional parameters, thermal and structural data, packaging and fabrication techniques, and environmental limitations. The majority of these tests shall be performed prior to design freeze; however, some tests are continued throughout the program.

##### 4.1.1.2 Over-all System Requirements

No full scale ground development tests at the Flight Vehicle system level are required. Sub scale model wind tunnel tests of the MOL Flight Vehicle shall determine aerodynamic characteristics of the combined vehicle.

##### 4.1.1.3 Orbiting Vehicle Requirements

##### 4.1.1.3.1 Antenna Tests (U)

Complete antenna patterns of all flight antenna subsystems shall be obtained using sub scale and/or full scale models.

##### 4.1.1.3.2 Compatibility Test

Tests shall be conducted on the Orbiting Vehicle System Segments to demonstrate physical, functional, and EMI compatibility.

~~CONFIDENTIAL~~

~~CONFIDENTIAL~~

4.1.1.4. Laboratory Vehicle Requirements

4.1.1.4.1 Structural Tests (U)

A static test to ultimate loads shall be performed on the primary shell structure of an assembled Laboratory Vehicle.

In addition static ultimate load tests shall be performed on all major structural assemblies not tested in the shell structure test. Ultimate load factors are given in the Laboratory Vehicle System Structural Criteria. The thermal environment shall be simulated or the loads shall be increased to account for reduced allowables under operating temperature.

The Laboratory Vehicle (or sections thereof) shall be subjected to pyrotechnic shock excitation by discharge of the pyrotechnic devices to determine the shock excitation imposed on the Laboratory Vehicle subsystems and components.

A vibration survey shall be performed on the Laboratory Vehicle with adjacent segments simulated. The dynamic properties of all significant subsystems and components not available for the test shall be simulated.

4.1.1.4.2 Leak Test

After the static test article of the above section has been tested to limit load, the load shall be removed and a leak test run. Comparison shall be made with a leak test performed before the load is applied. All sealing must be complete for the test.

4.1.1.4.3 Acoustic Test (U)

The Laboratory Vehicle (or sections thereof) shall be subjected to acoustic testing to determine the acoustic and vibration response imposed on the Laboratory Vehicle subsystems and components. Laboratory subsystem prototypes shall be installed, and if not available, mass simulated components will be used.

4.1.1.4.4 Subsystem Tests (U)

Separate subsystem development tests shall be made to verify design adequacy. Such tests shall include demonstration of on-orbit and critical ground maintenance tasks.

~~CONFIDENTIAL~~

~~CONFIDENTIAL~~

4.1.1.4.5

Attitude Control Simulations (U)

Appropriate air-bearing or servo-driven table simulations to verify the control electronic and propulsion subsystem capability shall be performed for all control modes.

4.1.1.4.6

Meteoroid and Particle Radiation Test (U)

Adequacy of the Laboratory Vehicle structure to withstand meteoroid impact shall be established by analysis based on test results simulating meteoroid impact on representative structure and on appropriate theory of meteoroid impact.

4.1.1.4.7

Atmospheric Contaminant Test (C-4)

A materials atmospheric contaminant test shall be conducted on the pressurized atmospheric environment of the Laboratory in a thermal vacuum space simulation chamber for a time period sufficient to identify contaminants and establish 30-day contaminant concentrations. Broad spectrum measurements by infrared gas chromatographic and/or mass spectrophotometric techniques will be used to determine significant toxic contaminants.

4.1.1.4.8

Space Simulation Test (U)

The Qualification Test Vehicle (laboratory module) shall be tested in a thermal vacuum space simulator to verify design adequacy of the environmental control/thermal control system and to determine the thermal characteristics of the vehicle.

The mission module Qualification Test Vehicle shall be tested in a thermal vacuum space simulator to determine the thermal characteristics of the vehicle.

For both of these tests the Qualification Test Vehicles need not have all flight equipment installed as long as all thermal characteristics are simulated.

Also, in both tests segments affecting the thermal balance shall be used or simulated to provide valid thermal interfaces.

~~CONFIDENTIAL~~

~~CONFIDENTIAL~~

4.1.1.5 Gemini B Requirements

4.1.1.5.1 General (U)

The requirements for Gemini B development testing shall be based on an analysis of the changes to the NASA Gemini configuration and equipment necessary to meet the MOL environment and mission requirements. New and significantly modified components shall be designed to Gemini B criteria and shall undergo a complete development test program. Tests shall be made to demonstrate the physical and functional compatibility, and EMI.

4.1.1.5.2 Wind Tunnel Tests (U)

Static force, moment and pressure wind tunnel tests shall be performed on the Gemini B configurations where NASA Gemini data do not exist. These tests include those cases where the external configuration or flight parameters are significantly changed or where present test data are inadequate or inaccurate.

4.1.1.5.3 Space Environmental Tests (C-4)

The effects of a prolonged period of inactivity and exposure to a 33 day space environment shall be determined by a thermal-vacuum space simulation test on the Gemini B system. Tests of individual critical components shall be performed to assess the impact of the activation following a 33-day space standby environment.

4.1.1.5.4 Structural Tests (U)

Static tests shall be performed to verify the capability of the modified and new portions of the Gemini B spacecraft to meet the requirements of the structural design criteria. Shock and vibration tests shall be performed in accordance with environmental criteria.

4.1.1.5.5 Separation Tests (U)

Staging separation tests shall be performed on the Gemini B to simulate Laboratory, retrograde, and re-entry module/adaptor separation.

4.1.1.5.6 Flight Crew Transfer Tests (U)

Tests shall be performed to demonstrate and verify the feasibility of the normal and emergency flight crew transfer between the Gemini B and the Laboratory. Transfer with inflated suit and transfer of an incapacitated flight crewman in an emergency situation shall be simulated.

~~CONFIDENTIAL~~

~~CONFIDENTIAL~~

4.1.1.5.7 Abort Tests (U)

Additional testing of the spacecraft escape system, seat ejection, system and the abort/retrograde rockets shall be accomplished as necessary.

4.1.1.6 Mission Payload Segment Requirements

Developmental simulations shall be required for all Mission Payload sub-segments. Complete development tests shall be performed to demonstrate performance, and physical and functional compatibility, including EMI.

Man-machine performance parameters shall be obtained where applicable.

4.1.1.7 Titan III Requirements

Requirements for development testing shall be determined based on an analysis of Titan III changes required for the MOL mission.

4.1.1.8 Crew Equipment Requirements

New and/or significantly modified NASA flight crew equipment shall undergo complete development testing to demonstrate capability to meet MOL environmental storage, flight crew transfer, extravehicular, and other mission requirements.

4.1.1.9 Operations Compatibility Requirements

Development testing shall be conducted to demonstrate proper operation and compatibility of the Orbiting Vehicle System, the Launch Operations, Flight Operations, Recovery, and Test Support System Segments.

4.1.1.10 Aerospace Ground Equipment Requirements

Design development testing for Orbiting Vehicle and Laboratory Vehicle AGE shall be conducted to verify the design, to determine equipment compatibility, to evaluate performance, and to develop procedures.

4.1.1.11 Orbiting Vehicle Mission Simulator Requirements (X-3 SAR)

Design development of the Orbiting Vehicle mission simulator shall be conducted to verify the design, to determine equipment

~~CONFIDENTIAL~~

~~CONFIDENTIAL~~

compatibility, to evaluate performance, and to develop procedures. Tests shall also be conducted to demonstrate proper operation and compatibility of the OV mission simulator interface with the SCF and Test Support System Segment.

4.1.2 Qualification Tests

4.1.2.1 General Requirements (U)

Qualification tests shall be performed to verify design adequacy and to demonstrate equipment performance. The test conditions shall be determined by the design requirements and consist of time and stress level factors on the anticipated environments. Qualification tests to all applicable environments shall be performed at the component and/or subsystem level. In addition thermal-vacuum and EMI qualification tests shall be performed separately on the laboratory module and mission module Qualification Test Vehicles. Qualification tests shall be completed and qualification test reports approved on all equipment prior to the flight on which the equipment is used.

4.1.2.2 Over-all System Requirements (U)

Due to the size and complexity of the Flight Vehicle and OGE Systems, there are no qualification test requirements except electromagnetic compatibility at this level of assembly. Except for electromagnetic compatibility and the qualification of the various system segments will constitute the qualification of the over-all system. The flight vehicle will be qualified for electromagnetic compatibility under conditions simulating pre-launch and launch operations

4.1.2.3 Orbiting Vehicle Requirements (U)

An electromagnetic interference (EMI) qualification test shall be performed at VAFB on the Orbiting Vehicle system as a complete system under conditions simulating pre-launch, launch, and on-orbit operations.

4.1.2.3.1 Mission Life Requirements (C-4)

Orbiting Vehicle elements and their subsystems shall be qualified for on-orbit life of 33 days.

~~CONFIDENTIAL~~

~~CONFIDENTIAL~~

4.1.2.4 Laboratory Vehicle Requirements

4.1.2.4.1 General (~~C~~-4)

The Laboratory Vehicle System segment shall be qualified both at the module level and at the component/subsystem level. These requirements shall be detailed in the Environmental specification and Test Requirements for the MOL System and the Electromagnetic Compatibility Requirements Specification (SSD Exhibit 64-4.)

In general, the components and/or subsystems will be tested to all applicable environments whereas the laboratory module and the mission module Qualification Test Vehicles shall be performed with flight crew equipment and mission equipment installed. The Laboratory module thermal vacuum tests shall be the final qualification tests of the EC/LS Subsystem, the electrical power subsystem, and the communication and data handling subsystem. In addition, the tests shall establish the capability of electro/mechanical control functions originating in the laboratory module to be properly transmitted to and executed in the mission module and the Gemini B. Segments or modules adjacent to those under test shall be simulated electrically, mechanically, and thermally as required for a valid test of each module. After subsystem and safety checks have been performed unmanned in the laboratory module thermal vacuum test, contractor personnel shall be used to represent the crew segment.

4.1.2.5 Gemini B Requirements .(U)

The Gemini B spacecraft shall be qualified to the requirements of SSD Exhibit 65-7 Environmental Criteria Specification and SSD Exhibit 64-4 Electromagnetic Compatibility requirements. Specific Gemini B components and/or subsystems which are new or modified items shall be qualified. Components and/or subsystems qualified for NASA Gemini shall not be arbitrarily requalified but the necessary testing shall be determined from previous testing and flight test history. These tests shall include, as a minimum, the sequence of operations during launch, on-orbit, shutdown and/or standby for an extended period of time and re-start and operation for re-entry.

~~CONFIDENTIAL~~

~~SECRET~~

4.1.2.6 Mission Payload Requirements ~~(S-3 SAR)~~

The Mission Payload segment shall be qualified at the sub-segment or component level using as a basis the environmental requirements specified in the SSD Exhibit 65-7 Environmental Criteria Specification and the SSD Exhibit 64-4 Electromagnetic Compatibility Requirements Specification.

4.1.2.7 Titan III Requirements (U)

The Titan III System Segment shall be qualified per the requirements of SSD Exhibit 65-7, "Environmental Criteria for the MOL System."

4.1.2.8 Flight Crew Equipment Requirements (U)

Flight crew equipment qualified for NASA Gemini shall not be arbitrarily requalified. Selective qualification requirements shall be determined on a basis of previous flight test history and contemplated usage in the MOL system environment. The flight crew equipment shall be subjected to a qualification test including the sequence of mission operations from launch, on-orbit including extravehicular activities, re-entry, and recovery.

Training equipment and simulators shall be qualified to requirements consistent with their application and interfaces with other equipment as specified in the contract end items specifications.

4.1.2.9 Launch Operations, Flight Operations, Recovery, and Test Support Equipment Requirements (U)

Formal qualification of the over-all operation of the equipment and procedures for these segments shall be demonstrated by successful completion of the functional development testing and compatibility testing. Qualification tests are required on new equipment and significantly modified equipment to demonstrate proper performance in the environment in which the equipment is normally required to function.

4.1.2.10 Aerospace Ground Equipment Requirements (U)

Most of MOL System AGE shall be qualified by acceptance test specified in paragraph 4.1.4, Acceptance and Flight Readiness Tests,

~~SECRET~~



~~SECRET~~

of this specification. Separate qualification tests are required on selected AGE items. The list of AGE items to be qualification tested shall be submitted to the MOL SPO for approval.

4.1.2.11 Mission Simulator Requirements (U)

The Orbiting Vehicle mission simulator shall be qualified as specified in Acceptance Tests and Mission Simulator Requirements of this specification.

4.1.3 Effectiveness Testing (U)

All testing performed on the MOL program is considered to be a part of the effectiveness effort. Certain tests, such as extended time tests, stress limit tests, human factors, and maintainability demonstration tests, are to be considered as basic effectiveness tests. Extended time tests consist of cycling the items to the critical environments such as vibration, thermal and vacuum, to determine the safety margin of the equipment with respect to time. Stress limit tests consist of increasing the qualification test levels until failures occur, thereby determining the margin of safety with regard to stress. Wherever practicable, effectiveness tests shall be phased in with other development or proof tests such as the qualification test program.

4.1.4 Acceptance and Flight Readiness Tests

4.1.4.1 Acceptance Test Requirements (U)

Acceptance tests shall be conducted on all contract end items and deliverable equipment. Deviations on specific items may be granted by the MOL SPO. The test conditions shall be comparable to end-use environments and severe enough to detect and eliminate discrepancies in workmanship and substandard manufacture but not so severe as to cause fatigue or wear out. A thermal-vacuum and a vibration acceptance test shall be conducted on selected components or subsystems. The ACTS/propulsion shall be static fired in lieu of an operating vibration test. A thermal-vacuum acceptance test shall be performed at the module or system segment level where applicable.

~~SECRET~~

~~SECRET~~

4.1.4.2 Flight Readiness Test Requirements (U)

Electromagnetic, electrical and mechanical compatibility tests, functional operations, and readiness tests performed at the launch site will constitute Flight Readiness Tests. Flight Readiness will be determined by these tests, plus the acceptance of the various system segments based on their acceptance tests.

4.1.4.3 Orbiting Vehicle Requirements (U)

The acceptance of the Laboratory Vehicle, Flight Crew Equipment, and Mission Payload Segments for the particular flight mission objectives, together with a Gemini B, shall be based on mechanical, electrical, electromagnetic compatibility, and functional operational tests performed after integration of these segments to form the complete Orbiting Vehicle.

4.1.4.4 Laboratory Vehicle Requirements (U)

All components and/or subsystems shall have a vibration and a thermal-vacuum test performed in accordance with the Environmental Specification and Test Requirements document. Deviations on specific items may be granted by the MOL SPO. In addition, the Laboratory module shall be subjected separately to thermal-vacuum acceptance tests.

4.1.4.5 Gemini B Requirements (U)

The Gemini B system segment shall be acceptance tested to meet MOL requirements as specified in the approved CEI specifications.

4.1.4.6 Mission Payload Segment Requirements (S-3 SAR)

The Mission Payload Segment shall be acceptance tested at the segment level. All components and/or subsystems shall have a vibration and thermal-vacuum test performed in accordance with the Environmental Criteria for the MOL System.

~~SECRET~~

~~SECRET~~

4. 1. 4. 7 Titan III Requirements (U)

The Titan IIIM System Segment shall be acceptance tested to the provisions of the applicable CEI Specification.

4. 1. 4. 8 Flight Crew Equipment Requirements (U)

The flight crew equipment shall be acceptance tested at the component and/or subsystem level. In general, the components and/or subsystems will be acceptance tested to vibration and thermal-vacuum conditions while the system flight equipment will be tested to thermal-vacuum conditions only.

Training equipment and simulators shall be acceptance tested to requirements of the contract end item specification and by complete functional operation. Compatibility with other subsystems and segments shall be demonstrated in all planned sequences and modes of operation. (U)

4. 1. 4. 9 Launch Operations, Flight Operations, Recovery, and Test Support System Segments Requirements (U)

Formal acceptance of the equipments required for these segments shall be based on the successful completion of the functional development testing and compatibility testing. Formal acceptance of individual new equipment is required and shall normally occur following installation of the equipment in its location of use and functional testing to verify specified performance has been conducted. (U)

4. 1. 4. 10 Aerospace Ground Equipment (AGE) Requirements

~~(C-4)~~

Orbiting vehicle segment AGE shall be acceptance tested at the contract end item level. Initial acceptance shall be at the manufacturer's facility and shall include a thorough physical examination to verify

~~SECRET~~

4-11

~~CONFIDENTIAL~~

conformance to the specified level of quality as well as functional tests. Further acceptance testing shall be conducted at the location of use to verify the installation and the ability of combined end items to perform their intended function. Complete mechanical and electrical compatibility (including electromagnetic interference) shall be demonstrated. Final acceptance of the AGE shall be accomplished during the pre-mission support tasks associated with the first VAFB launch of a complete OV.

4.1.4.11 Mission Simulator Requirements (U)

The mission simulator shall be acceptance tested at the contract end item level. Initial acceptance shall be at the manufacturer's facility and shall include a thorough physical examination to verify conformance to the specified level of quality as well as functional tests. Further acceptance testing shall be conducted at the location of use to verify the installation and the ability of combined items to perform their intended function. Complete mechanical and electromagnetic interference compatibility shall be demonstrated. Compatibility with other subsystems and segments shall be demonstrated in all planned sequences and modes of simulation.

4.2 MOL SYSTEM FLIGHT TEST REQUIREMENTS

4.2.1 Test Program Description (~~S-4~~)

The complete MOL System Flight Test and Evaluation consists of formal testing and evaluation including the integration of all system segments into a complete system in the final operational configuration and environment. All MOL System Flights shall be launched from VAFB with suitable instrumentation employed to determine the system functional performance, operability, and compatibility of the system segments.

4.2.2 Titan-III Development Flight Test (MOL Flight No. 1)  
(~~S-4~~)

This flight shall be unmanned and orbital. The Titan-III Launch Vehicle shall have modifications incorporated to accommodate the seven

~~CONFIDENTIAL~~

~~SECRET~~

segment solid motors, crew safety, mission success, and performance improvement changes.

The Laboratory section shall be only structurally complete. A boiler-plate Gemini shall be used for this flight. Instrumentation shall be included for temperature, acoustic, vibration, pressure, and buffet measurements. The primary objectives of this flight are to demonstrate the structural integrity of the Titan III with the MOL-type payload, collect data on the launch and Titan III, demonstrate compatibility of the MOL-type configuration with ILC concept at VAFB, and exercise selected segments of the MOL System.

4.2.3 MOL Development Flight Test (MOL Flight No. 2) (U)

This second MOL flight shall be unmanned. This flight shall be sub-orbital. The Gemini B shall employ operable subsystems, but the Laboratory Vehicle shall be only structurally complete. The Gemini B shall be separated from the Laboratory for retro, re-entry, and recovery. The primary objective of this test is to evaluate the launch, ascent, and re-entry performance of the MOL system, in relation to the requirements and operability goals, under conditions and environments closely approximating those of an actual mission. In particular, the test objectives should include: verification of the aeromechanics and launch environments of the Titan III, Laboratory Vehicle and Gemini B combination; re-entry environment and heat shield, and operational readiness of the ground and flight systems. Recovery of Gemini B shall be accomplished.

4.2.4 MOL Flight Tests (MOL Flight No. 3 and <sup>4)</sup> Subsequent)  
~~(S-3 SAR)~~

The third <sup>fourth</sup> MOL Flight shall be manned with orbital characteristics corresponding to the mission. The Laboratory Vehicle shall incorporate all subsystems for system evaluation and a Gemini B with fully operable subsystems will be used. The mission duration requirement shall be 30 days. The Gemini B shall be separated for retro, re-entry,

~~SECRET~~

4-13

~~SECRET~~

and recovery in a primary recovery area. This effort shall demonstrate the orbital capabilities of the Gemini B and Laboratory Vehicle systems and demonstrate the Launch Operations, Flight Operations, Recovery and Test Support System Segments. As a manned mission, the flight will also allow a preliminary check of the biomedical and human performance capability of the flight crew on orbit, crew transfer to the Laboratory, the operation of Laboratory Vehicle subsystems, and controlled disposal of the Laboratory Vehicle. Verification of Gemini B subsystems will be accomplished for launch, on-orbit mission operations, re-entry, and recovery. This flight is a back-up for Flight No. 2.

The fourth ~~and subsequent flights~~ shall be manned and operated for a 30-day orbital flight for operational demonstration of the MOL System in both the manned and automatic modes. ~~These flights~~ shall include the mission payload system segment required for demonstration of mission objectives.

4.2.5 MOL FLIGHT TEST (MOL FLIGHTS 5 AND SUBSEQUENT) (-3 SAR)

The fifth and subsequent flights shall be operated for a 30-day orbital flight for operational demonstration of the MOL system.

~~SECRET~~



## 5.0 PREPARATION FOR DELIVERY (U)

This section covers requirements for the preparation for delivery which are peculiar to the system (other than standard practice). Specific requirements for such non-standard practices shall be contained in appropriate Contract End Item Specifications. These shall include unusual requirements for:

- (a) Special pressure, thermal, or other environmental control required during transportation.
- (b) Peculiar hoists, handling dollies, containers, and/or protective covers.
- (c) Safety devices for ordnance/igniters.
- (d) Special methods, load, shock, etc., limitation during the handling process.

### 5.1 PACKAGING

This section covers the preservation, packing, packaging, marking and storage requirements for all items of equipment required for the MOL system. Requirements for subsystems, Gemini B, Laboratory, Orbiting Vehicle and AGE shall be included in specifications prepared by the segment contractors and approved by the MOL SPO. These specifications shall be based on methods of space packaging studies and techniques developed in connection with other manned programs, and include environmental criteria and packaging hazards peculiar to each environment. The testing programs shall insure compatibility of the packaging materials and methods with these environments.



~~CONFIDENTIAL~~

GLOSSARY

<del>AAE</del>	Aerospace Ancillary Equipment	ILC	Initial Launch Capability
ACTS	Attitude Control and Translation System	IRIG	Inter-Range Instrumentation Group
A-to-D	Analog to Digital (Conversion)	ITL	Integrate-Transfer-Launch (Facility)
AGE	Aerospace Ground Equipment	LCC	Launch Control Center
AVE	Aerospace Vehicle Equipment	MDS	Malfunction Detection System
BECO	Booster Engine Cutoff	MGE	Maintenance Ground Equipment
BOSU	Bioastronautics Operational Support Unit	MLS	MOL Launch Site
CEI	Contract End Item	MM	Mission Module
CIP	Central Information Processor	NRD	National Range Division
CPS	Central Power System	OGE	Operational Ground Equipment
CSF	Contractor Support Facility	OSAF	Office of the Secretary of the Air Force
DF	Direction-Finding Equipment	OV	Orbiting Vehicle
EC/LS	Environmental Control/Life Support	OVAB	Orbiting Vehicle Assembly Building
ECS	Environmental Control System	PBS	Program Breakdown Structure
EED	Electro-Explosive Device	RCS	Re-Entry Control System
EET	Event Elapsed Time	REM	Re-Entry Module
EKG	Electrocardiogram	SCD	Specification Control Drawings
EMI	Electromagnetic Interference	SCF	Satellite Control Facility
EVA	Extravehicular Activity	SGLS	Space-Ground Link Subsystem
FAA	Federal Aviation Agency	SRM	Solid Rocket Motor
GSE	Ground Support Equipment	STC	Satellite Test Center
ICD	Interface Control Drawing	T-Count	Terminal Count
ICWG	Interface Control Working Group	TTC	Tracking, Telemetry, and Command
IDEP	Inter-Service Data Exchange Program	TTCV	Tracking, Telemetry, Command, and Voice
IFS	Interface Specification	VET	Vehicle Elapsed Time
IGS	Inertial Guidance System	VOX	Voice
IIP	Instantaneous Impact Point		

~~CONFIDENTIAL~~