

~~SECRET~~ SPECIAL HANDLING

DIN 3780-182-5
PAGE 1 of 20
COPY 7 of 8

PIR _____

DATE: May 20, 1968

TO: J. Frey

FROM: W. Montgomery

LIMITED SEARCH MODE CAPABILITIES OF THE ATS

The present SPDR specifies the ATS shall have limited search capability. Discussions with the customer have led to the interpretation of this as, "the capability which enables the operator to scan the earth with the system, while controlling the scan rate or position with the manual control stick".

There seems to exist the belief that the search rates and accuracies which can be controlled by the operator can be just about anything that he desires. At the present time there are no time or accuracy requirements in the SPDR to define performance of the system in this mode of operation. This PIR defines the search mode performance in terms of the capability of the operator and ATS system to:

1. Change the LOS rate with a specified accuracy within a specified time.
2. Reposition the image in the field of view with a specified accuracy and within a specified time.

The limited search mode performance shall be defined as:

The capability to make the LOS rate change 1000 u radians per second with an accuracy of ± 17 u radians per second within 2.5 seconds after the operator initiates the change via the control stick.

The capability to reposition the image from the edge of the field of view to the center of the field of view ± 2 min within 2.5 seconds after the operator initiates the command via the control stick. The magnification shall be in the high range (63 1/2 to 127x).

To reposition the image to the center of the field of view and to reduce the rate error after the repositioning maneuver to less than ± 17 radians will require at least four seconds.

Simulations have been run for the various stick configurations and assumed man models and the results are discussed in the PIR; however, it should be emphasized that these are only assumed man models. With this in mind, it is felt the times given for changing rate, repositioning and repositioning and rate nulling are the shortest that GE should agree to accept as SPDR requirements for limited search operation, until more work is done with the crewmen and the simulator to tie down the man's transfer function.

JUN 24 1968

~~SECRET~~ SPECIAL HANDLING

50354-14-1

1200 94

~~SECRET~~ SPECIAL HANDLING

DISCUSSION

The system capabilities given are a function of the operator's capabilities and are based on an assumed operator model. The system's search capability is presently limited by the operator's capabilities and the computer sampling rates and not by the scanner hardware. The scanner torquers and control loops are sized to operate in the slew mode and thus are capable of high search rates. A 17400 u-radian per second step command can be input to the scanner and the rate will be changed by this amount ± 17 u radians per second in > 0.5 seconds without the man in the loop.

The variables which affect the limited search mode performance are:

1. Man's transfer function
2. Control Stick transfer function
3. Computer Sampling Rate
4. Scanner Drive Servo Configuration

Variable (1) is not known at this time, thus in attempting to determine the time required to change the rate or position of the ATS it is necessary to assume a man model. Based on information given in Krendel and McMer the following transfer functions were used in simulating the limited search problem.

A.
$$\frac{K e^{-AS}}{(s/10+1)(s/100+1)} \quad A \rightarrow 0.015 \text{ to } 0.15 \text{ sec}$$

B.
$$\frac{K (s/5+1) e^{-AS}}{s (s/10+1)(s/100+1)} \quad A \rightarrow 0.015 \text{ to } 0.15 \text{ sec}$$

C.
$$\frac{K (s/0.5+1) e^{-AS}}{s (s/10+1)(s/100+1)} \quad A \rightarrow 0.015 \text{ to } 0.15 \text{ sec}$$

Transfer function (A) was the basic transfer function used.

Transfer function (B) was used to determine the difference in system performance when the integral plus proportional characteristics were removed from the control stick and incorporated in the man.

Transfer function (C) was the basic man model modified to enable him to make the repositioning maneuver using an integral plus proportional control stick. It can be seen that the required increase in the man's capabilities (change in transfer function) precludes the use of an integral plus proportional stick for repositioning.

~~SECRET~~ SPECIAL HANDLING

~~SECRET~~ SPECIAL HANDLING

4/6?

The control stick transfer function can be varied by changing constants in the digital computer. The only constraint on the control stick was that only 433 quantum levels were available at maximum stick deflection. This constraint requires that a gain change be incorporated in the computer when the ratio of the maximum stick output, to resolution per quantum level requirement exceeds 433. Control stick transfer functions used were:

1. Proportional = K
2. Integral plus proportional = $\frac{(s/5+1)}{s} K'$

The computer sampling rate was fixed at ten times per second. The initial sample time was varied relative to the start of the settling problem in the simulation.

The Scanner Drive Servo Configuration was the baseline servo with the 30 radians per second break in the D/A buffer removed. It was felt that the effect of this break on the simulation results would be minimal in that the phase margin of the man loop would be decreased slightly but the ten cps effects of the sampler would also be decreased. The net result would be little change in the time required to settle a specified accuracy.

RATE CHANGE CAPABILITIES

1. Proportional plus Integral Control Stick

The rate change problem was simulated on the digital computer with the control stick in the proportional plus integral configuration.

The servo characteristics were:

Operator = $\frac{0.4 e^{-As}}{(s/10+1)(s/100+1)}$ $A \rightarrow 0.015 \text{ to } 0.15$

Stick Scale Factor = one u radian per second quantum, maximum output
At D/A Converter 433 u radians per second.

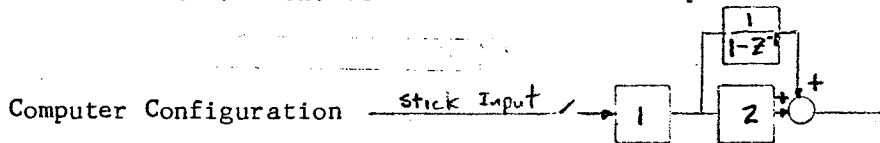

Scanner Servo =
Closed Loop Frequency Response

$$\frac{(s/35+1)(s/100+1)}{(s/54+1)(s/660+1)(s/945+1)(s^2/(128)^2 + 2\frac{(0.56)}{128}s + 1)}$$

Figure (1) shows the servo diagram of the simulation.

This configuration was simulated with the operator's delay varied from 0.015 to 0.15 seconds. The results indicate that the settling time to a rate change increases as the operators delay increases. The time of the first sample relative to the start of the rate change by the operator was also varied. The

~~SECRET~~ SPECIAL HANDLING

~~SECRET~~ SPECIAL HANDLING

results indicate that the settling time is increased slightly as the time of the first sample is increased relative to the start of the problem.

Figure (2) shows the sampling profile for the computer output when the operator's delay is equal to 0.15 seconds and the initial sample occurs 0.05 and 0.10 seconds respectively after the rate change starts.

Figures (3) and (4) show the final settling profiles for the two initial sample times.

The simulation results indicate that with this stick configuration and the assumed operator characteristics, the "worst case" settling time = 1.95 seconds. Recent information from Aerospace indicates the man's delay may be greater than 0.20 seconds. On this basis, an acceptable SPDR time requirement to change the LOS rate 1000 ± 17 u radians per seconds using this stick configuration would be 2.5 seconds.

2. Proportional Stick

A simulation was run with a proportional control stick. The integration accomplished by proportional and integral control stick of the previous simulation was now assumed to be done by the operator, thus the $(s/5+1)/S$ characteristic of the proportional stick was incorporated into the man mode.

First simulation results indicated that for the same man stick gain, the overshoot and setting time were increased when compared to the simulation with the proportional and integral stick configuration. This was a result of the increased phase shift (90 degrees) in the control loop due to the integration being made continuously in the man model. When the integration was made in the computer as was the case for the proportional and integral stick simulation, the phase resulting from this operation was somewhat less than (90 degrees). It can be shown that the phase shift resulting from digital integration is a function of the loop crossover frequency W_n and the sampling frequency W_s . For $W_n < W_s$, the phase is less than 90 degrees. To optimize the loop response, the man-stick gain was decreased from 4 to 2.5. This is justified since the man will adapt and decrease his gain when faced with the same conditions (decreased damping).

The servo characteristics of the simulation were changed to:

$$\text{Operator} = \frac{0.25 (s/5+1) e^{-AS}}{s(s/10+1)(s/100+1)} \quad A \rightarrow 0.015 \text{ to } 0.15$$

Stick Scale Factor 3 u radians per second quantum
At D/A Converter maximum out 433 quanta

Computer Configuration Stick Input $\text{---} \boxed{3} \text{---}$ Loop Command

$$\text{Scanner Servo Closed Loop Frequency Response} = \frac{(s/35+1)(s/100+1)}{(s/54+1)(s/660+1)(s/945+1) \left((s/128)^2 + \frac{2(0.5)}{128} + 1 \right)}$$

~~SECRET~~ SPECIAL HANDLING

~~SECRET~~ SPECIAL HANDLING

Figure (5) shows the servo configuration for this simulation.

With the reduced stick gain (2.5 versus 4.0), the simulation was rerun and the operator's delay varied from 0.015 seconds to 0.15 seconds. The results again indicated that settling time was directly proportional to the operator's delay. The results showed that the time of the first sample relative to the start of the rate change was not critical. Figures 6, 7, and 8 show the sampler profiles and the final settling profiles. With the operators delay set equal to 0.15 seconds, the worst case settling time was equal to 1.6 seconds. This is somewhat better than with the time determined for the proportional and integral stick simulation; however, it should be noted here that the man was assumed to be able to do the integration operation in this simulation. If the man-stick gain had been lowered slightly for proportional and integral stick simulation, the settling times would have been approximately equal and the two stick configurations would appear to allow the same transient performance. The integral plus proportional stick allows for better stick resolution (one u radian per second) that does the proportional stick (three u radians per second). The integration operation in the computer rather than in the man allows this improvement.

3. Proportional and End Stop Stick

Recent simulation results indicate that the crewmen prefer this stick configuration. A simulation is being run presently to determine effects of this configuration with respect to the limited search capabilities of the ATS.

Assuming the same man model as for the proportional stick simulation, the worst settling time for Proportional and End Stop could be determined

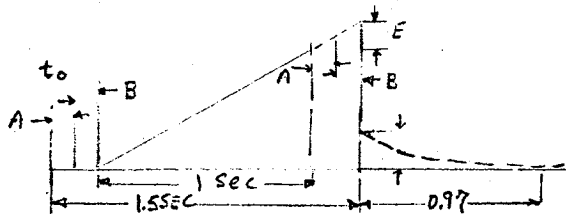

A = 0.15 sec = Man's Delay
 B = 0.1 sec = Computer Delay
 E = Error Due to Delays
 = 225 u rad/sec

by letting the stick have the following scale factor.

1 u rad/sec for inputs \leq 300 u rad/sec
 300 (1+2/5 u rad/sec) for input $>$ 300 u radians

For these stick gains and worst case delays of 0.15 for the man and 0.1 seconds for the computer total settling time will be:

Time	=	0.15	initial man delay
		0.10	computer delay
		1.00	time to reach 900 u rad/sec
		0.15	man delay in removing end stop input
		0.10	computer delay in removing end stop input
		0.97	time to settle from 225 u rad/sec to 17 u rad/sec with proportional stick
		2.47	seconds

~~SECRET~~ SPECIAL HANDLING

This is a worst case analysis and training of the man will help him to determine the optimum time to remove the end stop input. After training, this stick configuration will probably allow the rate change to be made in approximately two seconds assuming the man's delay does not exceed 0.15 seconds.

REPOSITIONING CAPABILITY

1: Proportional plus Integral Control Stick

A simulation was run to determine the repositioning capabilities of the ATS using a proportional plus integral control stick. With the man as a position sensor, it becomes necessary to incorporate a low frequency lead into the man model to keep the man-loop stable when an integral plus proportional stick is used. Figure (9) shows simulation servo configuration. When this lead is put into the man model it means the man's capabilities are greatly increased and are not realistic. This can be seen in figure (10) which shows the sampler profile. The lead in the man means he reacts almost instantaneously and displaces the control stick by a very large amount. If the man could have the transfer function needed, it would be undesirable to use the proportional and integral stick in the repositioning problem due to the large stick range which would be necessary and due to large variation in settling time as a function of the time of the first sample. This also can be seen in figure (10).

The stick configuration would not be used if the image were to be repositioned.

2. Proportional Stick

The repositioning problem was simulated using a proportional stick and the basic transfer function of the man given in Krendel and McMuer.

The servo characteristics used in this simulation were:

Man = $\frac{0.25 e^{-AS}}{(s/10+1)(s/100+1)}$ A \rightarrow 0.015 to 0.150 Sec

Stick Scale Factor 40 u rad/sec/quantum

At D/A Converter

Computer Configuration Stick Output \rightarrow 40 \leftarrow Loop Command

Scanner Servo Closed Loop = $\frac{(s/35+1)(s/120+1)}{(s/54+1)(s/60+1)(s/995+1)(s/123+2\frac{2(0.55)}{123}+1)}$
Frequency Response

The image was repositioned within the two are minutes tolerance in less than two seconds assuming the man's delay to be 0.15 seconds. Should the delay be longer, then the settling time will be longer.

~~SECRET~~ SPECIAL HANDLING

~~SECRET~~ SPECIAL HANDLING

To make the repositioning maneuver, the control stick scaling must be 40 μ radians per quantum to insure that there is sufficient stick range. If at the conclusion of the repositioning it is desirable to reduce the rate error, it will be necessary to change the stick scaling via a constant in the computer. This will induce a transient and will increase the time necessary to reduce the rate error. The rate error is large when the position error is within the two μ tolerance, hence to reposition and reduce rate error to less than $\pm 17 \mu$ radians per second requires considerable more time. The servo configuration of the simulation is shown in figure (11).

The rate and position errors are shown in figure (12).

~~SECRET~~ SPECIAL HANDLING

~~SECRET~~ SPECIAL HANDLING

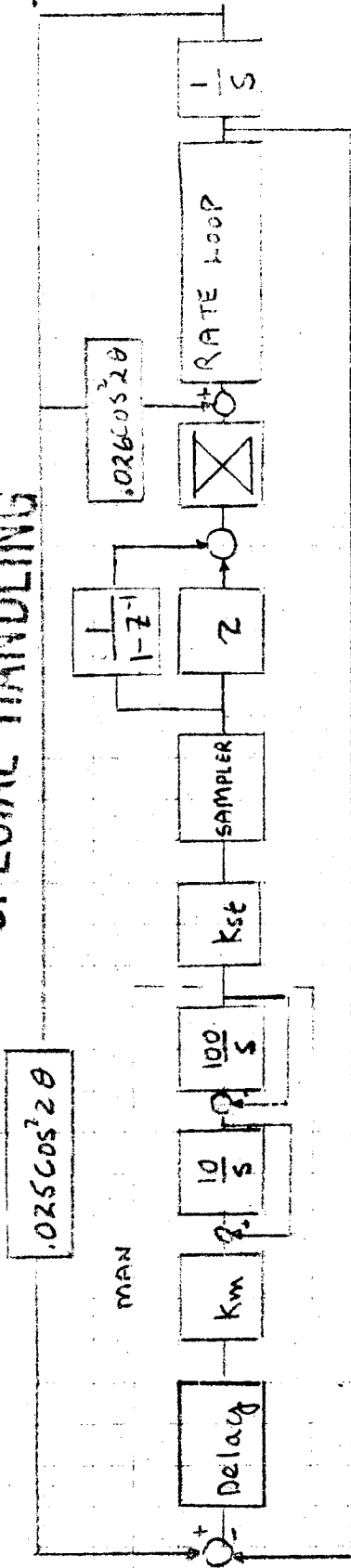

Delay \rightarrow 0.015 to 0.15

K_m = MAN GAIN

K_{ST} = Stick Scale Factor

Σ = Extrapolator $t = 0.015$ sec

Servo Configuration. Rate Change Simulation
with Integral + Proportional stick.

Figure (1)

~~SECRET~~

STEERING GUIDANCE

INTEGRAL PROPORTIONAL SAMPLED OUTPUT
TO DRIVE LOOP

t₀ 0.1 0.2 0.3 0.4 0.5 0.6 0.7 0.8 0.9 1.0 1.1 1.2 1.3 1.4 1.5 1.6 1.7 1.8 1.9 2.0

A = _____ MAN DELAY = 0.15 Sec
B = _____ COMPUTER DELAY = 0.05 Sec
C = _____ COMPUTER DELAY = 0.10 Sec

CASES # 1 & 2

SAMPLED OUTPUT CASE 1

SAMPLED OUTPUT CASE 2

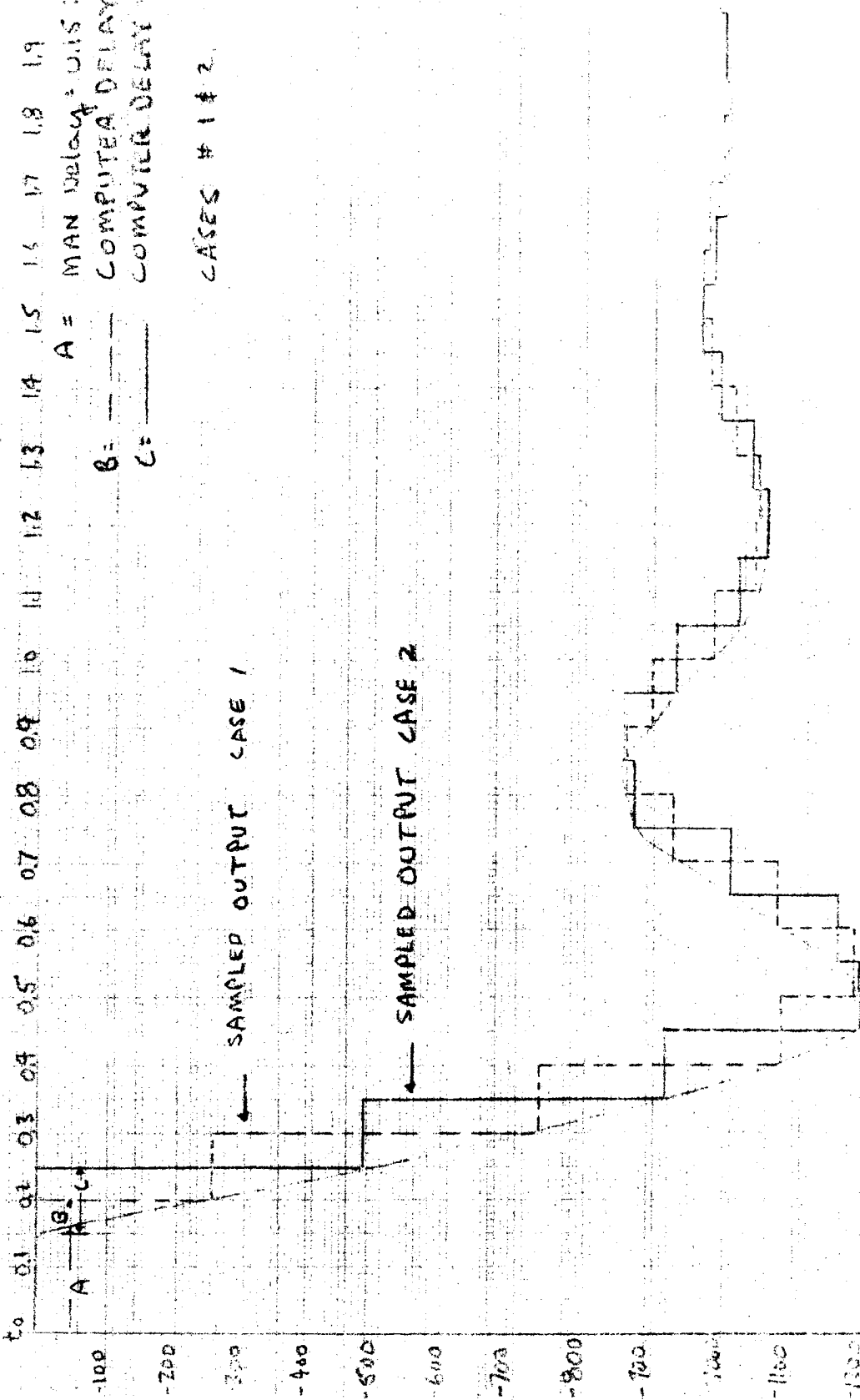
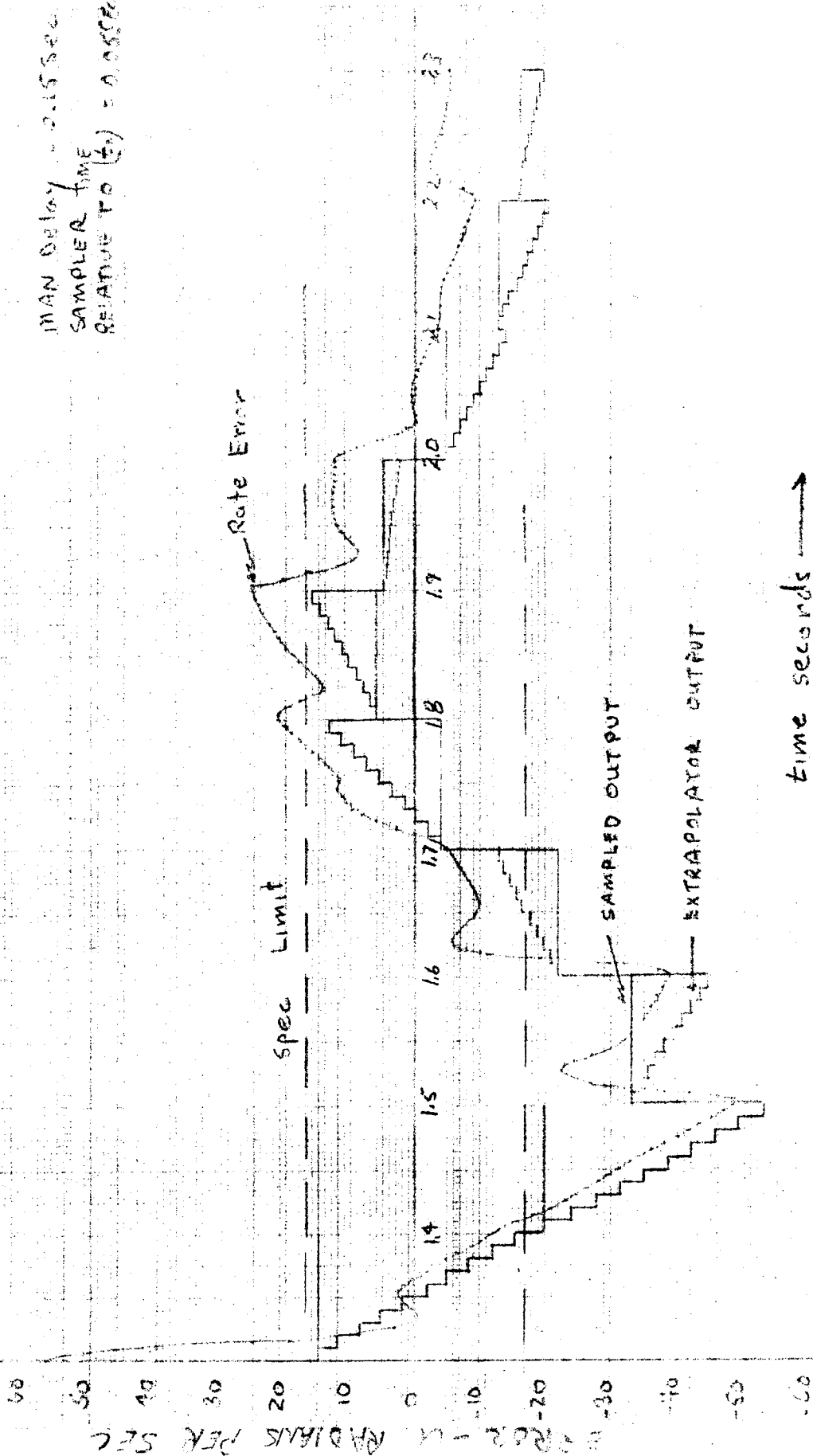

Figure (2)

~~SECRET~~ STEERING GUIDANCE

~~SECRET~~ SPECIAL HANDLING
TELETYPE + PROPORTIONAL STICK
FINAL SETTLING PROFILE
CASE 2

MAN DELAY = 0.15 sec
SAMPLER TIME
RELATIVE TO (1/2) = 0.05 sec



time seconds →

Figure (3)

~~SECRET~~ SPECIAL HANDLING

~~SECRET~~ SPECIAL HANDLING
INTERGRAL PROPORTIONAL STICK
FINAL SETTLING PROFILE
CASE #2

MAN'S Delay = 0.15Sec
SAMPLE TIME
Relative To (to) = 0.15Sec

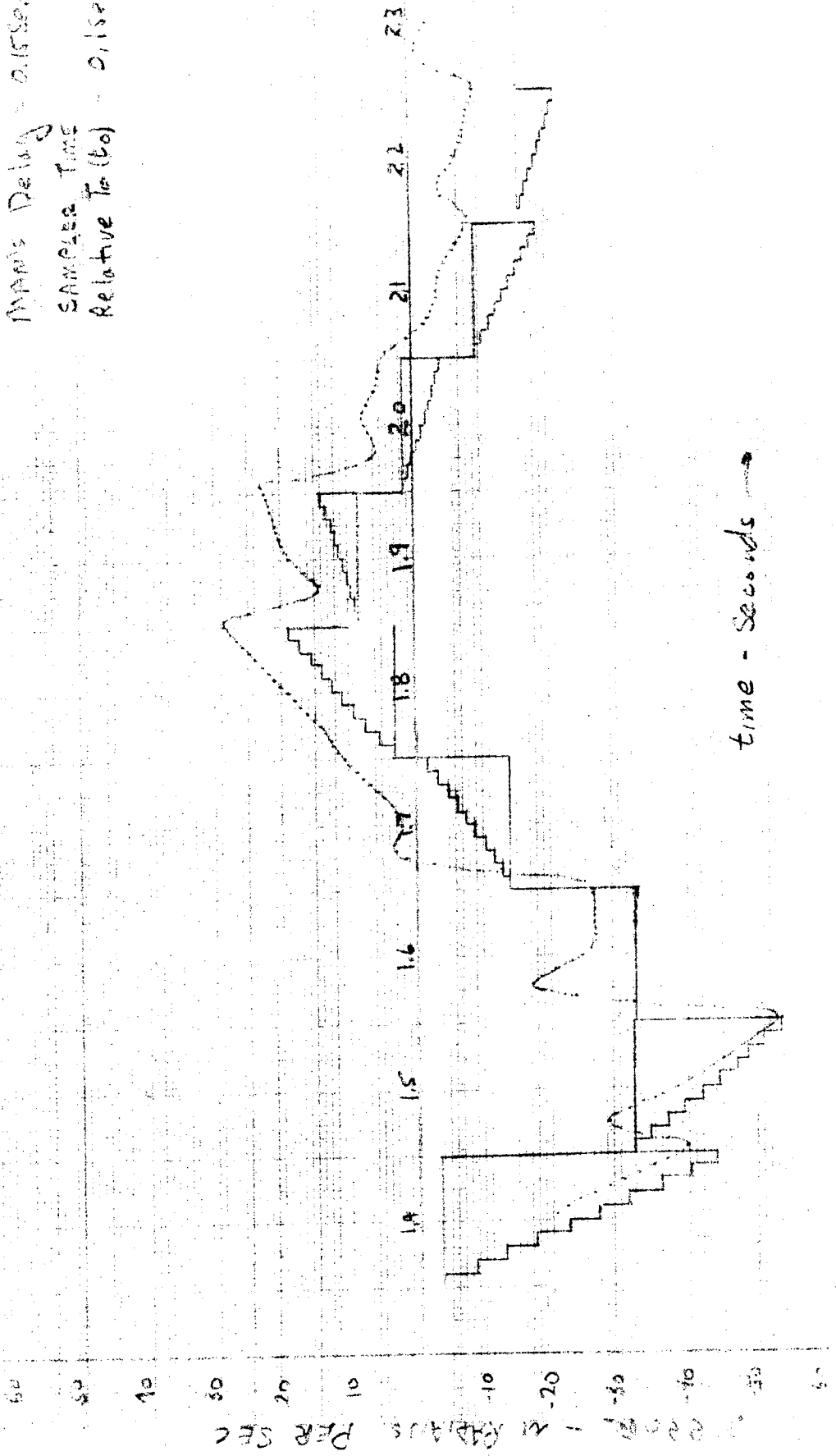

~~SECRET~~ Figure (4) HANDLING

~~SECRET~~ SPECIAL HANDLING

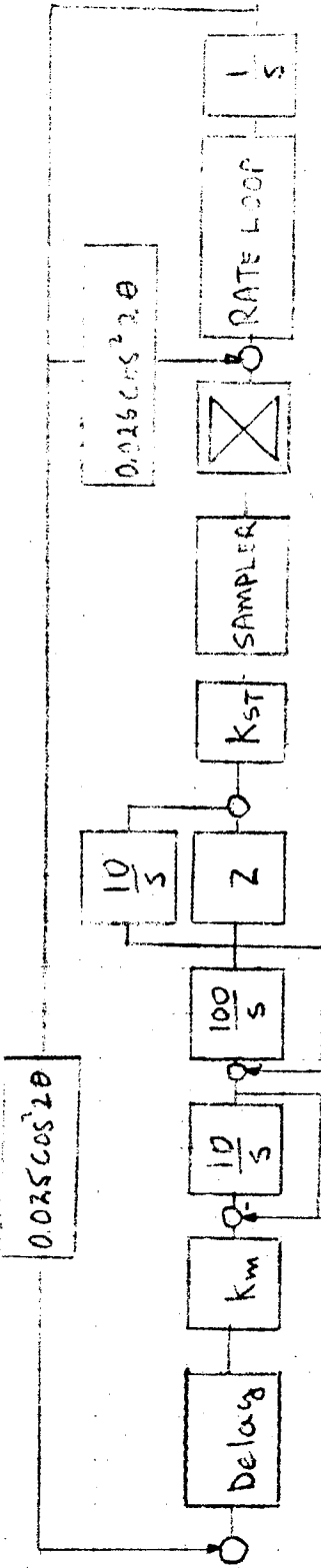

Delay: 0.015 → 0.115

$K_m = \text{MAN GAIN}$

$K_{st} = \text{STICK SCALE FACTOR}$

X Extrapolator 0.01 sec

Servo Configuration Rate Change Simulation
with Proportional Sticks

Figure 2
~~SECRET~~ SPECIAL HANDLING

~~SECRET~~ SPECIAL HANDLING

PROPORTIONAL SAMPLED PROFILE
TO DRIVE LOOP

0 01 02 03 04 05 06 07 08 09 10 11 12 13 14 15 16 17 18 19 20
A $\frac{B}{C}$ A = MAN'S Delay = 0.15 Sec
time seconds \rightarrow

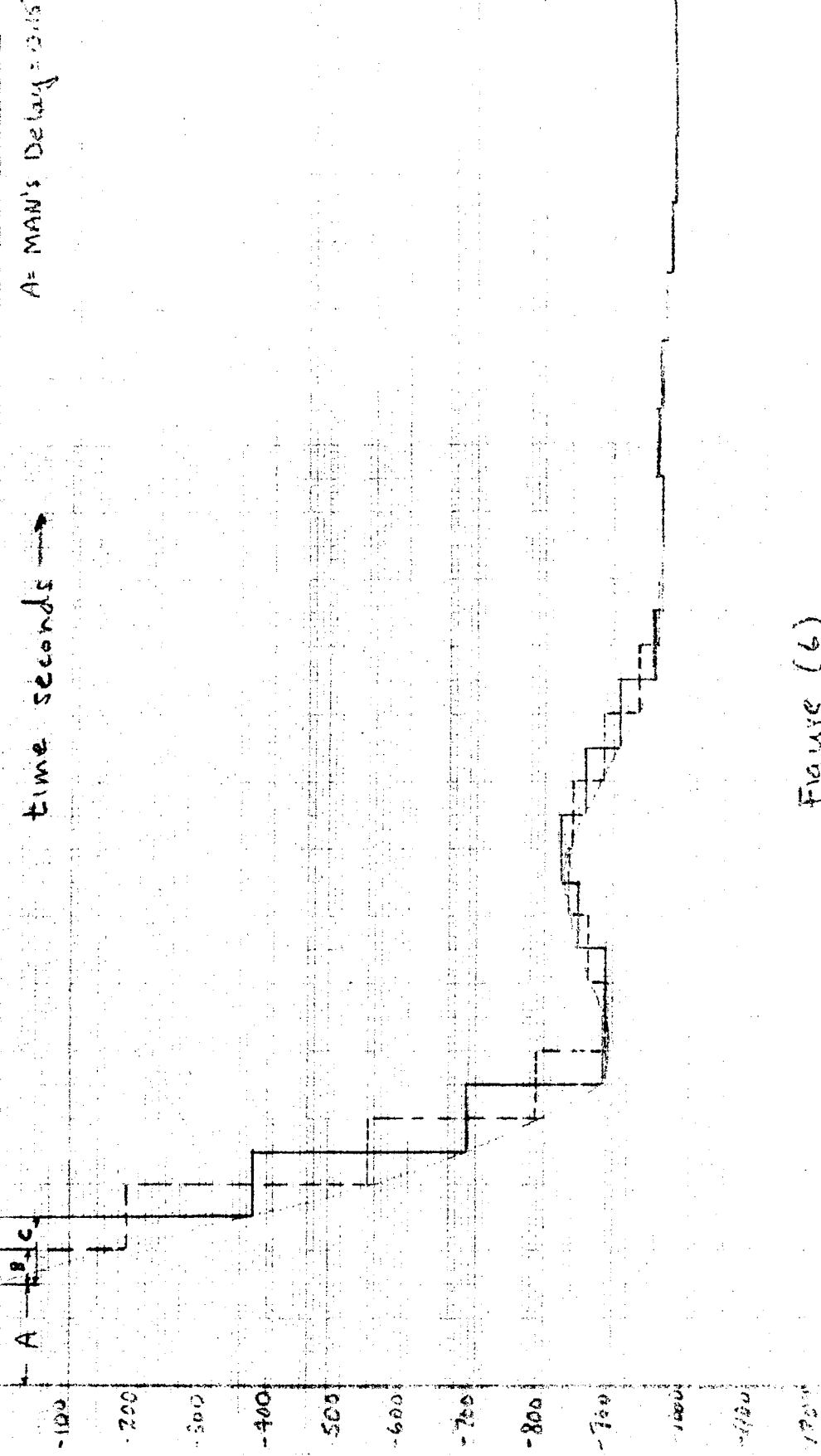

Figure (6)

~~SECRET~~ SPECIAL HANDLING

~~SECRET~~ SPECIAL HANDLING

PROPORTIONAL STICK
FINAL SETTLING PROFILE

CASE # 1

MAN'S Delay = 0.15 Sec
Sampler Time
Relative To (b) = 0.1 Sec

41
ERROR IN Radians PER SEC
50
40
30
20
10
0
-10
-20
-30
-40
-50

1.2 1.3 1.4 1.5 1.6 1.7 1.8 1.9 2.0 2.1

SPEC LIMIT

time - Seconds →

Figure (7)

~~SECRET~~ SPECIAL HANDLING

~~SECRET~~ SPECIAL HANDLING

PROPORTIONAL STICK

FINAL SETTLING PROFILE

MIN'S DELAY 0.155sec

Sample Time

Relative to (6) 0.055sec

-51-
INFRARED Radiation PER DEG
50
40
30
20
10
0
-10
-20
-30
-40
-50

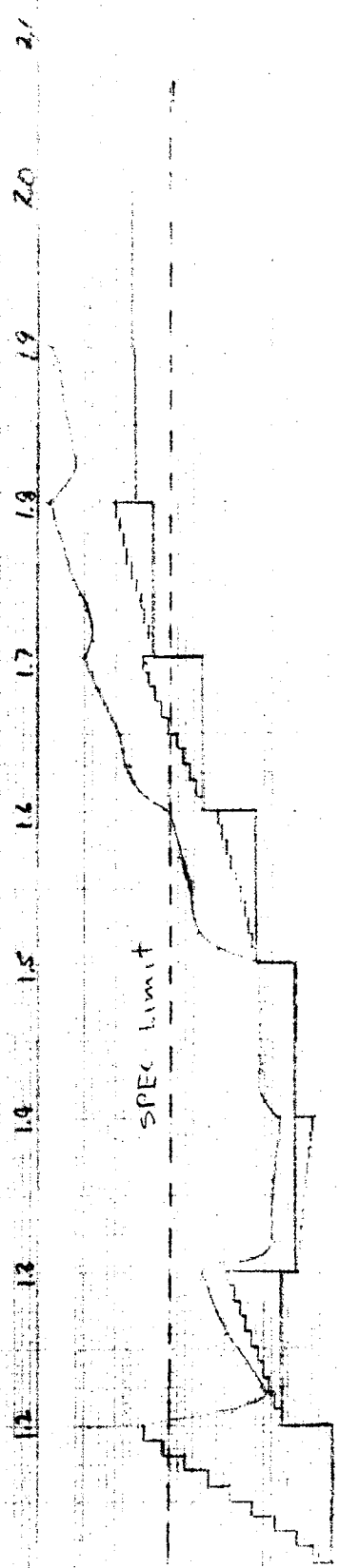

time seconds →

Figure (8)

~~SECRET~~ SPECIAL HANDLING

~~SECRET~~ SPECIAL HANDLING

I.C. = 0.00667 493 493

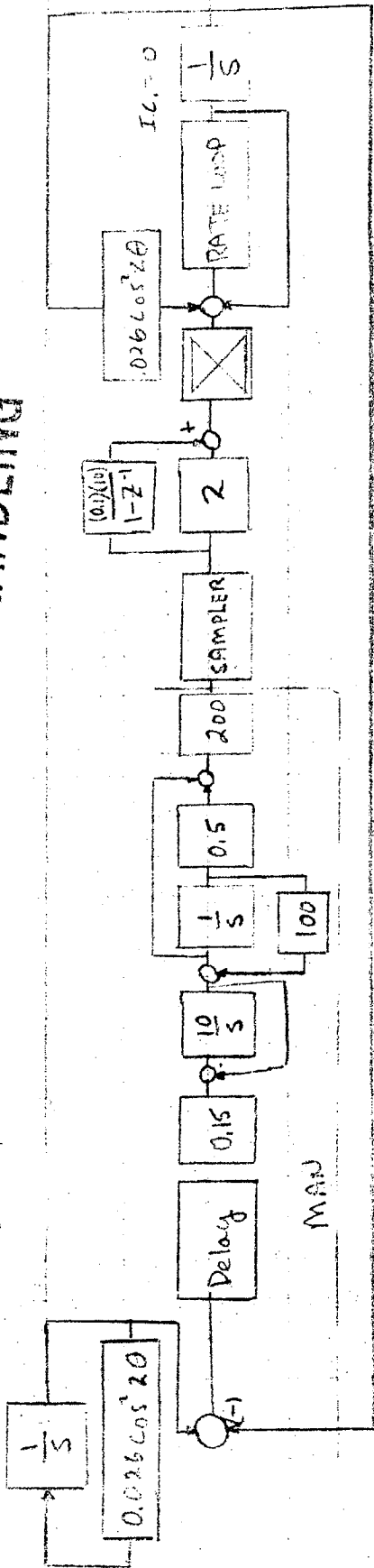

Delay \rightarrow 0.015 to 0.15 sec

Σ = Extrapolator $t = 0.01$ sec

1/6

Servo Configuration Repositioning Simulation
with Integral + Proportion Stick

Figure (1)

~~SECRET~~ SPECIAL HANDLING

~~SECRET~~ OF SIGNAL HANDLING

SAMPLER PROFILE

Repositioning with
Integral & Proportional Stick

Signal sampled = (2x stick output at time of first sample)

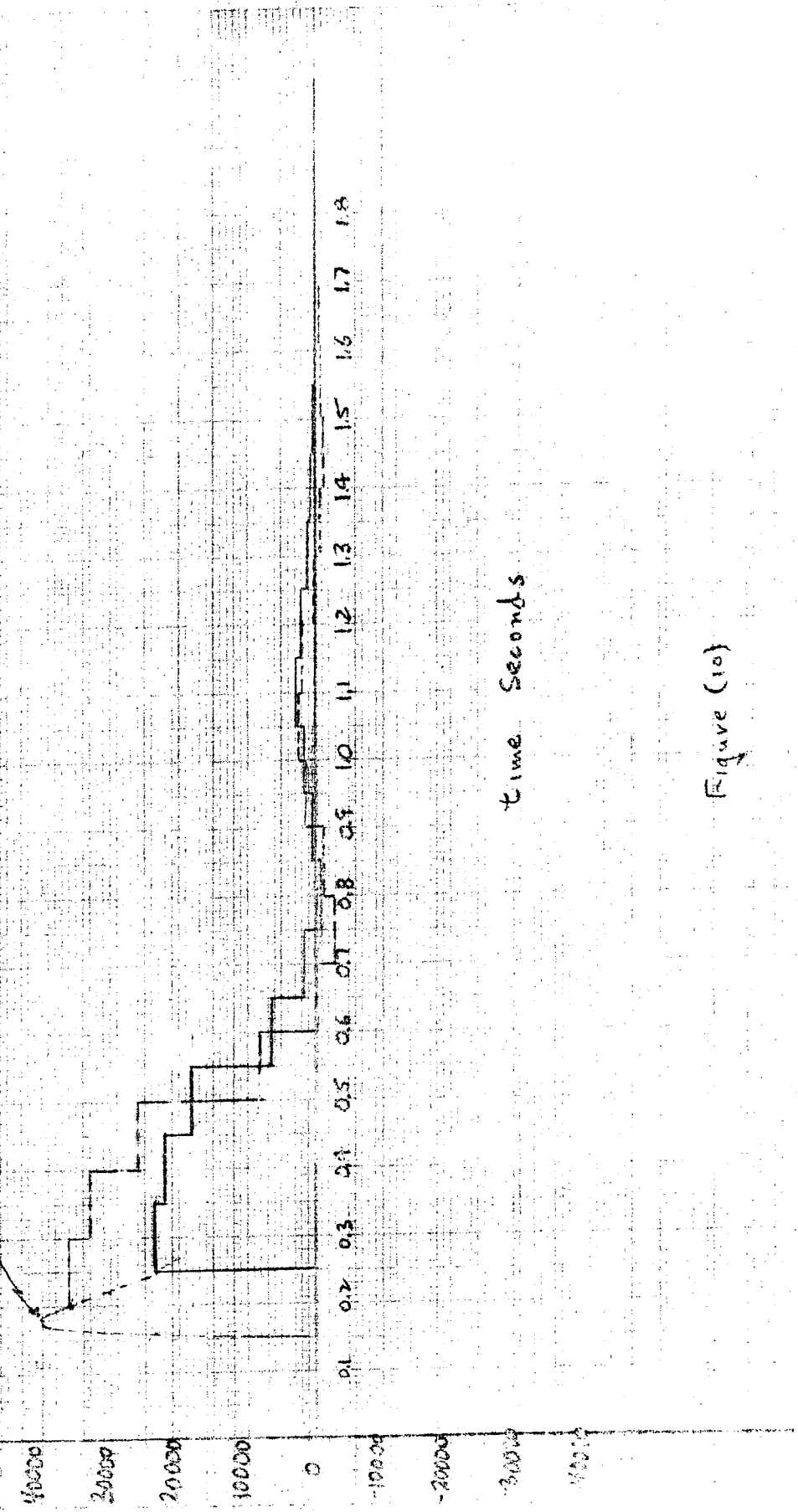

Time Seconds

Figure (10)

~~SECRET~~ OF SIGNAL HANDLING

~~SECRET~~ SPECIAL HANDLING

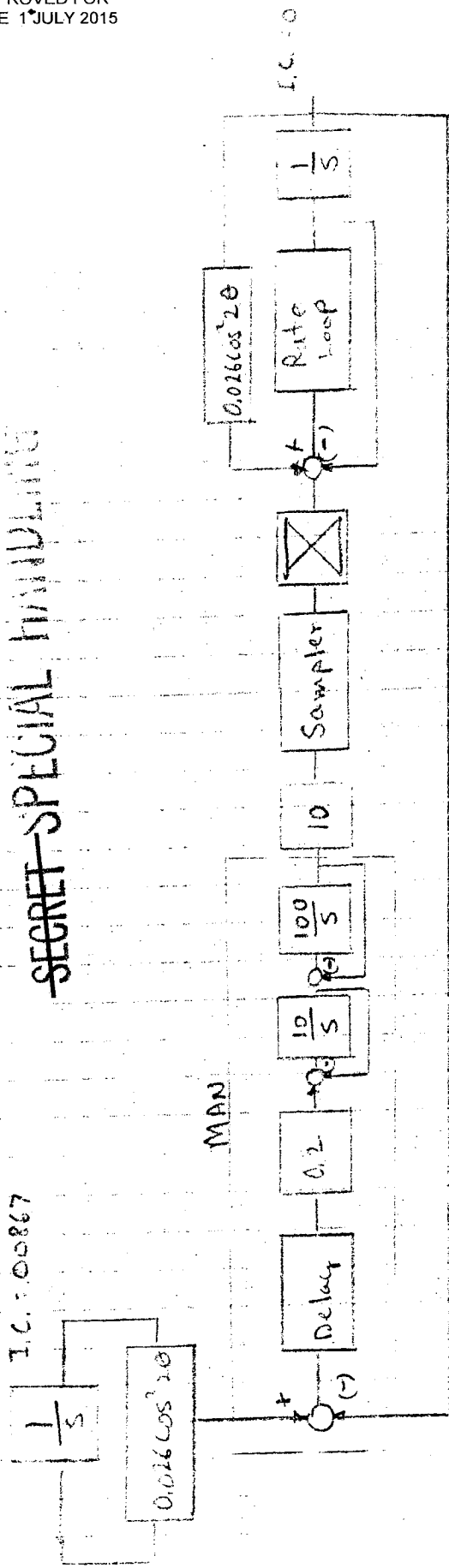

1/10

Delay \rightarrow 0.015 to 0.15
 Σ = Extrapolator $t = 0.015 \text{ sec}$

Servo Configuration Repositioning Simulation
 with Proportional Stick

Figure (ii)

~~SECRET~~ SPECIAL HANDLING

~~SECRET~~ SPECIAL HANDLING

Final Setting Profile
 Repetition with Proportional Step

MAN'S DELAY 0.155 sec
 SAMPLER TIME
 Relative to $t_0 = 0.155$ sec

0.0704 RADIANS
 STEP INPUT

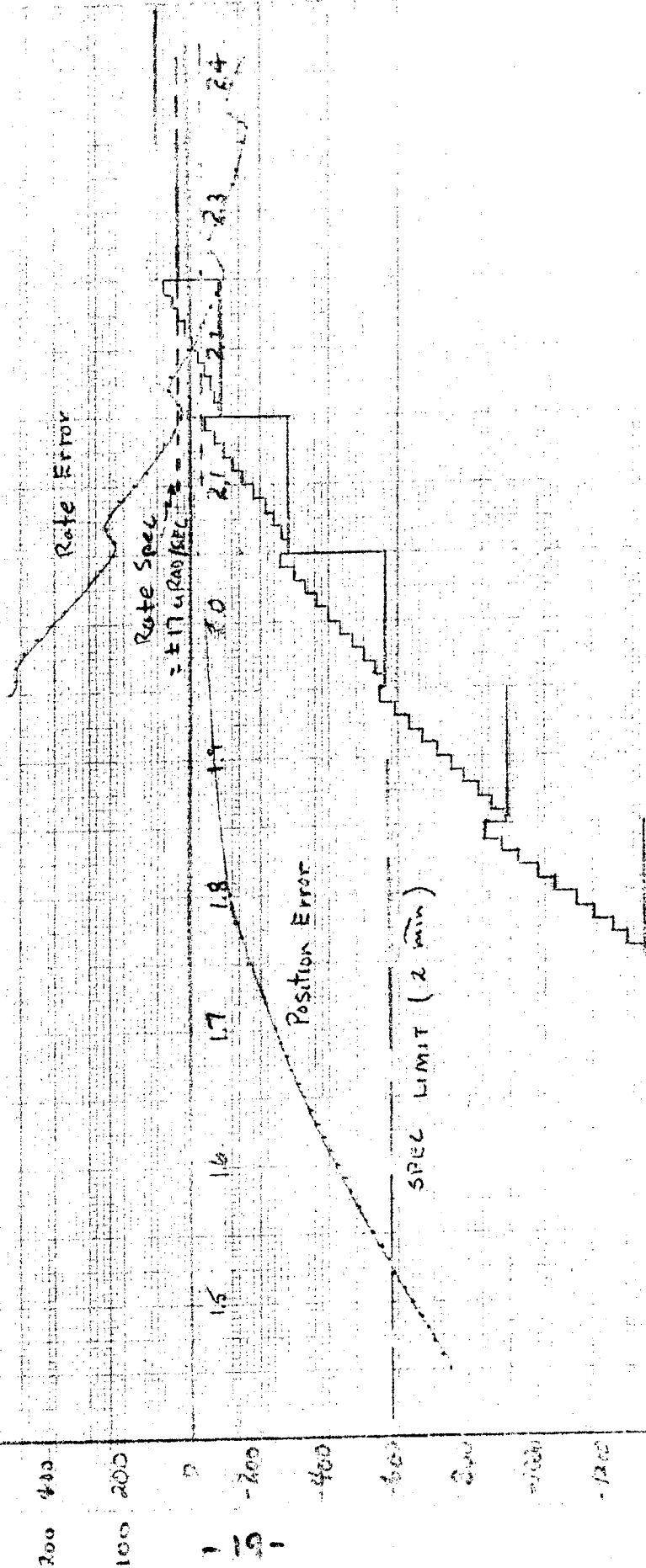

Figure (12)

~~SECRET~~

PROPORTIONAL SAMPLER PROFILE

REPOSITIONING OPERATION

A = MAN'S DELAY 0.015

B = COMPUTER DELAY 0.005

C = COMPUTER DELAY 0.010

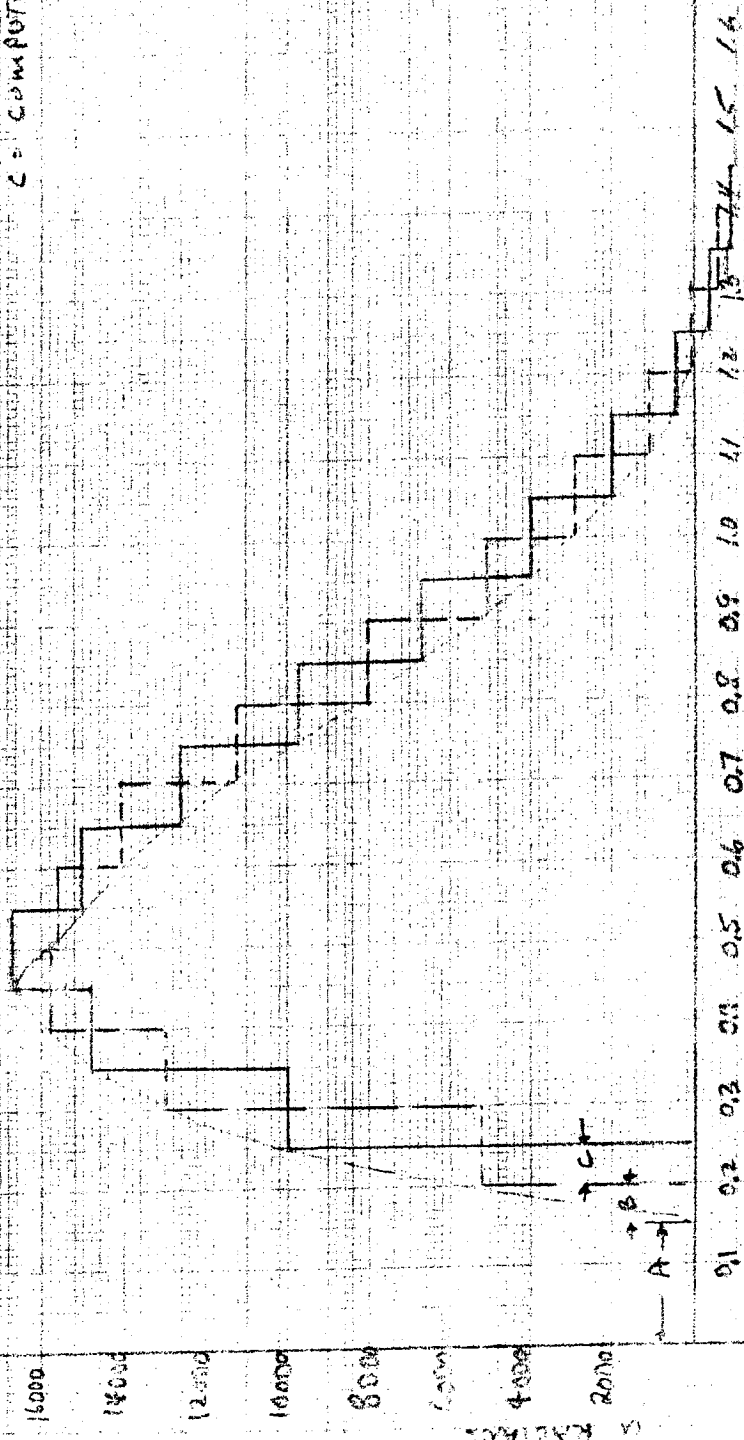

time seconds

~~SECRET~~ PROPORTIONAL SAMPLER PROFILE

DATA OBTAINED 6/18/68 Geo Stokes

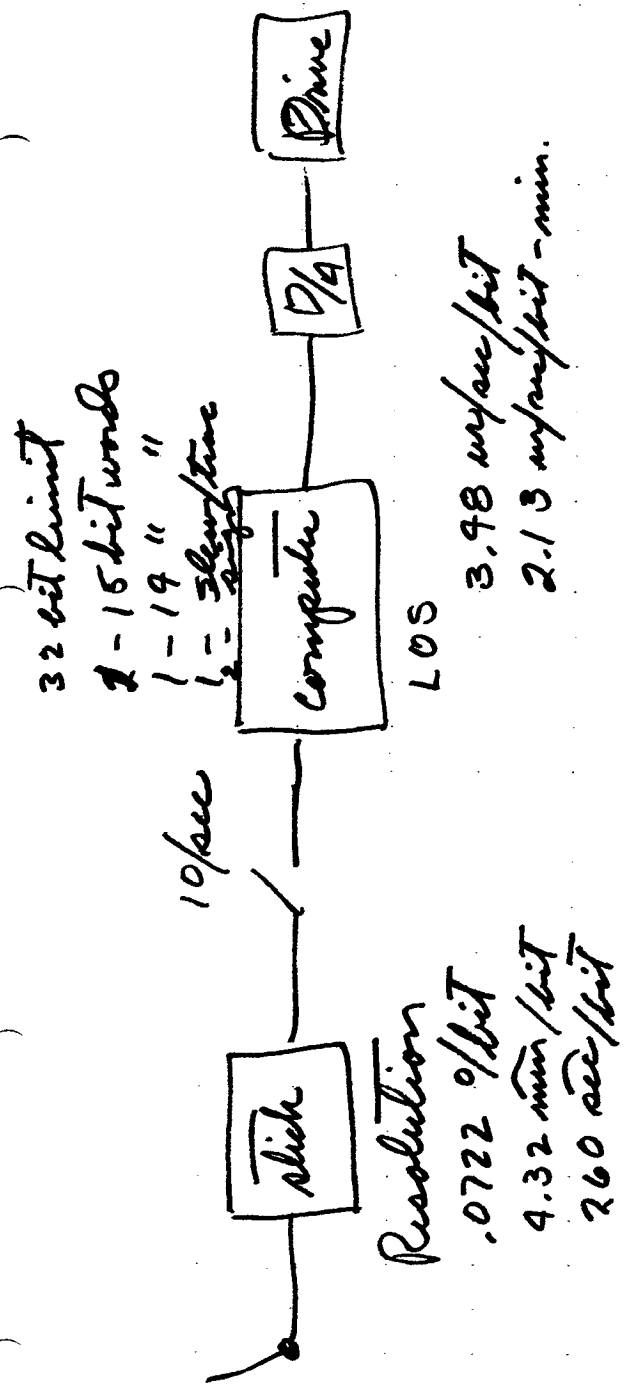

NOTE $\frac{3.50/sec}{2/3} = 1.724 \mu\text{sec/bit}$ not 3.48 $\mu\text{sec/bit}$!

(A) Tracking Gain - 120 m/sec/30° stick travel

$$\therefore \frac{120}{416.5} = .289 \text{ m/sec/bit (stick resolution)}$$

assumed spec - tracking 17 m/sec

To achieve drive resolution - 18 bit computer word

at least 3 additional computer bits (18 bit word length)
 additional computer outputs
 D/A converter change