

HANDLE via BYEMAN  
CONTROL SYSTEM

~~D/SECRET~~

BIF-059-~~9521~~-68  
9521

COPY # 7  
7 PAGES

6

*ITEK*  
Image Velocity  
Sensor Primer

28 AUGUST 1968



SPG-68-086

~~D/SECRET~~

~~500-8-28-3~~  
~~30291-278-1~~  
~~1249-154-1~~

### IMAGE VELOCITY SENSOR PRIMER

#### PRINCIPLE OF OPERATION

The principle of operation of the Itek Image Velocity Sensor (IVS) is that smear resulting from image velocity produces a reduction in the amplitude of the high frequency video power of a television camera (see Fig. 1).

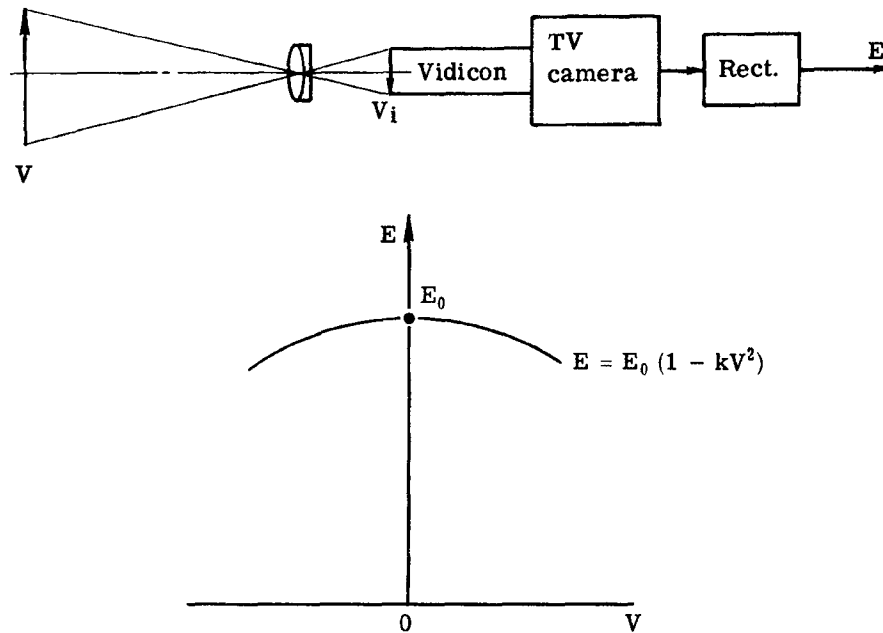

Fig. 1 — Variation of rectified high frequency video signal with image velocity

An object moving with a velocity,  $V_0$ , is imaged by a lens with a magnification,  $M$ , on the sensitive surface of a vidicon television camera (see Fig. 1). The resulting image velocity,  $V = V_0/M$ , causes a reduction in video power. The dependence of the rectified video voltage upon the total velocity,  $V$ , on the vidicon face is given approximately by the expression in Equation (1).

$$E = E_0 (1 - kV^2) \tag{1}$$

HANDLE via BYEMAN  
CONTROL SYSTEM

~~D/SECRET~~

BIF-059-~~9000~~-68  
9521

Consider the resulting velocity if the image velocity,  $V_i$  (resulting from relative motion of the TV camera and the object) is sinusoidally modulated at a circular frequency of  $\omega_m = 2\pi f_m$  with a peak amplitude of  $V_m$ .

$$V = V_i + V_m \sin \omega_m t \quad (2)$$

The resulting expression for the power, after using the trigonometric identity,  $\sin^2 \omega_m t = (1 - \cos 2\omega_m t)/2$ , is given in Equation (3).

$$E = E_0 \left( 1 - kV_i^2 - \frac{kV_m^2}{2} \right) - 2E_0 kV_i V_m \sin \omega_m t + E_0 \frac{kV_m^2}{2} \cos 2\omega_m t \quad (3)$$

Although the amplitude of the fundamental frequency term is linearly dependent on the image velocity, it also depends on the scene information content (i.e.,  $E_0$ ). One method of normalization is to determine the ratio of the amplitude of the fundamental,  $\omega_m$ , to the amplitude of the 2nd harmonic,  $2\omega_m$ , voltages.

$$\frac{E_f}{E_s} = \frac{4E_0 kV_i V_m}{E_0 kV_m^2} = \frac{4V_i}{V_m} \quad (4)$$

Thus, the ratio of the amplitudes of the fundamental and the second harmonic voltages is four times the ratio of the image velocity to the peak modulation velocity.

Another method of normalization is to take the ratio of amplitude of the fundamental to the rectified video voltage and neglect the terms  $kV_i^2$  and  $kV_m^2/2$  which are small compared with unity, so that we obtain:

$$\frac{E_f}{E_0} = 2kV_i V_m \quad (5)$$

To date, studies have principally utilized normalization through the use of the second harmonic.

The following is a list of definitions applied to the above calculations:

- $V$  = total image velocity on vidicon face, in./sec
- $V_i$  = input image velocity, in./sec
- $V_m$  = peak modulation velocity, in./sec
- $\omega = 2\pi f$  = modulation frequency, radians/sec
- $E$  = rectified video voltage
- $E_0$  = rectified video voltage at zero velocity
- $k$  = coefficient, volts/(in./sec)<sup>2</sup>
- $t$  = time, seconds
- $E_f = E_0 2kV_i V_m$  = fundamental amplitude
- $E_s = E_0 k/2 V_m^2$  = second harmonic amplitude

~~D/SECRET~~

### SINGLE-AXIS SENSOR

In the use of this principle in a single-axis sensor (see Fig. 2), the video signal is fed into a high-pass filter which removes the low frequency portions of the signal. This filter is followed by a video amplifier and a full-wave rectifier. The rectified high frequency video signal has a level indicative of the high frequency content of the stored image.

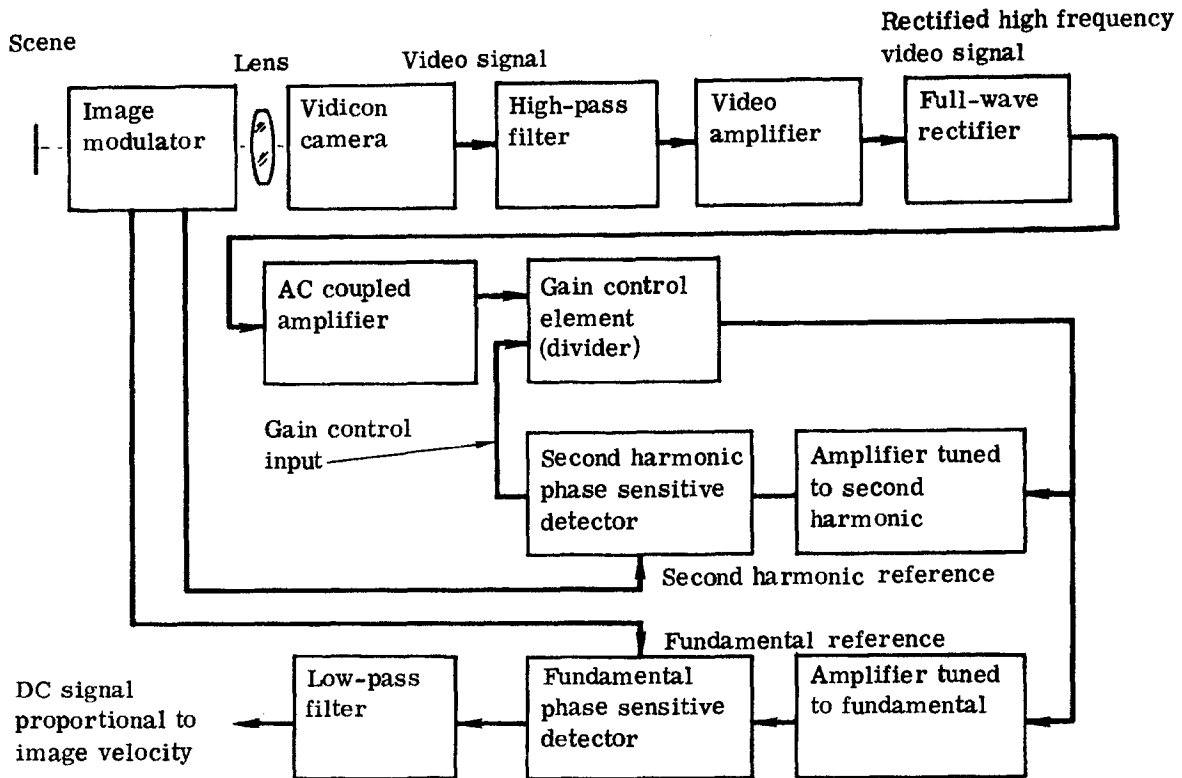

Fig. 2 — Single-axis sensor

Image motion direction sensing is accomplished by phase-sensitive demodulation with a reference signal whose phase is the modulator velocity. The modulator is an oscillating flat plate placed normal both to the optical axis. The rotation axis for modulation is perpendicular to both the optical axis and the vidicon scan direction.

During one half cycle, the modulation velocity adds to the component of image velocity parallel to the modulation direction—during the other half cycle, the velocities subtract. On comparing the video high frequency content of the two half cycles, an output indicating magnitude and direction is obtained for the component of image motion parallel to the modulation direction.

HANDLE via BYEMAN  
CONTROL SYSTEM

~~D/SECRET~~

BIF-059-~~0000~~-68  
9521

### TWO-AXIS SENSOR

For the two-axis sensor, a beam splitter image rotator prism is introduced before the relay lens. This prism presents separate orthogonal images of the original image to a single vidicon camera. Electronic gating, synchronized with the vertical scan, provides two separate velocity signals (see Fig. 3).

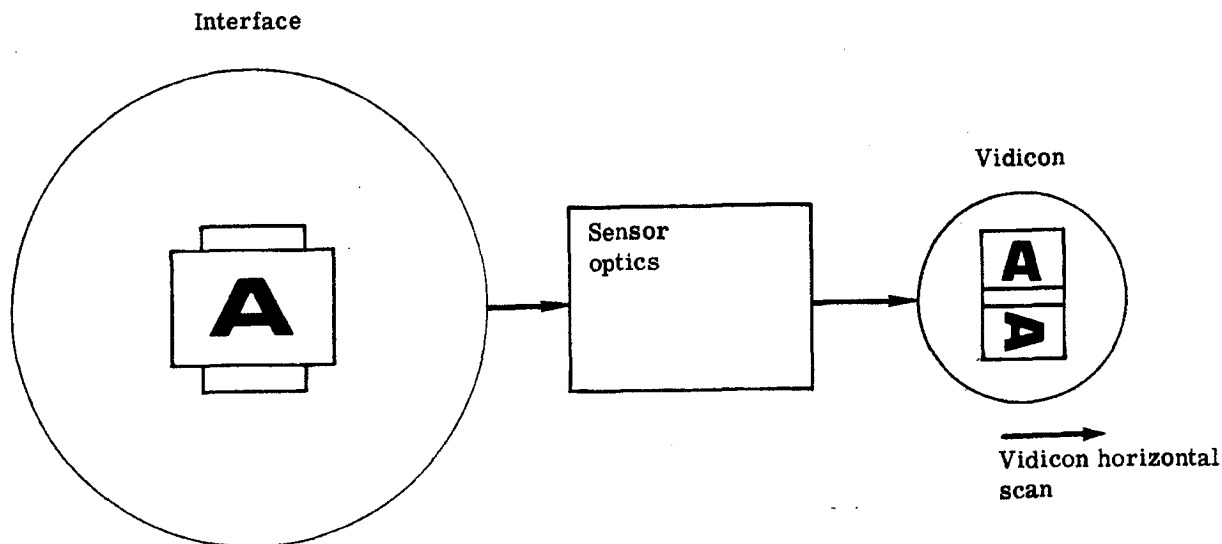

Fig. 3 — Two-axis sensor image handling

In summary, the design is a velocity sensor utilizing a single conventional TV raster scan, sinusoidal modulation, and split image, split field systemology. In addition to the above described equipment, it is anticipated that the vidicon camera will be provided with an image intensifier block to ensure sufficient and constant illumination. This modified camera is referred to as the intensified vidicon (IV).

The sensor head layout is shown in Fig. 4. This unit will perform the following major functions:

1. Provide beam splitting and rotation (90 degrees) of one half of the image
2. Relay the aerial image
3. Velocity modulate the image.

The unit consists of the following major subassemblies:

1. Beam splitter, image rotation prism
2. Modulator assembly
3. Field lens
4. Relay lens
5. Intensified vidicon camera with high voltage power supply
6. Field flattener lens and sealing window.

~~D/SECRET~~

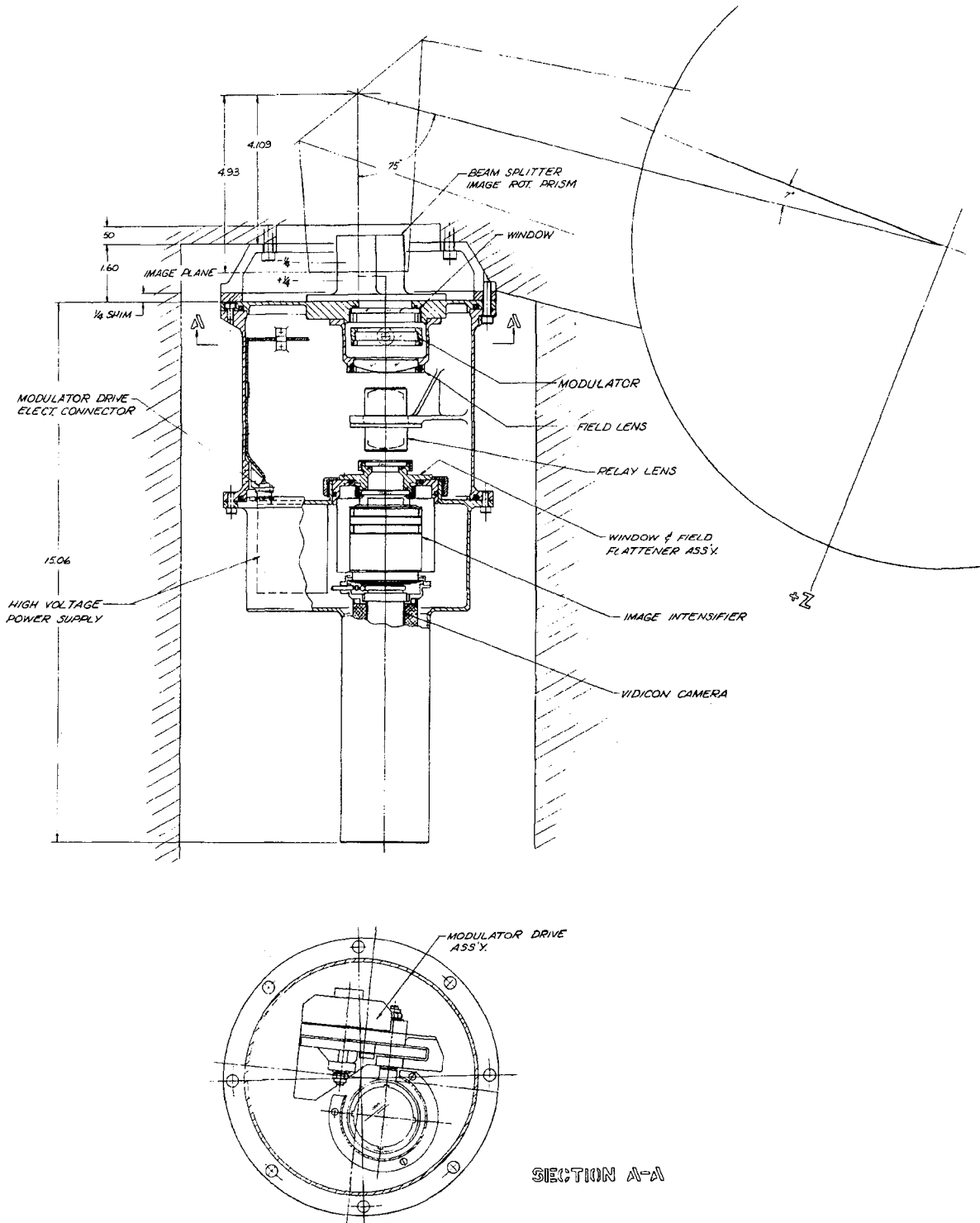

Fig. 4 — Sensor head layout

Physical parameters of the IV are summarized below.

**POWER**

Fig. 5 summarizes the IV power requirements.

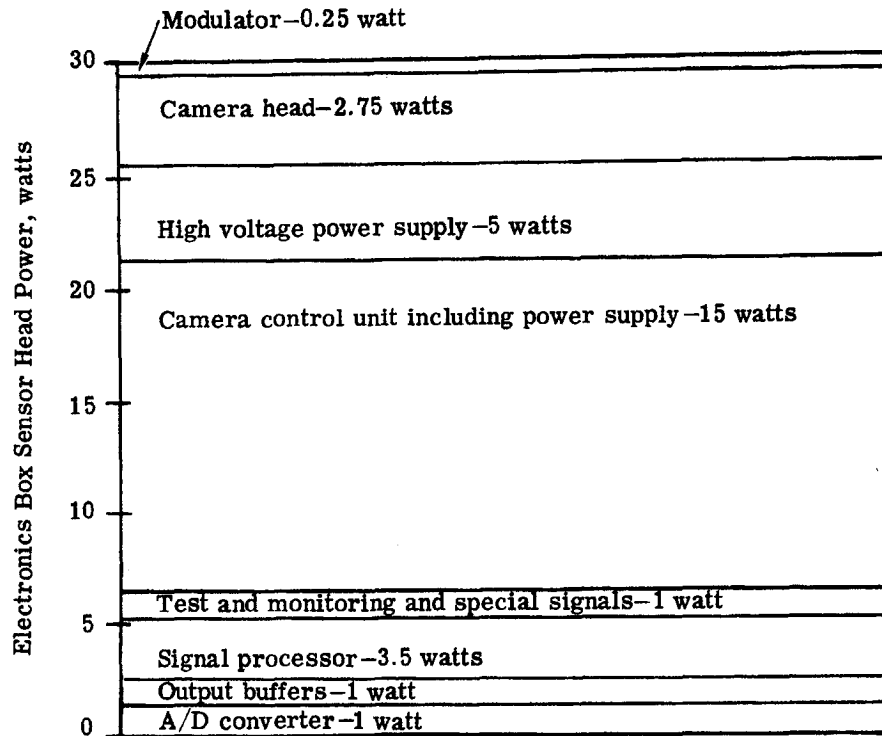

Fig. 5 — IVS power requirements

**SENSOR WEIGHT AND VOLUME**

Weight

Sensor electronics	12.0 pounds
Sensor head	10.7
	<hr/>
	22.7 pounds

Volume

Sensor electronics	6 by 9 by 6 inches
Sensor head	17 inches in length by 7 <sup>5</sup> / <sub>8</sub> inches in diameter

HANDLE via BYEMAN  
CONTROL SYSTEM

~~D/SECRET~~

BIF-059-~~9521~~-68

9521

#### RELIABILITY

96 percent probability for survival	1,112 hours
Mean time before failure	8,000 hours

#### ADVANTAGES

The sensor has excellent threshold velocity detectability under the anticipated operational conditions [i.e., low information content (Wiener Spectra), low illumination, and low contrast]. It requires the use of only a small portion (1.0-inch diameter) of the image area and is thus not appreciably affected by off-axis velocities. It has performed satisfactorily in two laboratory closed loop tracking systems.

#### PROBLEMS

Choice of sensor parameters is complicated by the interaction of each of the design parameters upon the performance characteristics. For example, the increase of modulation amplitude to increase dynamic range causes an increase in null or bias error.

~~D/SECRET~~