

6 June 1969

To: W. C. Williams

Subject: MOL STG Paper

Here is a rough draft copy of the MOL/STG paper prepared at the request of Lt. Col. Skantze last Monday. Skantze carried the data to Gen. Stewart's office Wednesday for coordination and he will bring a "West Coast Coordination" copy back here on Monday (9 June).

C. L. Olson

MOL PROGRAM PERSPECTIVE

1.0 MOL PROGRAM BACKGROUND

1.1 Development Program

1.2 System Growth Potential

2.0 MOL FOLLOW-ON PROGRAM CONSIDERATIONS

2.1 Potential Mission/Payload Improvements

2.1.1 Improved Payload

2.1.2 Enhanced Payload

2.1.3 Advanced Payload

2.1.4 Man's Role in Follow-On Missions

2.1.5 Mission/Payload Summary

2.2 Potential Flight System Improvements

2.2.1 Integral Launch Concepts

2.2.1.1 Improved System (T-IIIM)

2.2.1.2 Growth System (LDC-1)

2.2.2 Resupply Concept

2.2.2.1 Baseline Hardware Derivative (T-IIIM)

2.2.2.2 Advanced Subsystems Concept (T-IIIM)

2.3 "Test-Bed" Applications To In-Space Development

2.3.1 Integral Launch Options

2.3.2 Resupply Options

3.0 POTENTIAL APPLICATIONS OF FUTURE SPACE TRANSPORTATION
SYSTEMS TO MOL

3.1 Background

3.2 Primary Questions Concerning MOL Role In STS

3.3 Possible Role in STS Operating Concepts

3.3.1 Reuseable Logistics Vehicle (RLV) Resupplying An
Orbiting Mission Module (OMM)

3.3.2 Integrated Mission System (IMS)

3.3.3 Space Based Operations

3.4 Studies Needed

4.0 IMPORTANT FACTORS IN POSSIBLE MOL/ STS DECISIONS

4.1 Timing Considerations

4.2 System Cost/Coverage Considerations

5.0 CONCLUSIONS

~~SECRET~~ DORIAN

DIF-107-50241-07
Copy 2 of 6
Page 1
Total Pages: 34
6 June 1969

MOL PROGRAM PERSPECTIVE

1.0 MOL PROGRAM BACKGROUND

1.1 Development Program

The Manned Orbiting Laboratory (MOL) Program was approved in August 1965 with the following objectives:

- O Provide operational intelligence collection at a resolution of [REDACTED]
- O Provide knowledge of the nature and value of the critical contributions of man to photographic reconnaissance and to other military related space missions

These objectives have been reaffirmed by succeeding Secretaries of Defense and Air Force and reviewed by the President in May 1969.

The basic mission of the MOL system is to gather technical intelligence from near-earth orbit. This is accomplished with a 8500 pound, 70 inch aperture [REDACTED] focal length, optical system operated by a two man crew. The optical system will be capable of achieving a photographic ground resolution of [REDACTED] from an altitude of 80 N. Mi.

- 1 -
~~SECRET~~ DORIAN

The MOL Program is currently progressing well. It is totally defined, and all engineering is understood and in being. The Program is meeting all schedule dates, and detailed test results of critical components indicate that system performance specifications required to meet the [redacted] resolution goal will be met or exceeded. With regard to the manned objective, experience to date has increased insight into man's ability, providing high confidence that man will not only make a substantial and quantifiable contribution to photographic reconnaissance but to other related military missions as well. The MOL Program is currently on schedule to achieve the first manned "all up" launch in July 1972, with an additional 3 manned flights to follow at 6-month intervals. The schedule and approved MOL funding are as indicated below.

Table I

MOL Funding

Fiscal Year	70	71	72	73	74
Launches			1	2	1
Funding \$M	525	640	550	397	136

Achievement of all MOL Program objectives is highly predictable, and the system will provide a dramatic increase in the quality and value of satellite reconnaissance. Performance of the MOL crew will establish a wealth of basic understanding, in quantitative terms, of what enhancement and flexibility man can bring to military space operations.

1.2 MOL System Growth Potential

In addition, the basic MOL hardware can provide an impressive potential for performing other military space missions, either with complementary payloads to the basic photographic mission or as completely alternate missions. Furthermore, the existence of a highly sophisticated space qualified manned laboratory can provide a test-bed capability for intensive in-space development of advanced military space systems.

Therefore, on the basis of this emerging DOD manned space system, MOL provides a singular program opportunity to exploit not only the basic photographic reconnaissance mission with significant improvements, but also to provide DOD with a highly flexible means of achieving in minimum time a wide variety of other military space capabilities, both manned and unmanned.

2.0 MOL FOLLOW-ON PROGRAM CONSIDERATIONS

Alternative avenues of growth capability have been defined for the MOL program. These have emphasized improvements in system operating costs, mission flexibility and performance, and effective utilization of man's unique contributions. Future development options in mission equipment, MOL operating modes, and flight system modifications have been appropriately combined to afford smooth and evolutionary transitions, on a timely basis, from the "baseline" development program.

~~SECRET~~ DORIAN

2.1 Potential Mission/Payload Improvements

The Dorian equipment aboard MOL is capable of accomplishing a variety of DOD near-earth space missions. The MOL system would continue to perform its basic technical intelligence task but would also perform such missions as: crisis management, strategic, tactical, and general reconnaissance, economic intelligence, [REDACTED] And, should a future arms control treaty be signed, the MOL would be a valuable asset in monitoring the compliance of other nations with the terms of the treaty. This capability to perform additional missions is achieved by operating the MOL vehicle in a range of orbital altitudes from 70 to 400 N. Mi. and through modifications of the basic flight system and optical payload. In addition, the mission data could be made available in near "real-time" with the addition of a simple wide-band data read-out system to the MOL. The mission capability can be further extended by incorporating additional payload elements into the MOL system. This evolution of MOL mission capability is summarized in Figure 1. Note that optical enhancements could be applied to the "baseline" Dorian or a "growth" system, and true multi-mission capability is inherent in the MOL growth concepts.

2.1.1 Improved Payload

Recent industry studies have indicated that the Dorian system resolution can be increased to [REDACTED] from

~~SECRET~~ DORIAN

~~SECRET~~ DORIAN

80 N. Mi. by modification of the tracking mirror, reducing the optical obstruction, improving the optical formula, and incorporating a central field relay lens to selectively double the focal length. Reducing the optical obstruction also yields a considerable resolution improvement against ground targets with a scene contrast below 2:1. Special films (color, IR), used with the improved system, could produce ground resolutions of [REDACTED] These improvements are estimated to require less than \$50M to accomplish. The weight penalty for the improvements would be approximately 500 pounds.

2.1.2 Enhanced Payload

By changing the optical path of the Dorian system to allow additional sensor access to the image, a variety of infra-red and electro-optical devices can be utilized.

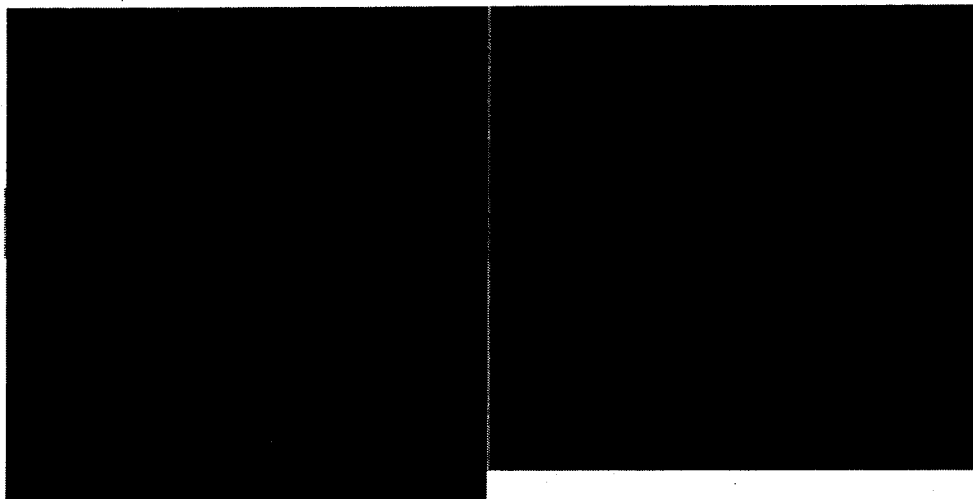

~~SECRET~~ DORIAN

~~SECRET~~ DCRIAN

Since large, Dorian-class optical systems have limited fields-of-view (1° or less), a small camera providing good resolution with wider coverage would be of value in photographing "area" targets or clusters of "point" targets. A 10 inch aperture camera could yield 2.5 foot resolution and a field-of-view in excess of 4 degrees (depending on film format and focal length).

Precision targeting missions could be performed from the MOL by adding a small ranging laser device to accurately determine slant range. Such a slant range determination coupled with precise angular data obtained from a special geodetic camera could provide ground target position data accurate to [REDACTED] in latitude and longitude coordinates and [REDACTED] in altitude. These varied payload enhancements are estimated to cost approximately \$30 million to develop (in addition to the "Improved Payload" cost) and would require about 600 pounds of additional equipment.

A near "real-time" mission capability can be achieved through the addition of a wide-band data return system to the MOL. This system could operate in either the radio or optical spectrum and transmit to earth direct or via a relay satellite. Typical of such systems is an X-Band

~~SECRET~~ DCRIAN

~~SECRET~~ DORIAN

device capable of transmitting about 60 sq. in. of 120 1/mm encrypted pictures/day direct from the MOL to earth or approximately 4,500 sq. inches/day via a data relay satellite. The estimated cost of a MOL wideband system is \$30 million, and is applicable to several alternate methods of wide-band data transmission.

2.1.3 Advanced Payload

The MOL mission equipment module volume is sufficient to allow the Dorian system to "grow" to approximately [REDACTED] in aperture. Enhanced with a variety of sensors, such a system would weigh approximately 18,000 pounds. From 80 N. Mi. the system could achieve a photographic ground resolution [REDACTED]. However, the system could also be flown at 100 N. Mi. and still surpass resolutions achieved with the basic Dorian equipment. Such a growth version of Dorian could be incorporated into the MOL system during the post-1975 time period. The MOL could then operate at higher altitudes more economically and with longer mission durations, and occasionally dip to lower altitudes to achieve maximum resolution.

~~SECRET~~ DORIAN

Similarly, in the 1980 period a very large optical system [REDACTED] could be introduced.

From 80 N. Mi. the system could achieve [REDACTED] [REDACTED] photographic ground resolution; or [REDACTED] could be obtained from 160 N. Mi. While the [REDACTED] system appears near the current state-of-the-art, the [REDACTED] device would require extensive development. Such large optical systems are viewed as distant or "ultimate" goals in the planning of MOL growth.

In addition to optical systems, MOL Advanced Payloads could also include radar and elint packages. Radar would give the system an [REDACTED] capability. In the post-1975 era, radar resolutions of [REDACTED] or better may be achievable. Radar could be used for arms control, crisis management, and surveillance missions. Elint devices aboard MOL could be used to locate active RF targets of interest. [REDACTED]

[REDACTED]

2.1.4 Man's Role In Follow-On Missions

Man's role in follow-on operations will continue to be that of "mission director" aboard the spacecraft. He will select sensors, acquire targets, point and track with the payload elements, select data for near "real-time"

relay to earth, and maintain critical instrument adjustments. Advanced payloads aboard MOL will generally have narrow fields-of-view. Therefore, a target complex will be divided into a collection of individual "aiming points". The crew will study each point to determine if the target is active or inactive and direct the sensor to those "aiming points" with the greatest intelligence value. Such crew activity will maximize the intelligence yield of each MOL mission.

2.1.5 Mission/Payload Summary

In summary, the long term goal of the MOL system is growth to a "general purpose" multi-sensor reconnaissance vehicle capable of accomplishing a variety of missions on demand. Representative follow-on mission and payload groupings are illustrated in Figure 2.

2.2 Potential Flight System Improvements

Alternative means for achieving improvements in MOL system economics and operational utility have been identified, ranging from simple product upgrading of the basic vehicle system to more extensive modifications required for extended orbital operations. Characteristics of most likely flight system options for future MOL growth are summarized in Figure 3. Each flight system illustrated is also capable of operation as an orbital test-bed for development of DOD and NASA advanced mission equipment.

2.2.1 Integral Launch Concepts

Favorable atmospheric conditions predicted for the Post-MOL development program period, along with modest uprating of T-IIIM capability, would permit addition of orbiting vehicle expendables sufficient for a 45 day mission. Orbital duration extensions beyond 60 days, or significant increases in discretionary payload, could be obtained by enlarging the first core stage of the T-IIIM launch vehicle.

2.2.1.1 Improved System (T-IIIM)

The on-orbit duration of the MOL vehicle can be extended to approximately 45 days at 80 N. Mi. by expansion of the unpressurized compartment and addition of MOL tankage for propellant and cryogenic consumables. Such a modification could also be flown at 70 N. Mi. for 30 days or at 90 N. Mi. for about 90 days. Low cost modifications to the T-IIIM booster have been identified which yield adequate launch margins for both orbiting vehicle and payload improvements.

The improved MOL performance characteristics, including payload modifications previously discussed are summarized in Figure 4. Potential

steps toward attainment of the improved system performance goal are itemized in Figure 5, along with estimated development costs for each.

MOL improvement options could be available within thirty-six months following ATP, and would afford a 50% increase in data quantity with up to 30% improvement in data quality. Estimated total cost run-outs and flight schedules for a typical five year program are shown in Table II.

Table II

Block II EDMOL

FY	70	71	72	73	74	75	76	77	78	79
CY	70	71	72	73	74	75	76	77	78	79
Schedule						X X	X X	X X	X X	X X
NR \$ M	10	20	40	40	30	10				
R \$ M		8	51	177	356	420	412	369	243	64
Totals	10	28	91	217	386	430	412	369	243	64

2.2.1.2 Growth System (LDC-1)

Substitution of a fifteen foot diameter core first stage in the T-IIIM would result in a nominal payload increase of 14,000 pounds. This additional payload capability would permit orbital durations in excess of sixty days with the improved MOL payload and modified laboratory vehicle. The operational options attainable by various off-loadings of this configuration are shown in Figure 6. (Eventual deployment of an advanced optical system, capable of resolution [REDACTED] [REDACTED] would also be possible with this MOL option.

The growth system alternative could be available within 36 months from ATP. The estimated development costs for this system total \$320 million of which \$170 million is attributed to laboratory vehicle modifications, \$50 million to mission payload improvements, and \$100 million booster changes. Estimated total cost run-outs and flight schedules for a typical five year program are shown in Table III.

Table III

EDIL

FY	70	71	72	73	74	75	76	77	78	79	
CY		70	71	72	73	74	75	76	77	78	79
Schedule						X X	X X	X X	X X	X X	
NR \$ M	10	40	85	85	80	20					
R \$ M		8	52	181	364	430	422	378	249	66	
Totals	10	48	137	266	444	450	422	378	249	66	

2.2.2 Resupply Concept

An attractive option for increasing discretionary payload capacity and obtaining long duration orbital operations is available through the rendezvous/resupply approach with continued use of the basic T-IIIM launch vehicle. This mode would entail periodic crew rotation and logistic replenishment of a MOL rendezvous initial vehicle (IV), by a rendezvous resupply vehicle (RV) consisting of rearranged MOL hardware elements.

2.2.2.1 Baseline Hardware Derivative (T-IIIM)

The resupply concept consists of an orbiting vehicle, launched initially unmanned to the operational orbit and subsequently manned with a resupply logistics vehicle at regularly spaced periods. The resupplied spacecraft

~~SECRET~~ DORIAN

can be used for continuous year-round mission operations economically since the optical payload is kept on orbit for very extended periods.

By specific tailoring of the resupply expendables, propellant can be made available to permit frequent, repeated on-call reconnaissance of any desired area.

Derivation of the resupply system from basic MOL program hardware segments is illustrated in Figure 7, along with a functional description of the orbiting mission module and resupply vehicle spacecraft.

Outstanding features of this growth alternative include optional operation in intermittent or continuous, manned or unmanned modes; plus the capability of adding additional sensor payloads which will permit multi-mission operations. Major characteristics of the resupply system concept are summarized in Figure 8.

This system concept could be available in four years, at a total estimated development cost of approximately \$800 million. This consists of

~~SECRET~~ DORIAN

\$50 million in payload improvements, \$350 million in resupply vehicle development, \$250 million in laboratory vehicle modifications, and \$150 million for an additional launch facility and associated AGE. Estimated total cost runouts and schedules of a five year program are shown in Table IV.

Table IV

RESUPPLY OPTION

FY	70	71	72	73	74	75	76	77	78	79	
CY		70	71	72	73	74	75	76	77	78	79
Schedule						X Δ Δ	X Δ Δ	X Δ Δ	X Δ Δ	X Δ Δ	
NR \$ M	10	105	174	207	221	83					
R \$ M		10	54	168	344	397	392	348	234	63	
Total	10	115	228	375	565	480	392	348	234	63	

- X Initial Vehicle
- Δ Resupply Vehicle

2.2.2.2 Advanced Subsystem. Concept (T-IIIM)

A substantial reduction in the resupply expendables required could be achieved by the substitution of a [REDACTED] power system for the Baseline cryogenic/fuel cells. By utilizing the weight saved

for additional propellant and discretionary payload, less frequent resupply would be required with attendant reduced operating costs.

2.3 "Test Bed" Applications For In-Space Development

2.3.1 Integral Launch Option

The unique capability of the MOL system for test bed applications can be readily made available for potential NASA and DOD system developers at modest cost. Orbital durations up to 90 days are possible with the integral launch system. Extended operations in the neighborhood of 1 year can be obtained through the resupply option derived from MOL hardware.

Crew size, pressurized compartment volume, and available discretionary payloads, in a variety of combinations is possible, depending on choice of operations or missions desired. Figure 9 depicts two "test bed" vehicle concepts, integral launch and resupply systems; identifying general system characteristics and basic types of development testing that could be performed in these operating modes.

Estimated cost to the user for a basic 30 day MOL, less payload elements, is approximately \$142 million

per flight launched from WTR. Use of this vehicle would entail an initial cost for modifications of approximately \$69 million. Extended duration modifications costing an additional \$125 million would permit integral launch vehicle operations for periods up to 90 days on-orbit at a unit cost of \$150 million per flight. Cost runouts and schedules for the acquisition phase and delivery of the first flight system are displayed on Tables V and VI for the 30 day and 90 day systems respectively.

Table V

30 DAY VEHICLE TEST BED OPTION

FY	70	71	72	73	74	75	76	77	78	79	
CY		70	71	72	73	74	75	76	77	78	79
Schedule						X					
NR \$ M		20	23	12	9	5					
R \$ M		5	22	50	56	9					
Total		25	45	62	65	14					

Table VI

90 DAY VEHICLE TEST BED OPTION :

FY	70	71	72	73	74	75	76	77	78	79	
CY		70	71	72	73	74	75	76	77	78	79
Schedule						X					
NR \$ M	10	38	55	54	53	14					
R \$ M		5	23	53	59	10					
Total	10	43	78	107	112	24					

Operations at ETR are possible with addition of some facilities at KFC. An attendant increase in discretionary payloads of approximately 20% can be derived from this option.

2.3.2 Resupply Options

The resupply concept cost varies with requirements for crew size, pressure compartment volume, and operational site selection. A basic two crewmen system, using the single compartment Laboratory (Initial Vehicle), less military payload element, is approximately \$172 million for Laboratory Vehicle and \$110 million for the Resupply Vehicle launched from WTR. Cost of modifications to the Laboratory vehicle for one year on-orbit life and the repackaging/development of the Resupply Vehicle is estimated at \$300 million.

Additional pressurized compartment volume to support a crew size of four would require an additional \$110 million in engineering development and flight test. For operations from ETR, certain additional launch site facilities would be required with an estimated cost of \$120 million. These options can provide increased test capability and discretionary payload if desired. Cost runouts and schedules for system acquisition and delivery of first flight article are displayed on Table VII.

Table VII
RESUPPLY SYSTEM TEST BED OPTION

FY	70	71	72	73	74	75	76	77	78	79
CY	70	71	72	73	74	75	76	77	78	79
Schedule						X _Δ				
NR \$ M	10	67	80	63	60	20				
R \$ M $\frac{IV}{RV}$		6 3	26 10	61 36	68 53	11 8				
Total	10	76	116	160	181	39				

X Initial Vehicle
Δ Resupply Vehicle

3.0 POTENTIAL APPLICATIONS OF FUTURE SPACE TRANSPORTATION SYSTEMS TO MOL

3.1 Background

It has become increasingly clear that space transportation costs may constitute a limiting factor on the amount and type of space exploratory activities which may be undertaken in the future. The search for a more favorable plateau of space operations costs has recently stimulated significant studies, by both the NASA and the DOD, of concepts for economical transportation systems which will operate between Earth and future space stations.

3.2 Primary Questions Concerning MOL Role In STS

The potential development of a National space transportation system could offer significant advantages to future MOL mission operations in terms of reduced costs and increased mission flexibility; also, the imposition of future MOL requirements on such a system design could entail large impact on system selection. Since space transport concepts which exhibit low

~~SECRET~~ DORIAN

potential operating costs will require development funds totaling many billions of dollars and development time spans approaching a decade, the central question concerns the degree of involvement which is appropriate to the MOL program and is justifiable in view of available, well defined, near-term program growth options.

Subsidiary questions concern the relative desirability of various potential operating modes for the MOL mission with each of the space transportation systems currently proposed by DOD and NASA. These questions bear upon the relationship between the MOL payload module and the reuseable transport vehicle, since the flight configuration and operating mode eventually selected would have a most pronounced influence on required MOL payload modifications and on the adaptability of a MOL/STS system to future growth mission needs. Converseley, it is not evident that a space transport system designed primarily for efficient conduct of advanced manned multi-sensor reconnaissance missions could be utilized satisfactorily by the predicated large population of users with widely varying requirements.

Informed answers to these questions must await adequate study of at least the MOL/STS operating concepts summarized in the following section.

3.3 Possible Role in STS Operating Concepts

The wide range of flight system concepts which are currently under consideration by NASA and DOD for potential space transport applications gives rise to an even more extensive matrix of possible MOL/STS operating modes. Some of these modes are illustrated in Figure 10 (along with the MOL growth family. Three major classes of operating concepts are summarized below.

3.3.1 Reuseable Logistics Vehicle (RLV) Resupplying An Orbiting Mission Module (OMM)

One attractive mode would entail orbiting a MOL mission payload module (OMM) which is capable of operating manned or unmanned and is storable on orbit, and supplying crew and expendable requirements with a comparatively simple reuseable logistics vehicle (RLV) of 10,000 - 12,000 pound discretionary payload capacity. This mode of operation is similar to that described in section 2.2.2., with the added feature of resupply vehicle reuseability.

3.3.2 Integrated Mission System (IMS)

An alternative operating mode would envision installation of a complete MOL payload and supporting equipments in a relatively large and complex reuseable flight system. If the operating mode involved ejection of the MOL payload and supporting equipment on orbit, with subsequent

autonomous functioning of the payload module, the required discretionary payload capacity would range from 40,000 pounds to 50,000 pounds. In an operating mode based upon full functional integration of the MOL mission payload and flight vehicle system the required discretionary payload capacity would be in the 25,000 pound to 35,000 pound range.

3.3.3 Space Based Operations

A third potential mode of future operation, contingent upon availability of a national orbiting space facility in near polar orbit, would entail operation and support of a MOL module from the space station, either directly or through use of orbit-to-orbit shuttle vehicles.

Possible advantages of this operating mode are presently unclear.

3.4 Studies Needed

The impact of MOL requirements on detail selection of a future multi-user national space transportation system is expected to be profound. Additionally, the potential future availability of a low cost flight system could exert a strong influence on the direction of MOL near-term follow-on program plans. Extensive and in-depth studies are required to assess the relative utility of the potential flight systems to future MOL operations, and to place them in clear context with current MOL evolutionary growth concepts.

4.0 IMPORTANT FACTORS IN POSSIBLE MOL/STS DECISIONS

4.1 Timing Considerations

Under the most optimistic circumstances which might attend development of a future National STS, a hiatus in manned military space flight of three to five years would follow the conclusion of the currently programmed MOL flights. This gap is illustrated in Figure 11. Since it is clearly in the national interest to continue the MOL reconnaissance mission during this period, a minimum MOL-continuation budget requirement of 400-500 million dollars per year can be predicted. The forty-five month lead time associated with any MOL follow-on alternative indicates that some funds for such commitments must be allocated in FY 1970. These considerations, taken along with the evident trend toward reduction of space operations funding, would appear to limit any incentive for MOL consideration of advanced space transportation system development at this time.

4.2 System Cost/Coverage Considerations

Figure 12 furnishes a brief description of the flight systems which form the basis for Potential MOL Program Alternatives Cost Summary contained in Figure 13. The latter figure displays total estimated additional MOL costs for nominal ten year operational programs in terms of percent of annual orbital coverage time desired. Flight systems included for comparison are the three MOL evolutionary derivatives and three generic candidates for future space transport applications. All estimated

~~SECRET~~ DORIAN

costs include development and operation at a launch rate defined by the indicated coverage requirements and by the flight system characteristics. Payload integration costs are included in each system estimate.

The system cost summary shows that the most economic operation for coverages up to two months is provided by either of the integral launch MOL derivative systems. For coverage requirements between two months and seven months per year, the MOL-derived resupply system is least costly. (The reusable resupply system is excluded here due to high development cost.) The advanced reusable system concepts would provide the most economical operation only if near-continuous orbital coverage over the nominal ten year period were the criterion.

It is clear from the cost summary data, however, that availability of an advanced transportation system at limited acquisition cost to the MOL could result in future significant operating cost savings across the entire coverage spectrum. Therefore, MOL requirements should be given full consideration in system formulation if a National space transportation system development is authorized.

5.0 CONCLUSIONS

- 5.1 MOL is a viable and unique program which will develop the potential of man's contribution to current and future military space objectives.

~~SECRET~~ DORIAN

~~SECRET~~ DORIAN

- 5.2 The MOL system forms a keystone upon which DOD space goals for the next decade should be constructed. As such, it merits high priority funding consideration with respect to competing National programs.
- 5.3 The MOL System has growth potential to achieve a "general purpose" multi-sensor capability. A wide range of realistic future missions can be achieved with minor modifications to the basic MOL payload.
- 5.4 The MOL flight system elements can be operated in a variety of modes consistent with future DOD mission demands, improved operating economics, National manned space flight goals, and early availability requirements.
- 5.5 Deployment and operation of MOL mission payload elements with proposed reusable space transport systems of the late seventies time period could offer significant reductions in annual operating cost.
- 5.6 In view of the available, well defined near-term MOL growth options, and of the stringent current funding environment, it does not appear justifiable for the MOL Program to consider sharing development costs for a future space transportation system. This conclusion is amplified by the funding commitments required to ensure continuation of the MOL reconnaissance capability in the post-baseline period.

~~SECRET~~ DORIAN

- 5.7 A study is needed to define MOL follow-on requirements in the context of manned and unmanned MOL evolutionary systems and of the program impacts which would result from potential availability of a National Space Transport System. Scope and depth of the study should be such as to permit formulation of a comprehensive manned military space plan, including defined responses to a range of possible National decisions for future manned space systems.

~~SECRET~~ DORIAN

FIGURE 1

~~SECRET~~/DORIAN

1975-85 DOD NEAR EARTH MISSION/PAYLOAD MIX
(NEAR POLAR OPERATION, 70 < h < 400 N. MI.)

PAYLOAD ELEMENTS

MOL/DORIAN ENHANCED OPTICS

- 70 IN. APER. WITH [REDACTED] SYSTEM

AUGMENTED WITH: ● OPTICS WITH F. O. V. > 3°

- FOCAL PLANE/LIGHT PATH MODS

✓ SPECIAL FILM

✓ IR [REDACTED]

✓ ELECTRO-OPTICS

- INTEGRATED VIEWING

- LASER RANGING

- ALSO f (VEHICLE) {
- WIDE-BAND COMM.
 - PREC. NAVIGATION/POINTING
 - ΔV FOR MANEUVERS

RADAR/RF DEVICES

- [REDACTED] RADARS
- ELINT/COMINT DEVICES

ADDITIONAL PAYLOADS

- RMU, OFFENSIVE/DEFENSIVE WEAPONS
- SUPPORT, PAYLOAD TEST & DEVELOPMENT ELEMENTS

MISSION ELEMENTS

TECHNICAL INTELLIGENCE

[REDACTED]

STRATEGIC RECONNAISSANCE

TACTICAL RECONNAISSANCE

(ECONOMIC INTELLIGENCE)

TARGETING

GENERAL RECONNAISSANCE

CRISIS MANAGEMENT

OCEAN SURVEILLANCE
ARMS CONTROL

[REDACTED]
OFF. & DEF. FORCE STRUCTURE
R&D

~~SECRET~~/DORIAN

HANDLE VIA BYEMAN
CONTROL SYSTEM ONLY

FIGURE 2

~~SECRET~~/DORIAN

REPRESENTATIVE MOL MISSION AND PAYLOAD GROUPINGS

PAYLOAD GROUP	REPRESENTATIVE PERFORMANCE FROM 80 N. MI.	ESTIMATED PAYLOAD WGT. (LBS)	TYPICAL MISSION CAPABILITY
<p>I</p> <p><u>IMPROVED DORIAN</u></p> <ul style="list-style-type: none"> • INCREASED PRIMARY RESOLUTION • SPECIAL FILM 	<ul style="list-style-type: none"> • [REDACTED] • [REDACTED] 	<p>9,000</p>	<p>TECHNICAL INTELLIGENCE</p> <p>[REDACTED]</p>
<p>II</p> <p><u>ENHANCED DORIAN</u></p> <ul style="list-style-type: none"> • INCREASED RESOLUTION • SPECIAL FILM • LOW RES SYSTEM • INFRA-RED • ELECTRO-OPTICS • LASER RANGING 	<ul style="list-style-type: none"> • [REDACTED] • [REDACTED] • [REDACTED] • [REDACTED] • [REDACTED] • [REDACTED] 	<p>9,600</p>	<p>TECHNICAL INTELLIGENCE</p> <p>[REDACTED]</p> <p>STRATEGIC RECONN. TACTICAL RECONN. ECONOMIC INTELLIGENCE GENERAL RECONN. TARGETING CRISIS MANAGEMENT</p>
<p>III</p> <p><u>ADVANCED DORIAN</u></p> <p>[REDACTED] CLASS PAYLOAD ENHANCED WITH PAYLOAD ELEMENTS OF GROUP II</p>	<ul style="list-style-type: none"> • PRIMARY RES. OF [REDACTED] AS GRG WITH OBJECTIVE PERF. OF ENHANCED PAYLOAD IMPROVED APPROX. [REDACTED] 	<p>~18,000</p>	<p>[REDACTED]</p>
<p>IV</p> <p><u>ADVANCED MISSIONS</u></p> <p>ABOVE TOGETHER WITH RADAR, HIGH ΔV, ELINT DEVICES, AND SUPPORTING SYSTEMS</p>	<ul style="list-style-type: none"> • COMPLETE LOW-EARTH (h < 400 N. MI.) MISSION CAPABILITY <p>SECRET/DORIAN</p>	<p>< 25,000 TO 30,000 LBS.</p>	<p>ARMS CONTROL OCEAN SURVEILLANCE</p> <p>[REDACTED]</p>

HANDLE VIA BYEMAN CONTROL SYSTEM ONLY

"PAYLOAD" = MPSS HARDWARE ONLY

FIGURE 3

MOL SYSTEM PERSPECTIVE FOR POTENTIAL DOD MISSIONS

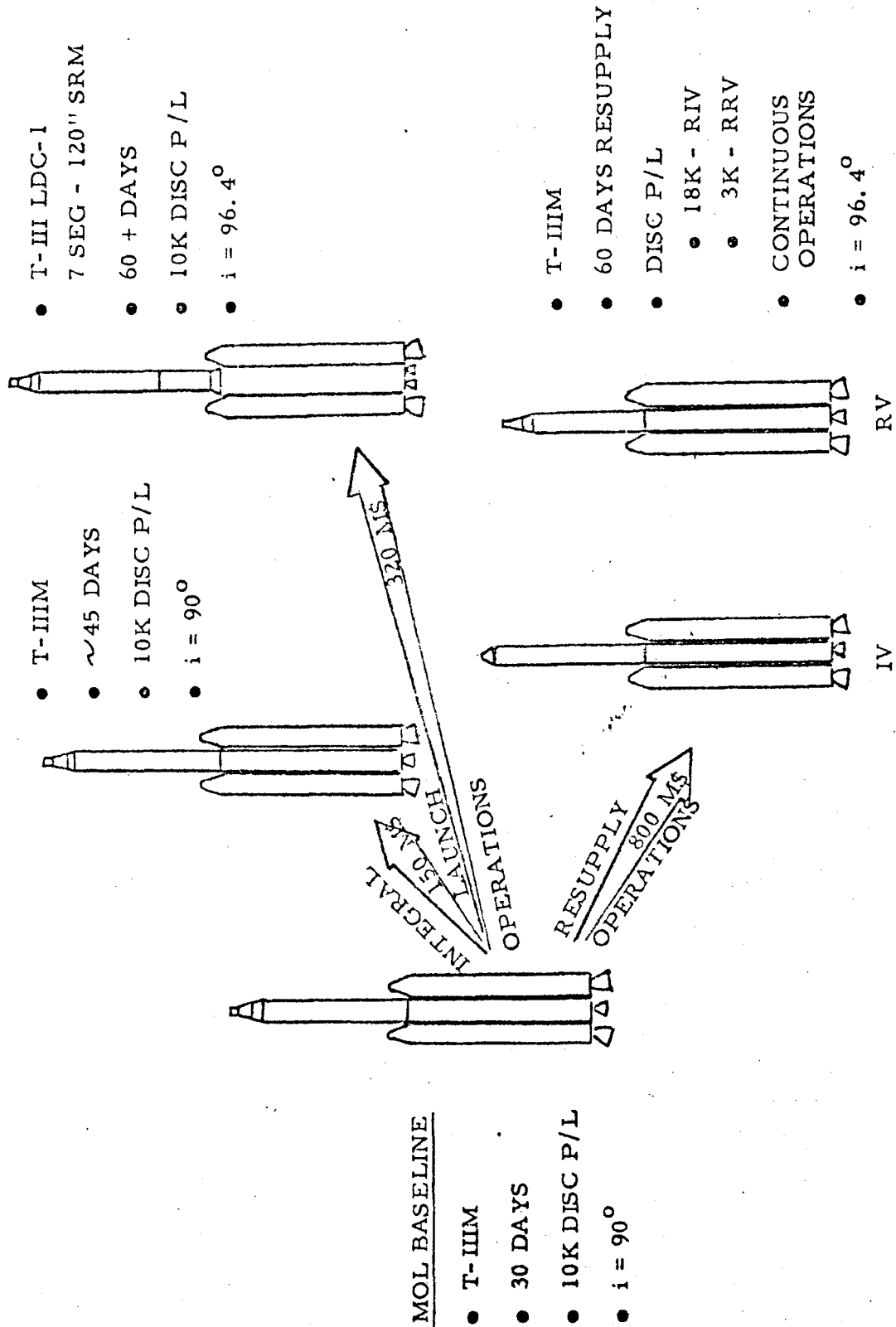
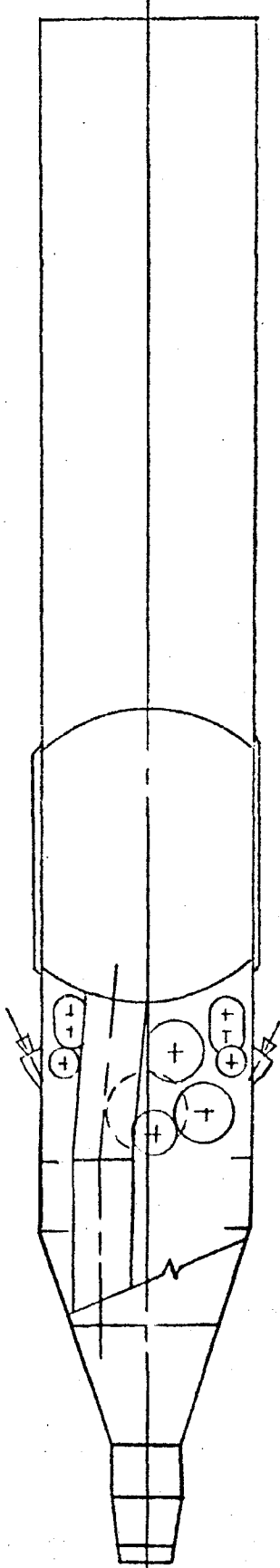

FIGURE 4

~~SECRET~~/DORIAN

POSSIBLE BLOCK II MOL OPERATING OPTIONS AND CHARACTERISTICS

- ✓ ADDITIONAL EXPENDABLES
- ✓ PAYLOAD IMPROVEMENTS



MISSION

DURATION

PERIGEE ALTITUDE

OPTICAL RESOLUTION

BASELINE IMPROVED

- NOMINAL 45 DAYS 80 MILES
- LOW FLIGHT 30 DAYS 70 MILES
- EXTENDED DURATION 60 DAYS 90 MILES



HANDLE VIA BYEMAN CONTROL SYSTEM ONLY

~~SECRET~~/DORIAN

FIGURE 5

~~SECRET~~/DORIAN

IMPROVEMENT POTENTIAL

BLOCK II MOL

BASELINE

- ✓ [REDACTED]
- ✓ 30 DAYS
- ✓ 80 N. MI.

LOW-FLY

- ✓ [REDACTED]
- ✓ REDUCED DURATION
- ✓ 70 N. MI.

T-IIIM IMPROVEMENTS

- ✓ 680 #(CORE)
- ✓ 2000 #(SRM)
- \$4 M

P/L IMPR.

- ✓ [REDACTED]
- ✓ 30 DAYS
- ✓ 80 N. MI.
- \$50 M

EDMOL/LOW-FLY

- ✓ [REDACTED]
- ✓ 45/30 DAYS
- ✓ 80/70 N. MI.
- \$90M (EDMOL)
- \$100M (EDMOL + LOW-FLY)

"GOAL"

P/L + EDMOL/LOW-FLY

- ✓ [REDACTED]
- ✓ 45/30 DAYS
- ✓ 80/70 N. MI.
- \$150 M

HANDLE VIA BYEMAN CONTROL SYSTEM ONLY

~~SECRET~~/DORIAN

FIGURE 6

EXTENDED DURATION INTEGRAL LAUNCH (EDIL)

• LAUNCH DATE ~ 1974

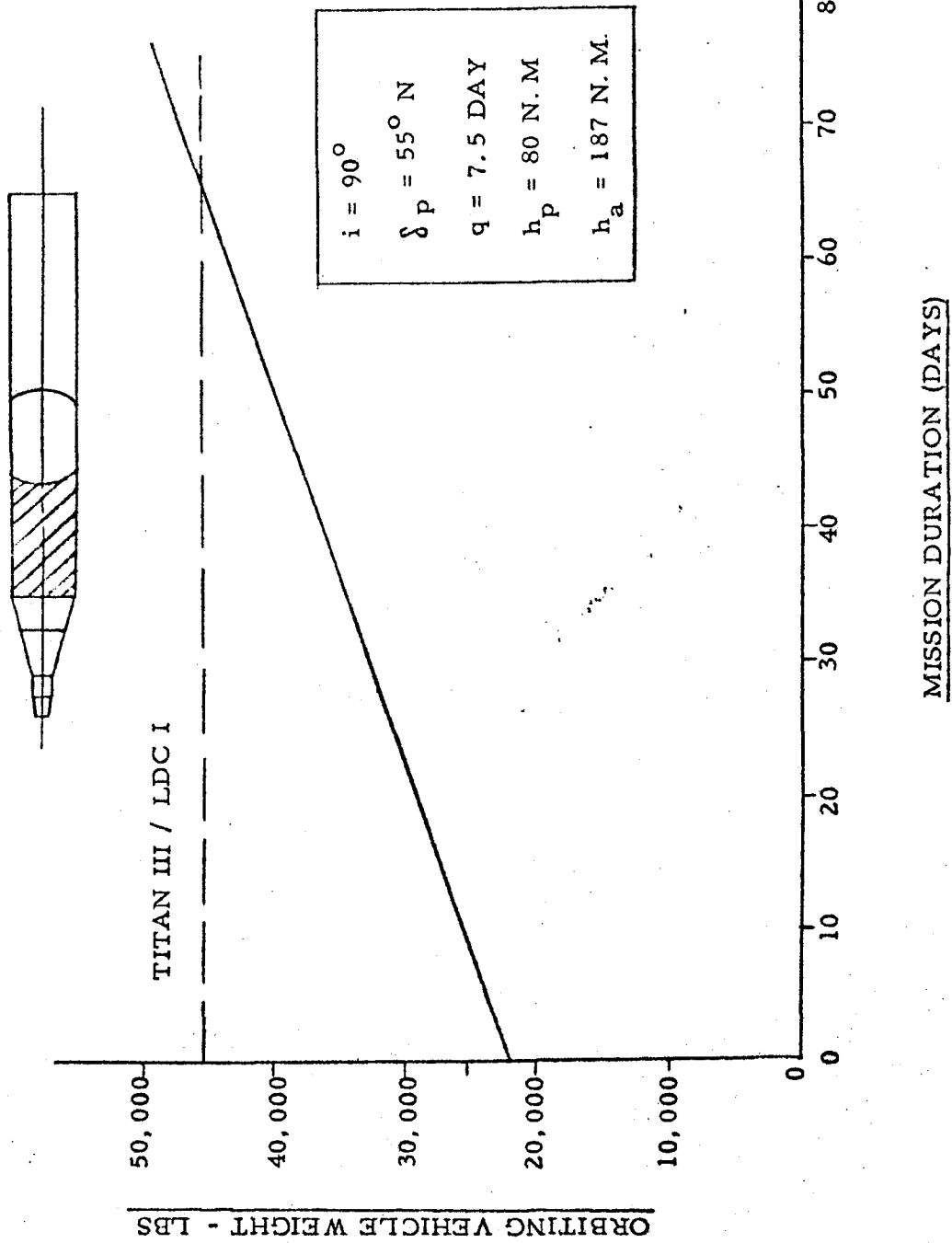
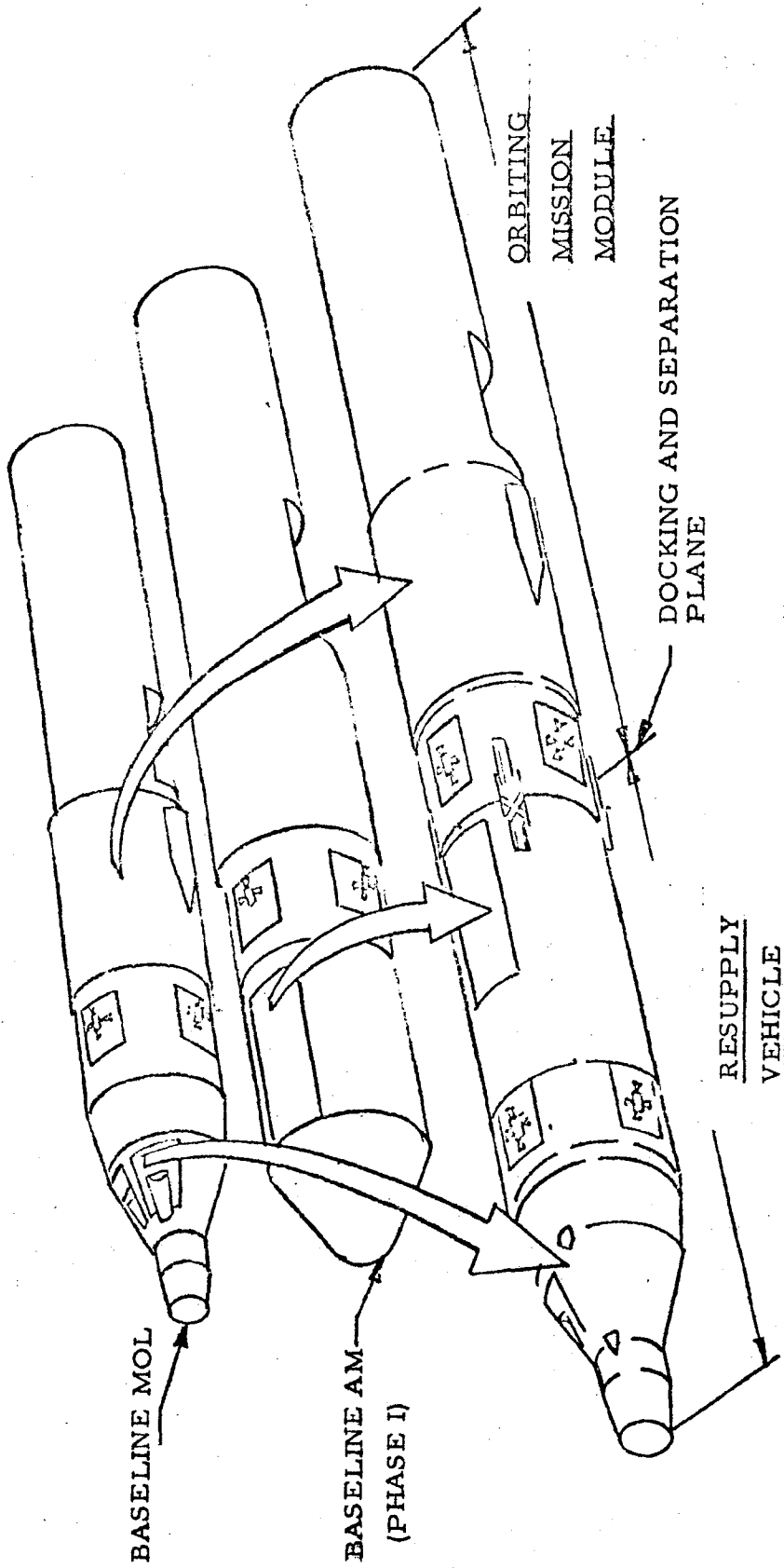

FIGURE 7

D ~~SECRET~~ SPECIAL HANDLING
MOL RENDEZVOUS ORBITING VEHICLE EVOLUTION



RV FUNCTIONS

- CREW TRANSPORT VEHICLE
- ACTS PROPULSION
- PRIME POWER SYSTEM
- LIFE SUPPORT EXPENDABLES
- DATA RETURN SYSTEM
- SUBSYSTEM SPARES/REPLACEMENTS

OMM FUNCTIONS

- LIFE SUPPORT SYSTEM
- ATTITUDE CONTROL REFERENCE/ELECTRONICS
- COMMUNICATIONS AND DATA HANDLING
- ENVIRONMENTAL CONTROL
- HRO SYSTEM

FIGURE 8

~~SECRET~~/DORIAN

POSSIBLE BLOCK III MOL OPERATING OPTIONS AND CHARACTERISTICS

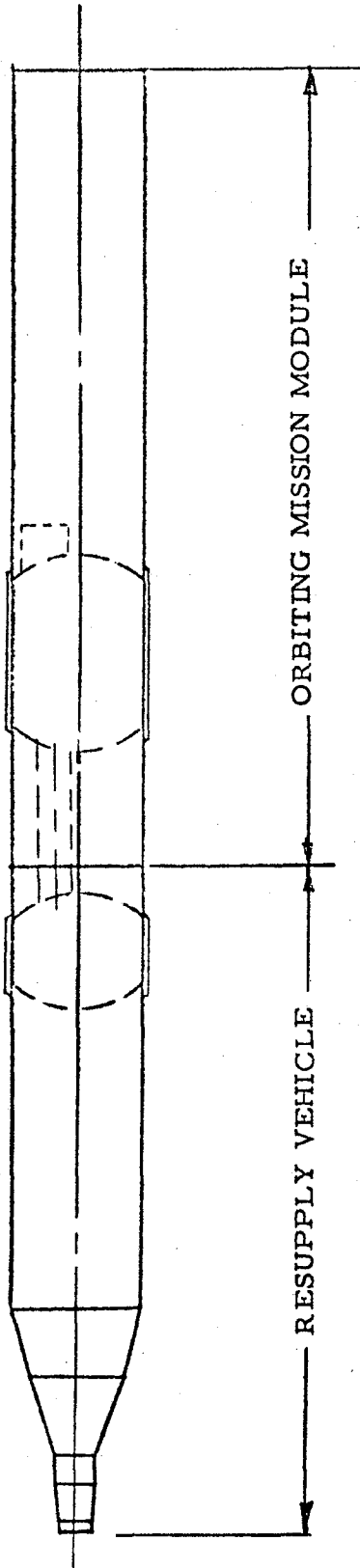

- INTERMITTENT OR CONTINUOUS OPERATIONS
/ MANNED OR UNMANNED
- RESUPPLY/CREW ROTATION (60/90 DAYS)
- OMM OPERATING LIFE > 1 YEAR
- ENHANCED OR ADVANCED HRO
- POTENTIAL FOR MULTIPLE MISSION ELEMENTS

HANDLE VIA BYEMAN
CONTROL SYSTEM ONLY

~~SECRET~~/DORIAN

FIGURE 9

~~SECRET~~/DORIAN

POTENTIAL MOL "TEST BED" UTILIZATION CONCEPTS (DOD/NASA)

(200 N. Mi., $i = 90^\circ$, WTR)

VEHICLE CHARACTERISTICS

POSSIBLE DEVELOPMENTAL TESTS

• INTEGRAL LAUNCH

• DISCRETIONARY P/L

✓ 30 DAY 11,000 LBS
 ✓ 90 DAY 4,250 LBS



- TWO MEN
 - 30-90 DAYS
 - 1000 CU. FT. PRESS. VOL.
 - TITAN IIIM
- COSTS
- ✓ N/R \$69M (30 DAY)
 - ✓ R \$125M(90 DAY)
 - ✓ R \$142-\$150M

• RESUPPLY



RIV RRV

- FOUR MEN
 - ONE YEAR LABORATORY
 - VOLUME
 - ✓ 2700 CU. FT. PRESS VOLUME - RIV
 - ✓ 1000 CU. Ft. PRESS VOLUME - RRV
 - TITAN III-M
 - 60 TO 90 RESUPPLY CYCLE
- DISCRETIONARY P/L
- ✓ RIV 20,000 LBS
 - ✓ RRV 5,500 LBS
- COSTS
- ✓ N/R \$50M (RIV)
 - ✓ R \$250 M (RRV)
 - ✓ R \$172M (RIV)
 - ✓ R \$110M (RRV)

- LONG DURATION BIOMEDICAL
- EARTH RESOURCES SENSORS
- ASTRONOMY SENSORS
- ARTIFICIAL GRAVITY DEVICE
- MANNED SPACE MAINTENANCE CONCEPTS AND EQUIPMENT
- ADVANCED RADAR SYSTEMS
- RECONNAISSANCE SYSTEMS
- UNMANNED SATELLITE SYSTEMS EQUIPMENT
- COMMUNICATION SYSTEMS
- TACTICAL AND STRATEGIC WEAPONS ELEMENTS
- IN-SPACE MANUFACTURING CONCEPTS AND EQUIPMENT
- MATERIALS RESEARCH

~~SECRET~~/DORIAN

HANDLE VIA BYEMAN CONTROL SYSTEM ONLY

POTENTIAL FLIGHT SYSTEMS AND OPERATING CONCEPTS

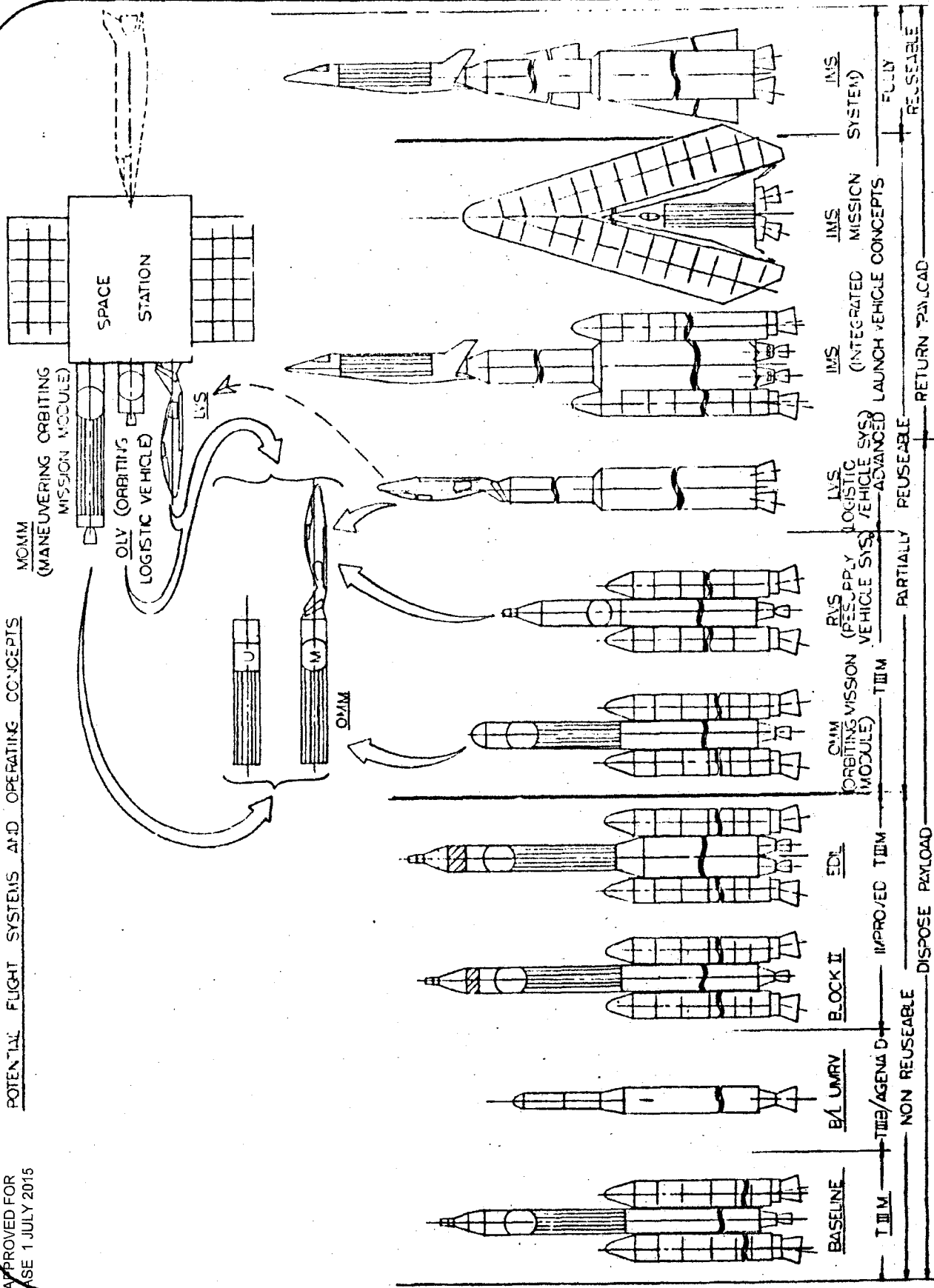

BASELINE
T.I.M.
IMPROVED T.I.M.
EDL
ORBITING MISSION (MODULE)
RVS (RESUPPLY VEHICLE SYS)
LVS (LOGISTIC VEHICLE SYS)
ADVANCED LAUNCH VEHICLE CONCEPTS
IMS (INTEGRATED MISSION SYSTEM)
IMS (SYSTEM)
FULLY REUSABLE
RETURN PAYLOAD

B/L UMRV

BLOCK II

EDL

ORBITING MISSION (MODULE)

RVS (RESUPPLY VEHICLE SYS)

LVS (LOGISTIC VEHICLE SYS)

ADVANCED LAUNCH VEHICLE CONCEPTS

IMS (INTEGRATED MISSION SYSTEM)

IMS (SYSTEM)

FULLY REUSABLE

RETURN PAYLOAD

FIGURE II

MANNED SPACE SYSTEMS PLANNING PERSPECTIVE

(1969)

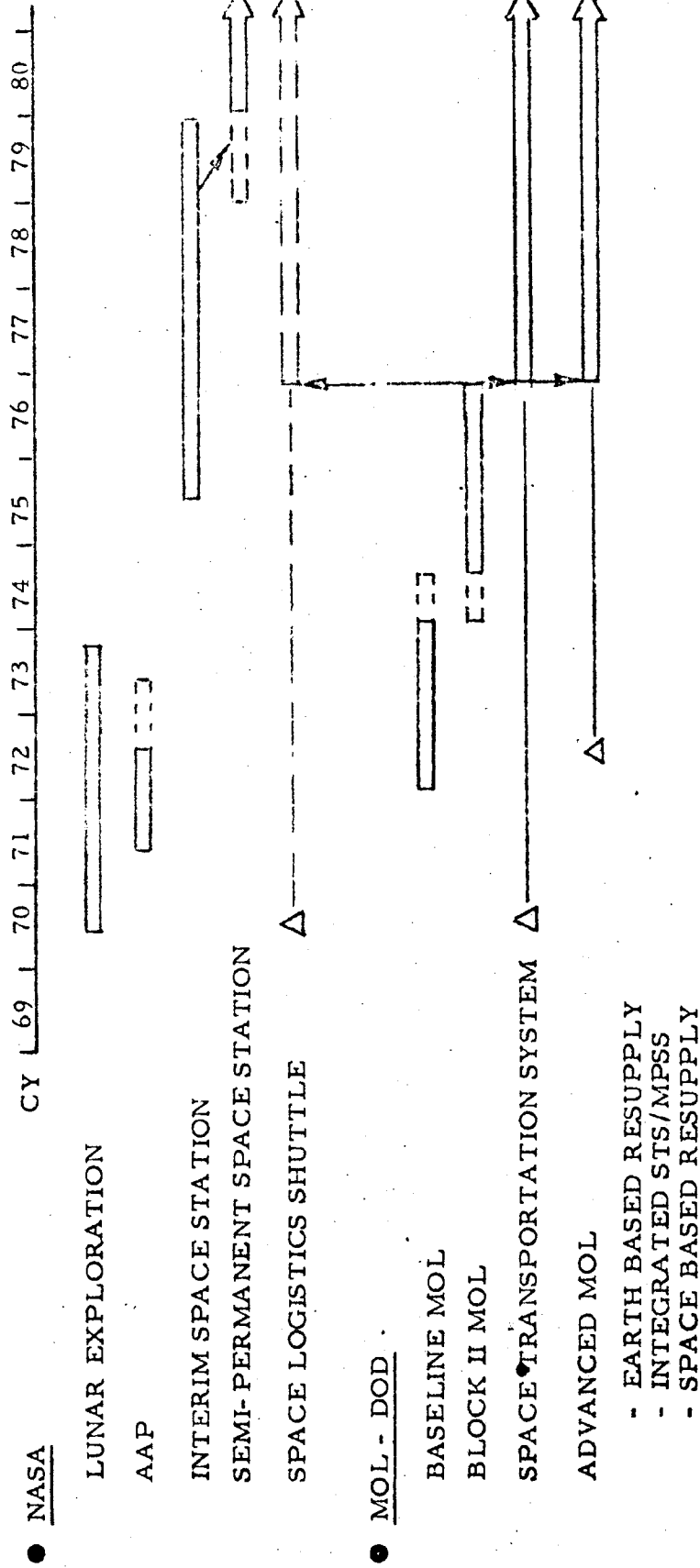

POTENTIAL MOL PROGRAM FLIGHT SYSTEM ALTERNATIVES





<u>VEHICLE SYSTEM</u>	<u>ON-ORBIT DURATION (DAYS)</u>	<u>CONFIGURATION</u>
EDMOL - EXTENDED DURATION MOL	45	
EDIL - EXTENDED DURATION INTEGRAL LAUNCH	60+	
RESUPPLY GRV - GEMINI RESUPPLY VEHICLE	1 YR @ 90 DAY R/R CYCLE	
RESUPPLY RRV - REUSEABLE RESUPPLY VEHICLE	1 YR @ 90 DAY R/R CYCLE	
IMS - INTEGRATED MISSION SYSTEM (1 1/2 STAGE OR FULLY REUSEABLE)	60	

FIGURE 13

~~SECRET~~/DORIAN

POTENTIAL MOL FLIGHT SYSTEM ALTERNATIVES SUMMARY
(10 YEARS OF OPERATIONS)

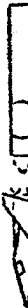

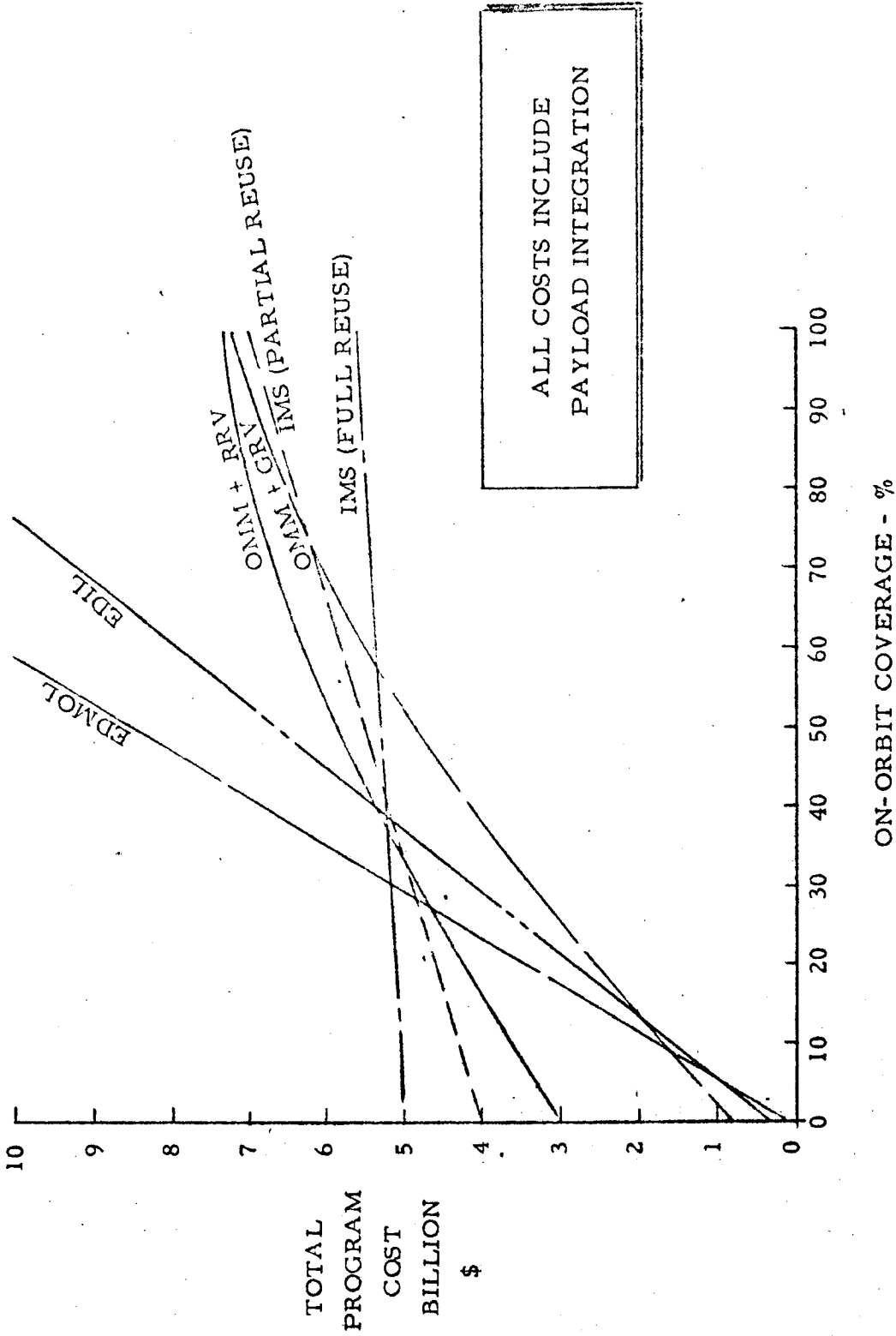
ALL COSTS INCLUDE
PAYLOAD INTEGRATION

~~SECRET~~/DORIAN

HANDLE VIA BYEMAN
CONTROL SYSTEM ONLY